



Solution Brief: QoS Billing

AMS – PACKETEER – HP Smart Internet Usage

Track, enforce, and bill Service Level Agreements

The QoS Billing solution will maximize service provider profitability and enable Service Providers to charge based on QoS information -- through the integration of application performance data from Packeteer devices with the HP SIU mediation data that is presented to the AMS billing software, Tapestry™. Tapestry provides different billing plans based on the service level actually delivered.

AMS brings billing expertise; Packeteer delivers network expertise, in particular, application behavior and performance on the network through bandwidth management and control; and HP SIU is a mediation system that collects and correlates the network information for presentation to a billing system.

Scenario

A Service Provider offers many services to their clients. Host applications might include videoconferences, VOIP, streaming audio or video, web browsing, email. The Service Provider wants to collect information on network usage and application performance in order to charge clients for services ordered and for the performance that was delivered for those services. By working together HP, Packeteer, and AMS provide a solution to track usage, quality of service,

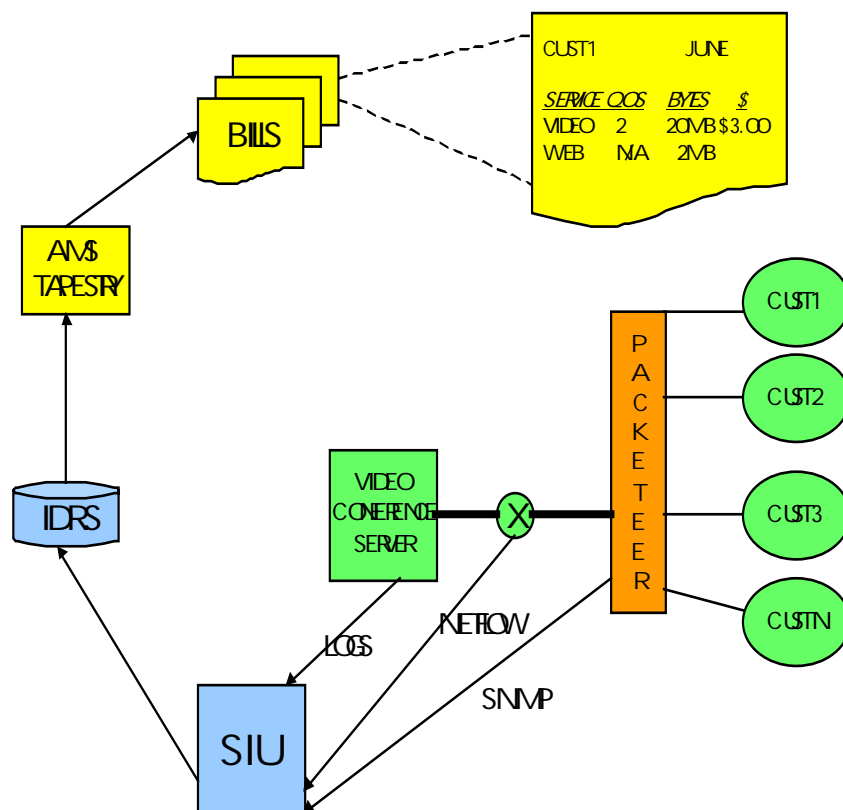

and offer different billing plans based on the service level actually delivered.

The successful integration of AMS's Tapestry, HP Smart Internet Usage (SIU), and Packeteer's PacketShaper and AppVantage products enable Service Providers for the first time to set rates for IP usage and create invoices for a variety of applications, including IP Voice, IP Fax, IP Videoconferencing and bandwidth management. This pioneering development ushers in a new era for the Internet, whereby Service Providers can realize significant new revenue, while customers benefit from increased freedom and flexibility in choosing – and paying for – the exact IP services ordered and delivered.

This solution supports the full array of rating and billing for usage-based IP services, including rating based on combinations of service type, service duration, data volume -- rating based on the number of packets or kilobytes actually delivered -- and QoS.

Tapestry can apply different QoS pricing rules--for example, pricing the delivered service in segments defined by QoS, or pricing the service using the lowest QoS observed.

Some of the benefits to service providers include:

- Proof positive that the service provided meets or exceeds the Service Level Agreement
- Convergent billing, e.g. able to offer discounts on ip services based on usage of telco services
- New revenues

Foundation of the Solution

HP Smart Internet Usage, gives service providers and network managers a comprehensive Internet usage-metering platform that scales to global proportions. SIU collects and correlates the network information for presentation to a billing system and other business support systems.

SIU features a distributed data collection platform that captures IP network activity and generates usage records analogous to the telephone industry's call detail records. It accesses usage information via collectors that operate on host computers located near metered network elements such as routers, switches, web servers, and gatekeepers. They are designed to normalize, aggregate, and correlate information from different network devices into IP usage records.

Packeteer's PacketShaper and AppVantage products provide a means to control and monitor the QoS delivered for an application(s). By analyzing network traffic to determine who is using what bandwidth and when, an administrator can assign policies that determine the priority given to various applications communicating through the PacketShaper.

The AMS Tapestry product provides convergent rating and billing. Services can be designed to allow cross-selling and discounts based on service usage in addition to QoS-sensitive billing plans.

AMS is an international business and information technology consulting firm – one of the 20 largest such firms worldwide. AMS is the premier provider of next generation enterprise business and technology solutions that dramatically improve business performance and create value for clients. AMS's suite of leading edge business and technology solutions, featuring eBusiness strategy, management and technology services make business reinvention possible in Internet time for large organizations.

When integrated, these three companies provide solutions to meet the proliferation of services and devices comprising the internet. To provide the solution your company requires, call the Smart Internet Hotline at (USA) 408-447-4815 or visit these websites: <http://www.hp.com/smartinternet> , <http://www.packeteer.com> , or <http://www.ams.com/tapestry> .

Tapestry is a trademark of American Management Systems Incorporated.



Hewlett-Packard
3000 Hanover Street
Palo Alto, CA 94304
(408) 447-4815
www.hp.com/smartinternet