

# hp instant recovery for the virtual array

## executive summary

HP Instant Recovery for the Virtual Array is an approach to data protection that utilizes logical, disk-based point-in-time copies (known as snapshots) of production data to enable data recovery in a matter of minutes in the event of unplanned downtime. This is in contrast to recovering data from a tape library, a process that could take hours or days depending upon the amount of data involved, and the number and speed of the tape drives.

This paper presents an HP Instant Recovery technical blueprint for building a disk-based data recovery solution for the HP StorageWorks Virtual Array family, and includes the solution design rules, sample bill of material, and example Instant Recovery solution from a logical and physical view. Specifications are supplied for the solution components and a discussion of scaling the Instant Recovery solution is also provided. The example Instant Recovery solution is for a SAN-attached configuration and assumes a va7400 disk array plus a ds2405 disk enclosure (total of 30 physical disk drives).

Using the HP Instant Recovery solutions described in this blueprint, customers can significantly reduce the time required to recover their data and thus avoid negatively affecting business productivity or revenue. Customers may also obtain cost savings by consolidating database servers into larger data stores due to the inherently smaller transaction logs and recovery window.

Figure 1 presents a logical view of an Instant Recovery solution configured in a SAN-attached configuration.

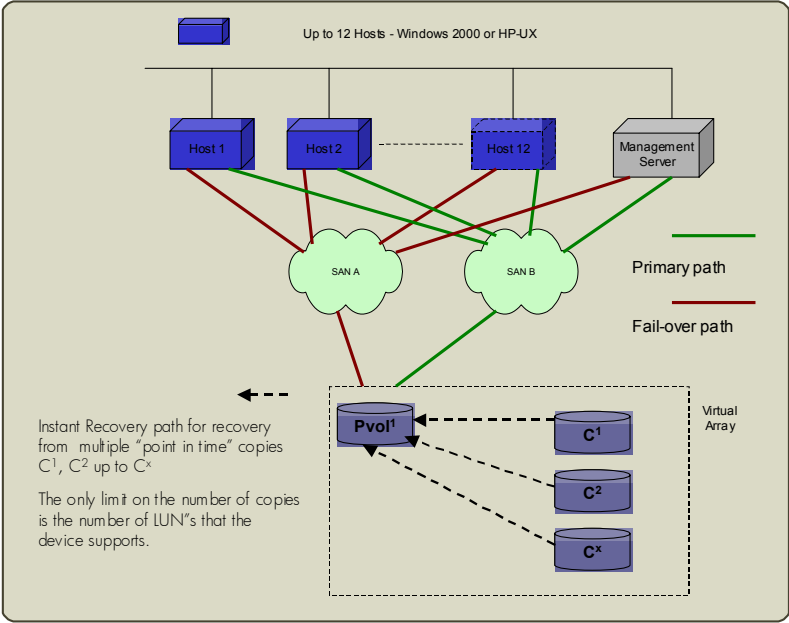

figure 1 - hp instant recovery solution logical view

## today's challenges in storage

Businesses today know that any downtime costs money, and the process of recovering data from tape devices can take hours or days to complete while business operations are put on hold. HP Instant Recovery enables customer to back data up to secondary disks and subsequently recover that data in minutes, rather than hours or days as with tape recovery. With this smaller recovery window, customers may consolidate multiple database servers into larger data stores. In addition, internal enterprise service providers can meet recovery service level agreements (SLAs) more easily and external service providers can add a premium level of recovery to their SLA portfolio

## why an hp instant recovery solution?

HP provides a fully tested and qualified, end-to-end solution built from industry-leading product components that are easy-to-use, and supported by one point of contact – HP. With a commitment to quality, and a service and support organization of over 30,000 professionals in 120 countries around the world, HP provides customers the peace of mind that comes from knowing their solution works right now – and will keep working for them into the future.

The engine behind the HP Instant Recovery solution is HP OpenView Storage Data Protector's replication and recovery management functionality. Data Protector has significant advantages over other technologies; for example:



- Easy scheduling of data replication tasks like create snapshots, and suspend/resume business applications
- Efficient management of multiple point-in-time copies with target volume pooling, point-in-time copy expiration and point-in-time copy volume recycling
- Optional integrated backup-to-tape HP OpenView Storage Data Protector licenses
- Ability to script "mount copy volume to backup server" command to support 3<sup>rd</sup> party backup applications from vendors like Veritas, Computer Associates and Legato
- Heterogeneous support across:
  - multiple business applications like Oracle, SAP, MS SQL and MS Exchange and application backup tools like SAP brbackup and Oracle RMAN
  - HP-UX and Windows operating systems as well as clustered environments

The HP StorageWorks Virtual Array and Business Copy software also bring significant advantages over other technologies:

- Using Business Copy VA, the customer may create more than more than 100 snapshots with the va7100 and more than 1,000 snapshots with the va7400 or va7410
- Multiple snapshots per parent volume are supported
- The Virtual Array family includes autoraid for maximum device ease of use and can support up to 128 servers in a SAN configuration

Every solution component is highly modular, easy-to-use and cost-effective to scale – from Data Protector's modular architecture and licensing to the Virtual Array's ability to non-disruptively add capacity.

## key components

<p>HP StorageWorks Virtual Array family</p> 	<ul style="list-style-type: none"> <li>• Pro-active self-monitoring and end-to-end checksums keep data intact across the entire data path</li> <li>• Fault tolerant, redundant architecture w/ no single point of failure</li> <li>• Multi-terabyte scalability</li> </ul>
<p>HP OpenView Storage Data Protector software</p> 	<ul style="list-style-type: none"> <li>• Innovative copy expiration and recycling method paired w/ advanced scheduling capabilities</li> <li>• Single, central management interface to manage replication, recovery and backup jobs and resources</li> <li>• Tightly integrated with OpenView management tools</li> </ul>
<p>HP StorageWorks Business Copy VA software</p> 	<ul style="list-style-type: none"> <li>• More than 100 snapshots w/ va7100 &amp; more than 1000 snapshots w/ va7400</li> <li>• Multiple snapshots per parent volume</li> <li>• Cluster support and easy-to-use GUI</li> </ul>

## hp instant recovery and hp StorageWorks tape solutions

HP Instant Recovery and hp StorageWorks tape solutions are both critical in designing a comprehensive data protection architecture. For example, in larger capacity environments, tape recovery is a complement to disk recovery – particularly when multiple point-in-time copies are required. In these cases, it will be more efficient to keep a smaller number of copy volumes on secondary disk for primary, more recent point-in-time recovery, and to rely on tape for secondary data recovery across less recent point-in-time copies.

In addition, a tape solution provides a separate device that protects against catastrophic disk device failure, and tape and magneto-optical media are more appropriate than disk for long-term data retention (archiving). Tape recovery will be also required for operating system environments not yet supported by HP Instant Recovery solutions.

<b>time to recover data*</b>			
	<b>250 GB's</b>	<b>400 GB's</b>	<b>600 GB's</b>
disk-based HP Instant Recovery	minutes	minutes	minutes
one LTO tape drive*	~5 hours	~8 hours	~12 hours
one AIT tape drive*	~6 hours	~10 hours	~15 hours
one Super DLT tape drive*	~7 hours	~11 hours	~17 hours
one DLT tape drive*	~13 hours	~20 hours	~30 hours
* tape drive time to recover reflects native transfers rates and does not include time to find and mount tape cartridges			

HP StorageWorks tape solutions offer a range of technologies to meet customer needs. For more information, please consult with your HP sales representative or channel partner, or review the HP Zero Downtime Backup and HP SAN backup technical blueprints.

## hp instant recovery and replication management

As previously stated, the data replication software - which enables secondary copies to be made from primary data volumes - used with HP Instant Recovery for the Virtual Array is Business Copy VA. However, unlike other similar solutions, hp instant recovery for the Virtual Array also incorporates OpenView Storage Data Protector to efficiently manage the point-in-time copies and processes that would otherwise be complex and difficult to administer. Below is a diagram describing how Data Protector manages the data replication processes within the HP Instant Recovery solution.

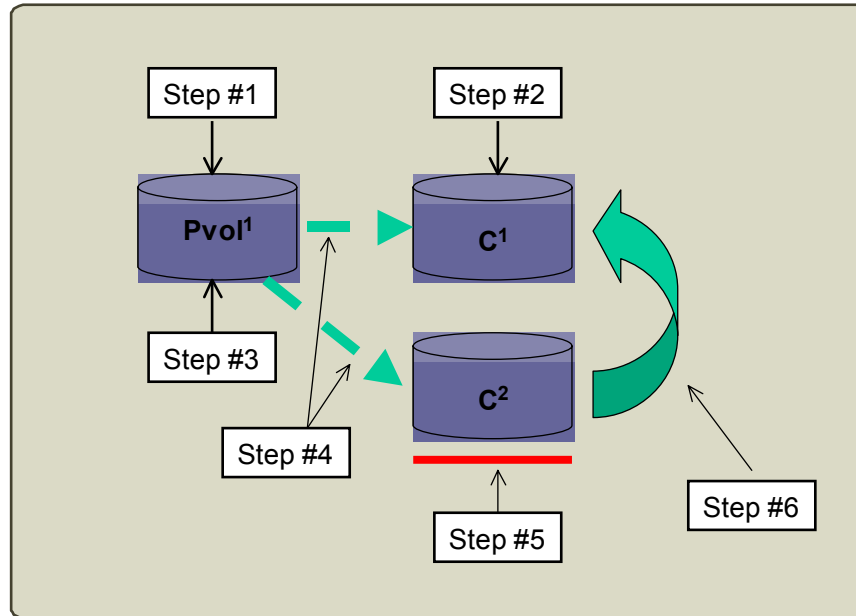

**figure 2- hp instant recovery replication management**

1. Stabilize the production data by suspending the business application and flushing the cache
2. Initiate a snapshot (C<sup>1</sup>) of the production data set
3. Resume business application
4. Ongoing snapshot copy on write operation
5. Retain the snapshot up to point of expiration
6. Recycle snapshot

This chain of operations may be extended to more than 100 snapshots with a va7100 device, and more than 1,000 snapshots with a va7400 or va7410 device.

## physical configuration of hp instant recovery

Included in this blueprint is a physical view of an Instant Recovery solution in a SAN configuration to facilitate cabling and physical design.

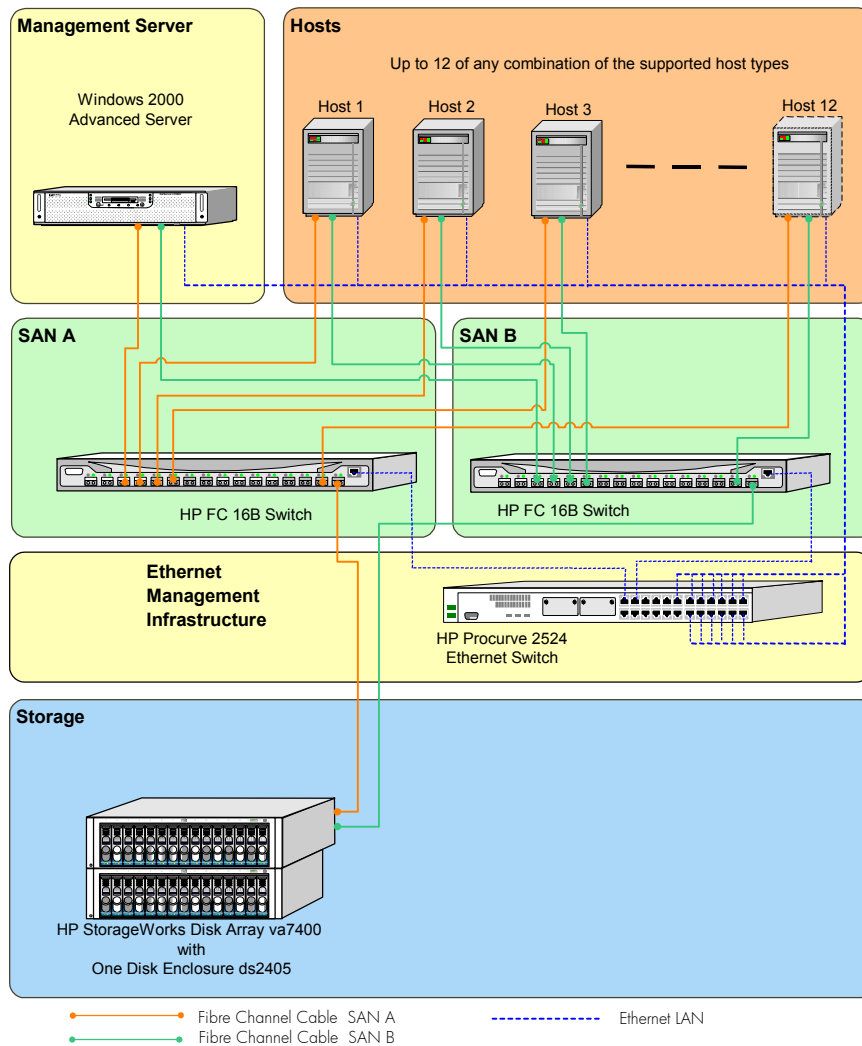

figure 3 - hp instant recovery solution physical view

The Ethernet switch provides important LAN connectivity for out-of-band SAN component management. For example, host-based agent software can be loaded from the management server using the Ethernet connection. See the Bill of Materials for specific component information.

The HP Instant Recovery solution is a SAN configuration that can be racked to minimize space at a customer's site. Pictured below is an HP Rack System/E33. If additional rack space is needed, an HP Rack System/E41 may be used. For example, space for fibre channel switches, additional ds2405's or tape libraries may be needed as the solution grows.

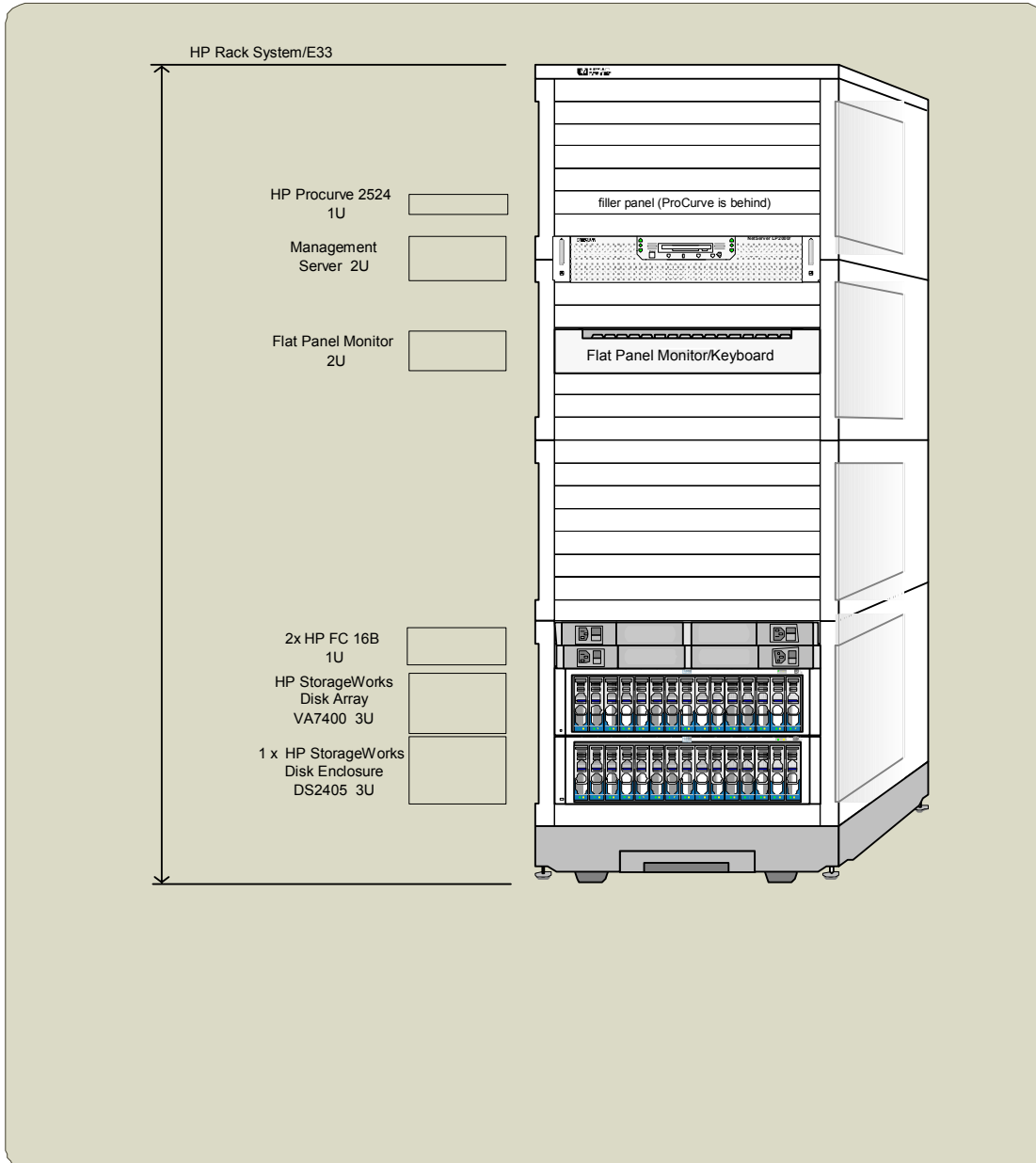

figure 4 - example hp instant recovery racked solution

## hp instant recovery for the virtual array: growing the solution

The example solution illustrated in this blueprint can be modified to meet specific customer needs. To provide this flexibility, design assumptions and rules are listed below.

### assumptions:

- va7400 and ds2405 are fully loaded (i.e. total of 30 drives – 15 each)
- Primary volumes will reside on smaller, faster 18 or 36 GB physical disk (recommended)
- Snapshot copy volumes will reside larger, less expensive 73 GB physical disks (recommended)
- Two snapshot copies will be maintained on an ongoing basis for recovery purposes
- Disk capacities for the primary volume and snapshot copy volume physical disks are calculated in autoraid mode
- Data replication occurs within the device using Business Copy VA

### rules:

- SAN solutions may accommodate up to 12 hosts of any of the supported types (see SAN supplement – “Supported Hosts” section) for one pair of HP FC 16B switches
- A total of 4 Fibre Channel switch ports are used for the management server and the va7400
- If using 18GB drives as the primary volume physical disks:
  - Usable capacity: ~240 GB’s for primary volumes
  - Required # of 73 GB drives to support secondary point-in-time copies: 10
- If using 36 GB drives as the primary volume physical disk:
  - Usable capacity: ~360 GB’s for primary volumes
  - Required # of 73 GB drives to support secondary point-in-time copies: 15
- If using 73 GB drives as the primary volume physical disk:
  - Usable capacity: ~480 GB’s for primary volumes
  - Required # of 73 GB drives to support secondary point-in-time copies: 20

### scaling options for the hp instant recovery solution

The example SAN solution provided in this technical blueprint can also scale over time to meet expanding customer requirements. If there is a need for more storage capacity, the customer should increase the size of the disk drives, add ds2405 enclosures and additional drives, or add additional storage arrays. Adding arrays may require additional Fibre Channel switches for additional connectivity and to maintain redundant paths. With additional disk capacity, more tape archive capacity will be needed as well. The example configuration may support more hosts and tape libraries by adding incremental meshed Fibre Channel switches.

For specific guidelines on selecting the appropriate components, please consult your HP sales representative or channel partner.

## hp instant recovery for the virtual array solution specifications

To ensure that the latest supported software, firmware and driver revisions are being used for Instant Recovery in SAN configurations, please check with your HP sales representative or channel partner.

Below are the specifications for a SAN-attached configuration.

supported hosts

### Supported Hosts and HBA's

	HP-UX	Windows
<b>OS Version</b>	11.0 & 11.11	2000
<b>HBA</b>	A5158A; A6684A; A6685A	QLogic 2200 F; Emulex LP 8000
<b>Application Integration</b>		
Oracle 8.1.x	yes	yes
Oracle 9i	yes	yes
SAP R/3	yes	yes
MS SQL Server 2000	n/a	yes
MS Exchange 2000	n/a	yes
File System	yes	yes
Raw logical volume	yes	no
Raw disk	yes	yes
<b>Application Backup Tool</b>		
Oracle RMAN	yes	yes
SAP brtools	yes	yes

interconnect

### SAN Fibre Channel Infrastructure

Features	fc 1GB/2GB switch 8B	fc 1GB/2GB switch 16B
Number of Ports	8	16
Per Port Line Speed	1.0625/2.125 gbps, full duplex	1.0625/2.125 gbps, full duplex

storage

### Disk Storage

Features	va7100	va7400	va7410
Array Raw Capacity	72 GB to 1.1 TB's	72 Gb to 7.7 TB's	72 GB to 7.7 TB's
External I/O Ports	Two 100 mbs	Two 200 mbs	Four 200mbs
Sustained Performance	90 mbps	170 mbps	330 mbps

management

**Management Server**

Features	Comments
HP NetServer LP2000r in the following configuration: <ul style="list-style-type: none"> <li>• 2 Processors (1.3 GHZ or better)</li> <li>• 1.5 GB or more of 133MHz ECC SDRAM</li> <li>• Redundant power supplies</li> </ul>	Order Windows 2000 Advanced Server
HP NetRAID 2M 64 MB Controller	
HP 18.2 GB 15K Ultra3 Wide SCSI-3 HS HDD	Order a minimum of 4, a maximum of 6

**Out-of-Band SAN Management – Ethernet Switch**

Features	HP Procurve Switch 2512	HP Procurve Switch 2524
Number of Ports	12	24
Speed	10/100 mbs	10/100 mbs

**Management/Backup Software Components**

Application	Host Agent	Description
HP OpenView Storage Area Manager	yes	Enables device monitoring, capacity planning, Fibre Channel performance evaluation, billing and LUN management
HP OpenView Storage Data Protector	yes	Manages replication and restore operations
HP StorageWorks Autopath	yes	Multipath fail-over and load balancing
HP StorageWorks Business Copy VA	no	Data replication
HP StorageWorks CommandView VA	no	Device management
HP StorageWorks Secure Manager VA	no	Provides device-based security to LUN's

services

**Life cycle**

	Description
<b>Invent</b>	Instant Recovery Design
<b>Build</b>	Business Copy implementation
	Data Protector implementation
	SAN implementation
<b>Run</b>	Business Continuity support
	SAN Environment support
<b>Evolve</b>	Performance/Capacity planning
	High Availability Storage Assessment

## bill of materials

The following is a listed bill of materials representing the hardware and software used in the example configuration in this blueprint.

### Bill of Materials

Management/Backup Server		
QTY	DESCRIPTION	COMMENTS
1	HP NetServer LP2000r in the following configuration: 2 Processors (1.3 GHz or better) 1.5 GB or more of 133MHz ECC SDRAM Redundant power supplies	Order Windows 2000 Advanced Server
1	HP NetRAID 2M 64 MB Controller	
4	HP 18.2 GB 15K Ultra3 Wide SCSI-3 HS HDD	Order a minimum of 4, a maximum of 6
1	HP Procurve 10/100 managed 24 port switch	
OpenView Software		
QTY	DESCRIPTION	COMMENTS
Variable	HP OpenView Storage Area Manager	SAM Suite includes Storage Node Manager, Builder, Accountant, Optimizer and Allocator
1	HP OpenView Storage Data Protector 5.0 Cell Manager single drive Windows Starter Pack ( LTU, Media and Manuals)	
Variable (* depends on TB of used disk space)	HP OpenView Storage Data Protector Zero Downtime Backup extension for HP Virtual Arrays	
Variable (* depends on TB of used disk space)	HP OpenView Storage Data Protector Instant Recovery Extension for HP Virtual Arrays	
StorageWorks Software		
QTY	DESCRIPTION	COMMENTS
variable	HP StorageWorks Business Copy VA	Includes media and LTU's
1	HP StorageWorks Command View VA	Includes media and LTU's
variable	HP StorageWorks Autopath VA	Includes media and LTU's
variable	HP StorageWorks Secure Manager VA	Includes media and LTU's
Virtual Array		
QTY	DESCRIPTION	COMMENTS
1	HP StorageWorks Disk Array va7400 dual controller, 256/512/1024 MB cache	Customer has choice of ordering the 256, 512 or 1024 MB cache configuration
1	HP StorageWorks ds2405 enclosure	
Variable (total disk drives may not exceed 30)	Enterprise class 18 GB 15k rpm FC hdd	Customer has choice of ordering a mix of 18GB, 36 GB or 73GB disk drives
	Enterprise class 36 GB 15k rpm FC hdd	
	Enterprise class 73 GB 10k rpm FC hdd	
Interconnect		
QTY	DESCRIPTION	COMMENTS
Variable	Optical SFP's	
2	HP FC switch 16B	
Host Hardware Components		
QTY	DESCRIPTION	COMMENTS
Variable	HP a5158a HBA	Two per HP-UX rp24xx (a-class), rp54xx (l class), rp74xx (n class), v-class and superdome hosts
Variable	HP a6685a HBA	Two per HP-UX k-class hosts
Variable	HP a6684a HBA	Two per HP-UX d and r class hosts
Variable	QLogic 2200F Fibre Channel or Emulex LP8000 HBA	Two per Windows 2000 server. Must be ordered from another vendor or reseller.

## **additional information**

### **business continuity solutions**

To get answers on further implementation questions, contact your HP sales representative or channel partner who will be able to consult regularly updated technical resources and provide additional guidance.

### **hp storage product components**

To get further information on individual storage product components, go to [www.hp.com/go/storage](http://www.hp.com/go/storage)

### **hp storage service components**

HP offers a complete life-cycle of storage support and consulting, for more information, go to [www.hp.com/hps/storage](http://www.hp.com/hps/storage)

### **hp storage integration**

HP also offers storage integration services, which provide a quick and trouble –free installation of your solution. For more information, go to [www.hp.com/hps/gds](http://www.hp.com/hps/gds)

All brand names are trademarks of their respective owners.

Technical information in this document is subject to change without notice.

© Copyright Hewlett-Packard Company 2002

07/02