

4.7.6—HP Surestore Disk Array XP512

Overview

This document provides an overview of the basic configurations as well as sales ordering information for the HP Surestore Disk Array XP512 enterprise storage solution.

The new unparalleled Hewlett-Packard Surestore Disk Array XP512 provides high-capacity, high-speed Enterprise Level storage with continuous data availability, heterogeneous systems support, and ease of serviceability, scalability, and connectivity. It can be attached to multiple open systems servers as well as to mainframes, meeting customer needs for a wide range of configurations up to a maximum raw capacity of 37 TB with 73-GB disk drives.

This exciting new storage solution consists of the following major components:

XP512 Hardware:

- DKC Controller Cabinet—contains control panel, service processor (SVP), cache modules, shared memory modules, crossbar switch, Client-Host Interface Processors (CHIPs) and Array Control Processors (ACPs).
- DKU—contains the disk drives. XP512 system may have one DKU cabinet up to a maximum of six DKU disk cabinets.

XP512 Software

- Continuous Access XP (includes RAID Manager)
- Business Copy XP (includes RAID Manager)
- Cache LUN XP
- Performance Manager XP
- Command View XP
- LUN Configuration XP
- Resource Manager XP
- Data Exchange XP
- Auto LUN XP

Support and Services:

- Hardware Support
- Software Support

Hardware

Hardware Components

Figure 4.7.6.1 shows the layout of the cabinets or frames comprising the subsystem. A minimum capacity system includes only one DKC and one DKU, while a maximum capacity system includes one DKC and six DKUs. The central frame or DKC contains the Array Control Processors (ACPs), redundant power, cache memory, shared memory, and Client Host Interface Processors (CHIPs). The DKUs contain the disk drives and redundant power.

Figure 4.7.6.1 XP512 Cabinet/Frame Configuration

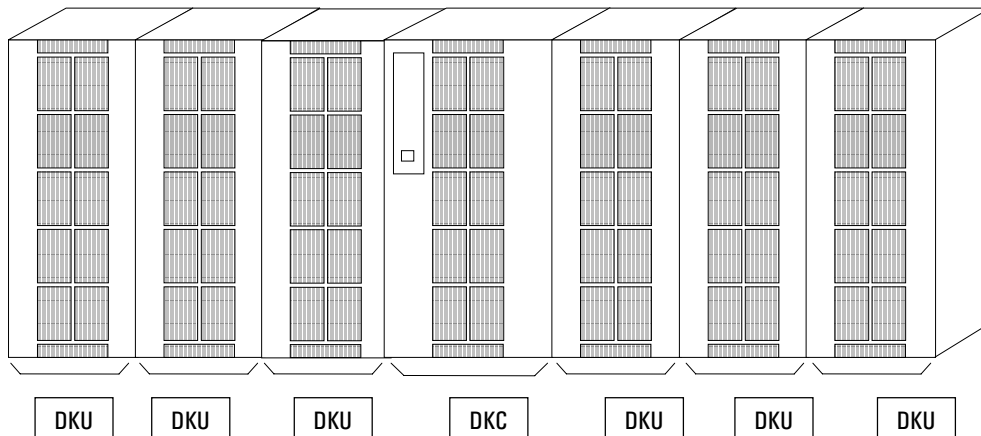
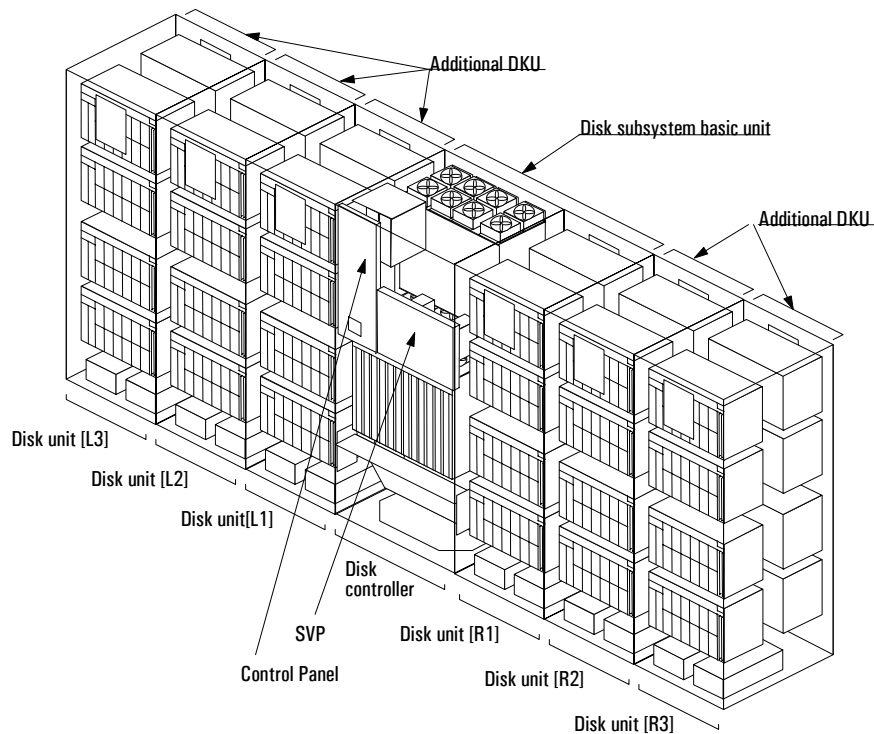

Figure 4.7.6.2 show a more detailed view of the Surestore Disk Array XP512.

Figure 4.7.6.2 XP512 Detailed View



Controller Frame (DKC)

The Controller Frame (DKC) features the following:

- Fully redundant components, with no single points of failure
- Dynamically-duplexed cache with battery backup—cache is expandable from 2 GB up to 32 GB total capacity in 2-GB increments.
- Crossbar switch—fast, efficient, switching with direct point-to-point connections at 6.4 GB/sec.
- Shared memory—stores command and control data so that the entire amount of cache memory is available for quick access to user data. Shared memory is expandable from 512 MB to 1.2 GB in 256-MB increments.
- Power redundancy—single-phase or three-phase 50 or 60 Hz.

Figure 4.7.6.3 XP512 Architecture Overview

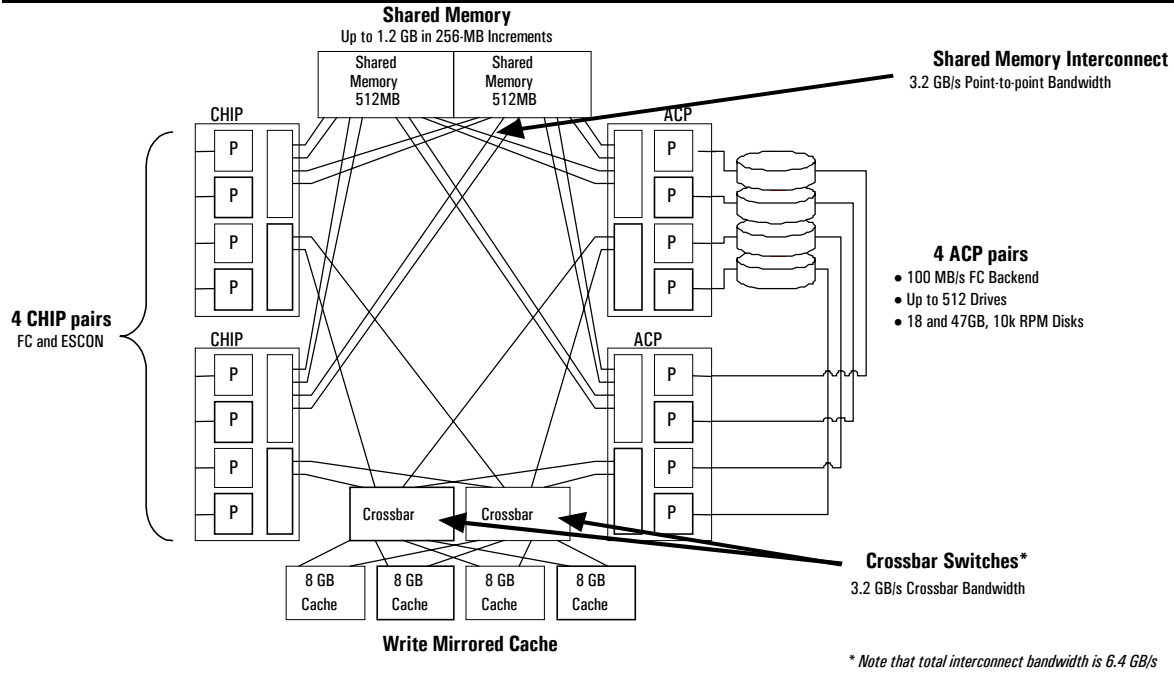

Client Host Interface Processors (CHIPS)

CHIPS are available in pairs with a minimum of one pair up to a maximum of four pairs of fully mixable CHIPS per XP512 system. Here are the available CHIP pairs:

- 8-port Fibre Channel adapter pair
- 4-port and 8-port ExSA—Extended serial interface (ESCON compatible) adapter pair.

Notes:

1. *ESCON CHIP pairs must be used to interconnect two arrays in conjunction with Continuous Access XP for remote mirroring solutions.*
2. *The XP512 does not offer native SCSI CHIP pairs. For SCSI connectivity, the A5814A router must be used to convert SCSI host protocol to FC. This router is supported in non-HA configurations for HP-UX, MPE/iX, and NT, point-to-point connections only.*

Figure 4.7.6.4

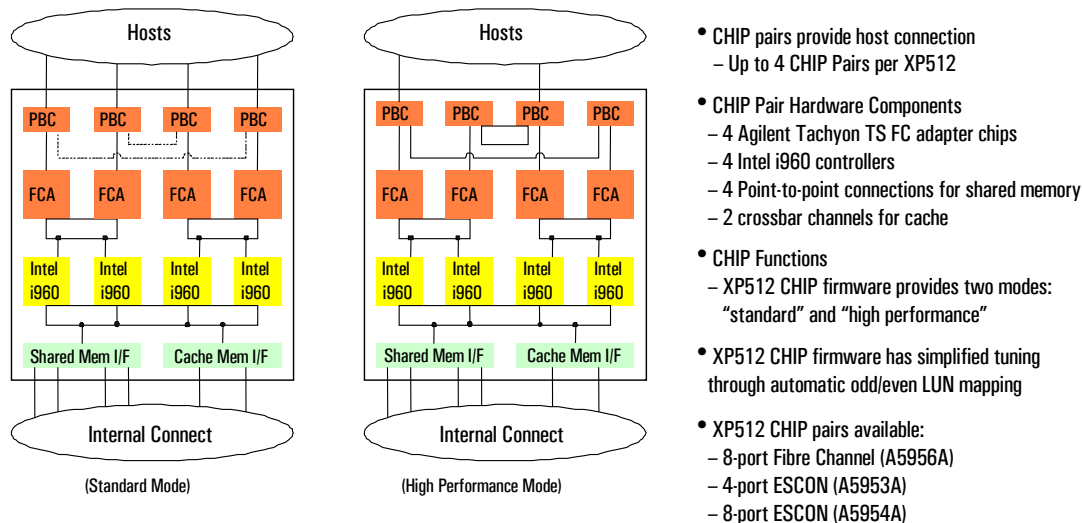

Array Control Processors (ACPs)

Array Control Processors (ACPs) are configured in pairs for redundancy, up to a maximum of four pairs per system. The exact number of ACP pairs chosen depends on the number and frame location of the disk drive configuration. The quantity may also be influenced by workload performance characteristics. Each ACP pair controls a single disk domain. Mixed RAID levels are now supported on an ACP pair.

Figure 4.7.6.5

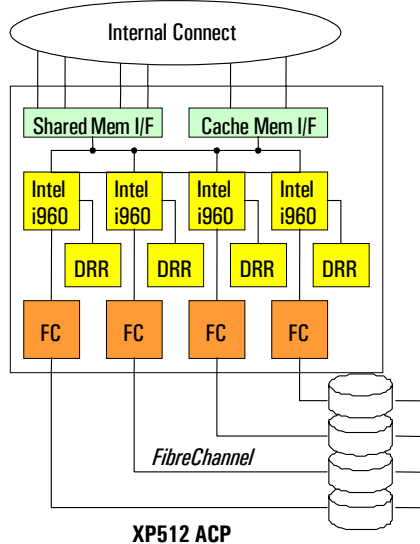

- Connect the disk drives to the DKC
 - Up to 4 ACP Pairs per XP512 Array
 - Up to 128 100 MB/s FibreChannel disks
 - 8 FC-AL loops per ACP pair (4 per card)
 - Uses Agilent Tachyon -TL FibreChannel Interface chips
- ACP Hardware Components:
 - 4 Intel i960 controllers
 - 4 Data Recovery and Restore (DRR) Parity Generator chips (RAID5 parity)
 - 4 Point-to-point connections for Shared Memory
 - 2 Crossbar channels for Cache
- ACP Functions:
 - Read/Write Control to Disks
 - Read Miss/Write Staging from Cache
 - Media Protection (disk scrubbing, Dynamic Spares, Dynamic Data rebuild)
 - Mirroring Control (RAID 0/1)
 - Hardware RAID5 parity generation
- HP Product Number: A5964A

Dynamic sparing disk details:

- Minimum of one recommended for each capacity disk drive used in the array
- Maximum of 16 spares are configurable (8 “dedicated”, 8 that require trade-off with data)
- Any spare of “like capacity” can backup any other disk of the same capacity anywhere in the array
- Dynamic sparing/rebuild causes no disruption in host I/O processing
- Dynamic sparing is controlled by CAP firmware

Cache Memory

The XP512 base product comes standard with 2 GB of cache and is expandable up to 32 GB in increments of 2 GB. All cache is backed up by a fully redundant 48-hour battery (two 48-hour batteries for a total of 96 hours of backup).

Dynamic Duplex Cache is an area of cache set aside for “write” data. All data written to the cache is written to the Dynamic Duplex Cache and is duplicated across power boundaries. The write cache percentage may be modified manually or can be adjusted dynamically by the XP512.

2-GB XP512 Cache Increments (A5962A)

Note: Cache memory protection during powerfail—for HP-UX systems with a UPS, cache memory can be written to disk upon powerfail. Refer to the following URL for more details:

http://esbu.boi.hp.com/esbuatc/hw_prods/xp256/xp256.htm

Figure 4.7.6.6

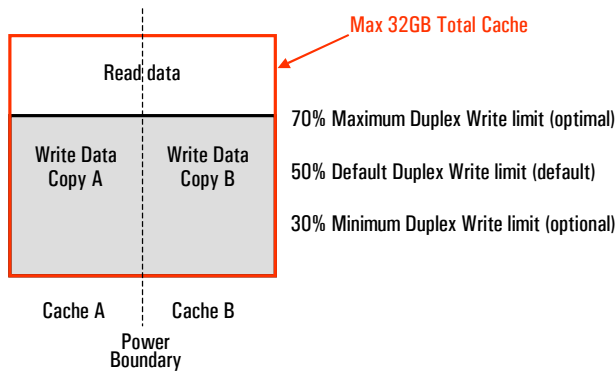

Cache Expansion Platform Board (A5960A)

This board is required if more than 16 GB of cache is configured.

For all light workloads including OLTP, this board is not required.

This board is however, recommended for heavy sequential workloads >500 MB/s (data warehousing, decision support, supercomputer computations). For these workloads, a minimum cache size of 8 GB populated across all four cache boards is recommended.

Shared Memory—256-MB Shared Memory Module (A5963A)

Shared memory is independent of the cache memory and is used to store tables, side files, and other information overhead, thus freeing up the cache memory for user data. It is also used to store system configuration mapping of system components, LUN maps, cache pointers, hit rates, and RAID levels.

The base XP512 configuration contains 512 MB of shared memory and is expandable to a maximum of 1.28 GB of shared memory in increments of 256 MB.

Table 4.7.6.1 is intended as a guideline for configuration of cache and shared memory for the XP512. It assumes Open8 or Open9 emulation.

Table 4.7.6.1 XP512 Cache and Shared Memory Configuration Table

Recommended Cache Size (GB)	Usable Capacity	Number of Array Groups								Recommended Shared Memory Size (MB)
		RAID-1				RAID-5				
		18 GB	47 GB	73 GB	Raw Capacity	18 GB	47 GB	73 GB	Raw Capacity	
2	Up to 500 GB	1-16	1-6	1-4	Up to 1 TB	1-11	1-4	1-3	Up to 750 GB	512
4	500-800 GB	17-27	7-10	5-6	1-1.7 TB	12-17	5-6	4	750 GB-1.1 TB	512
6	800 GB-1.3 TB	28-38	11-15	7-10	1.7-2.8 TB	18-25	7-9	5-6	1.2-1.7 TB	512
8	1.3-7.4 TB	39-126	16-82	11-53	2.8-15.4 TB	26-126	10-53	7-35	1.7-10 TB	768
10	7.4 TB-max.	—	83-126	54-126	15.4-36.7 TB	—	54-126	36-126	10-36.7 TB	1,024

Note: Applications requiring > 500 MB/s throughput should configure the cache expander option and at least 8 GB of cache storage.

Note: Applications that make heavy use of the cache should use 1.5 times that amount of cache recommended above. This will increase the shared memory requirement and should be done in consultation with a suitable trained Back Office engineer (who has complete tables).

Note: Very large Oracle instances may require additional cache to absorb a synchronization fully without stalling. This is a very advanced topic in which HP Consulting or equivalent expertise should be engaged. Alternatively, install the recommended cache and then use Performance Manager to measure array performance in the real application adding cache until Performance Manager shows it is not the limited factor. Again, increasing cache size may require increased shared memory; a suitable trained person MUST be engaged.

XP512 System Layout (DKC and DKUs)

Each system can accommodate a minimum of one up to a maximum of six DKU frames. The maximum configuration contains 126 disk groups. R1 and L1 can accommodate 23 disk groups with 1 group for spares. R2 and L2 can accommodate 24 array groups. R3 and L3 can accommodate 16 array groups.

Figure 4.7.6.7 XP512 Array Group Configuration Diagram

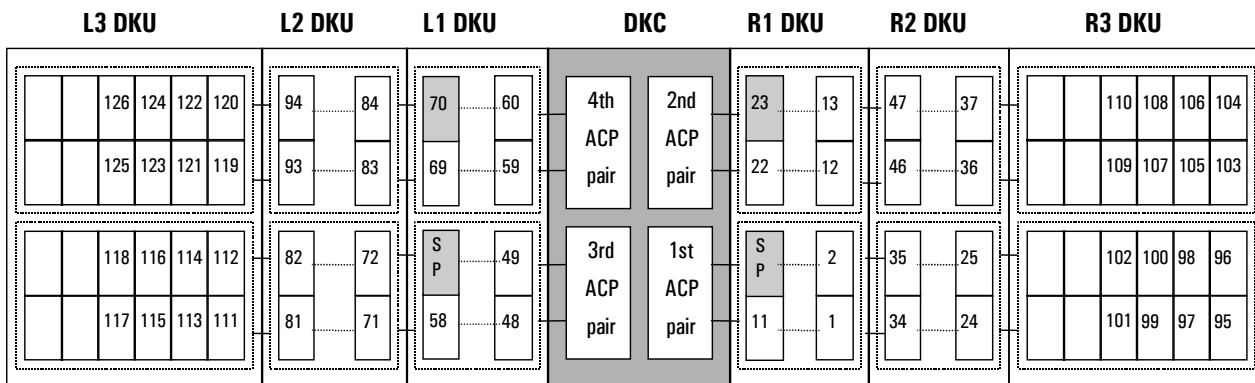

The array group numbers do not represent loading sequences.

Disk Drives

Table 4.7.6.2 summarizes the specifications of the disk drives supported by the HP Surestore Disk Array XP512. All disks are dual ported with fibre channel interface.

Table 4.7.6.2 XP512 Disk Drive Specifications

Disk Drives Specs	18 GB	47 GB	73 GB
Raw capacity	18.4 GB	47.2 GB	72.9 GB
Disk diameter	3 inches	3 inches	3 inches
Rotation speed	10,025 rpm	10,025 rpm	10,025 rpm
Mean latency time	3.0 ms	3.0 ms	3.0 ms
Mean seek time	5.2-6.0 ms	5.7-6.5 ms	5.7-6.5 ms
Internal data transfer rate	30-46 MB/sec	30-46 MB/sec	30-46 MB/sec
Interface type	Dual-Ported Fibre Channel	Dual-Ported Fibre Channel	Dual-Ported Fibre Channel
Group of four disks	A5966A	A5967A	A5968A

Disk Drive Emulation Types

Table 4.7.6.3 XP512 Disk Drive Emulation Types

	18 GB			47 GB		
	Open3	Open8	Open9	Open3	Open8	Open9
RAID 5	22	7	7	57	19	19
RAID 0/1	14	5	4	38	12	12

Factory Defaults

- 1) RAID 5 default factory configuration.
- 2) "Open8" emulation for RAID 0/1 provides 5 LDEVs versus 4 LDEVs with "Open9".
- 3) Array Group Factory Defaults with RAID 5:
 - 18-GB Open3: 22 LDEV per array group
 - 47-GB Open9: 19 LDEV per array group

Figure 4.7.6.8 XP512 DKU Disk Cabinet Capacities and Interconnect Cables

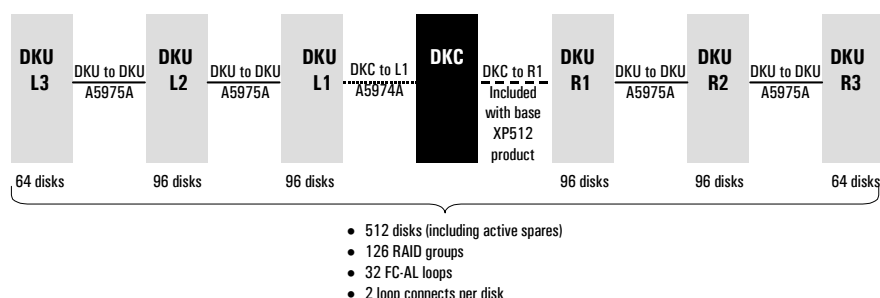

AC Power Options

Single-phase and three-phase AC power options are available for the XP512. Power options must be specified for the DKC and DKU. This table summarizes the product number options related to power.

Cannot order mixed power options within a single XP512 system.

	Three-phase AC		Single-phase AC	
	60 Hz	50 Hz	60 Hz	50 Hz
DKC	A5951A	A5951A	A5951A Option 001	A5951A Option 002
DKU	A5965A Option 001	A5965A Option 002	A5965A Option 003	A5965A Option 004

XP512 Uninterruptible Power Supply (UPS) Recommendations

See the following URL for a white paper describing UPS recommendations for the XP512:
http://esbu.boi.hp.com/esbuatc/hw_prods/xp256/xp256.htm

XP512 Configuration Rules

- One RAID level per ACP (RAID 1/0 or 5)
- Up to 126, 4-disk array groups (18-, 47-, 73-GB)
- 1- to 4-channel host interface processor
 - 8-port Fibre Channel
 - 4- or 8-channel ESCON
- 1-16 dynamic spares
 - 126 array groups available (with 8 spares)
 - 124 array groups (with 16 spares)
- Cache expansion
 - Required for >16-GB cache
 - Very large configuration only!
- Cache—2 GB standard in base configuration expandable in 2-TB increments to 32 GB
- Shared memory—512-MB standard in base configuration, expandable in 256-GB increments to 1.2 GB

Disk Drive Intermix Rules

- Cannot mix emulation types within an array group
- Cannot mix disk drive sizes within an array group
- Cannot mix RAID levels on a single ACP pair

XP512 LDEV Creation

Determine usable disk and performance requirements for the XP512 array, then:

- Select physical disk size: 18-, 47-, 73-GB
- Select RAID level: RAID 0/1 or 5
- Assign emulation types: Open3, 8, 9
- Assign LDEVs to open volumes
- Assign LUNs to LDEVs

Software

Software Descriptions

The following are brief descriptions of the software products available with the XP512:

Command View XP—B9357A

Command View XP is a web-based management platform for the HP Surestore Disk Array XP family of products. Command View features a simple, web-browser based interface that provides quick access for you to view the status and health of your XP resources, configures and manages LUNs, analyzes I/O performance, migrates volumes and establishes LUN security.

Included with Command View XP is the windows-based application formerly known as Remote Control XP.

The XP512 must have the following firmware versions:

- DKC Revision: 01-10-97-00/2
- SVP Revision: 01-10-36/00

The following applications are integrated into the Command View XP interface: LUN Configuration Manager XP, Cache LUN XP and Secure Manager XP. All other applications are managed via Remote Control.

Command View XP installs a web server and Java applets and requires a dedicated PC for the web server and the management console. In the interim, this PC will also act as the Remote Control console that connects to both the private and public LANs. A single PC can manage sixteen (16) arrays.

Hewlett-Packard recommends the following HP Visualize Workstation as the dedicated PC. However, customers have the option of purchasing their own PC solution.

- A5015A—HP Visualize P Class Personal Workstation
- A6012A—PIII Enhanced 600 MHz CPU
- A5028A—128-MB DIMM for P and X class systems (Qty 2)
- A1270A—13-GB IDE disk
- A5988A—48x CD ROM drive
- A1290A—Elsa Synergy II AGP graphics card
- Microsoft Windows NT 4.0 SP5 (Workstation or Server)

Note: Only Microsoft Windows NT 4.0 SP5 is supported on the management station (Remote Control PC).

Included with Command View XP is a 60-day trial evaluation of the four supported applications. The 60-day trial evaluation is initialized via a special software key. A Software Enablement Certificate is provided in the Command View box. The customer needs to fill this Enablement Certificate completely, as the information will be used by HP to assign software keys. The 60-day evaluation will only start once the temporary software keys are entered into the SVP. The customer has the ability to evaluate these software solutions for only one 60-day timeframe. The evaluation timeframe cannot be extended. At the end of the 60-day evaluation, management through these software packages will cease. A 10-day key is available to HP personnel for emergency situations only. This “emergency” key can be used only once.

Customers can evaluate solutions individually or all at once. Customers can also purchase individually or purchase all of the solutions at once.

Figure 4.7.6.9 Command View XP Management Architecture

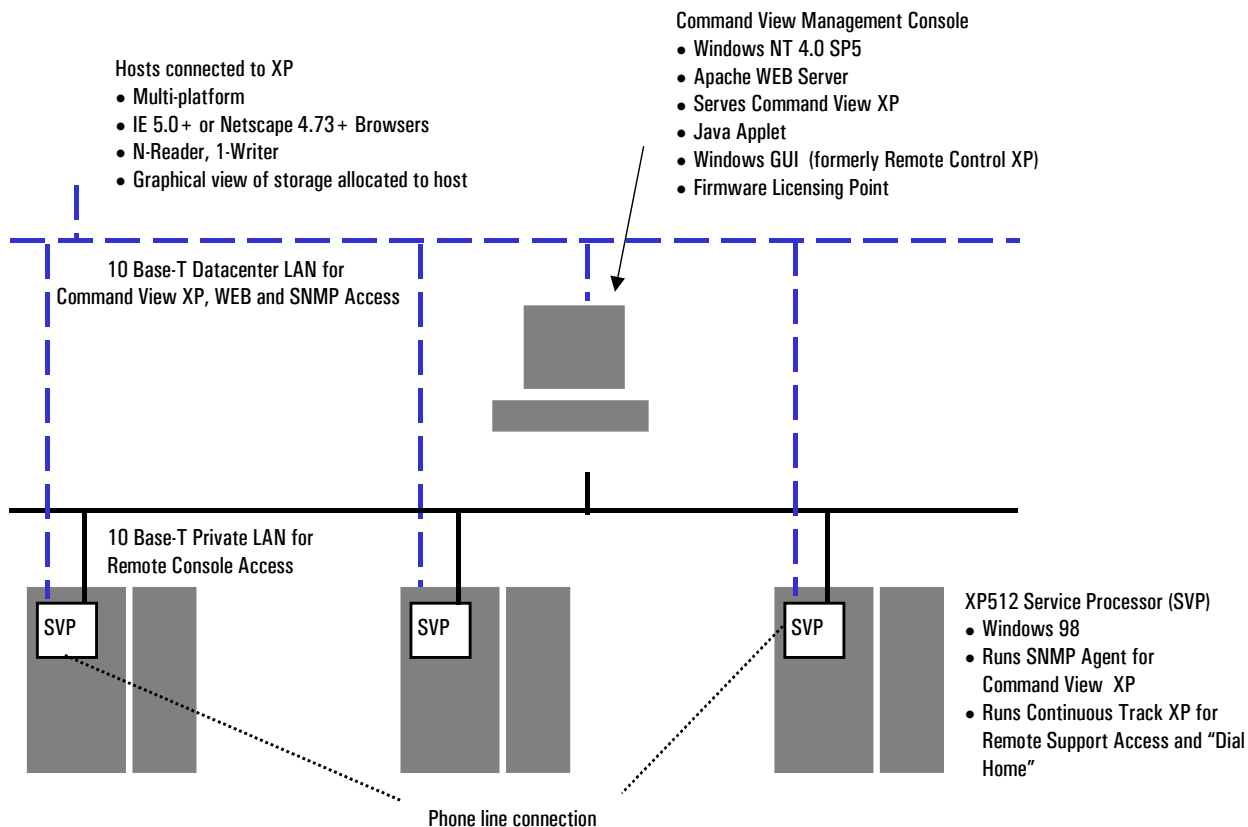

Continuous Access XP—Media: B9320A, Licenses: B9321A, B9322A, B9323A

Provides synchronous copy mode-only remote data mirroring, allowing data to be copied from an array at one site to an array at a remote site (Remote mirroring solutions requiring distancing of greater than 3 Km require ESCON Extenders or ESCON to WAN Converters. See page 17 for more information). This allows for implementation of a disaster recovery plan. RAID Manager is included with purchase of Continuous Access XP. RAID Manager provides OS-specific, host based software initiated from a server via a command line interface that allows full user control of Continuous Access XP (and Business Copy XP) from the host server. RAID Manager also provides functionality for synchronized operation with cache and OS, etc. If launching from a host using scripts, a consulting engagement may be recommended. RAID Manager must be installed on each host acting as failover controller/arbitrator. The customer can control this using Command View XP software. **ESCON CHIP pairs, RAID Manager XP (included), and Command View XP required.**

***Example:** Scripting can be used to implement Metro Cluster ServiceGuard fail-over. The control lines are LAN-based and the data lines are ESCON-based. If a customer wants to manage from the host server using RAID Manager, and it is scripted at both the local and remote sites, then one RAID Manager will talk to a daemon at the copy of RAID Manager at other site through the LAN connect. In the event of a failure the remote site is notified, the mirrors are broken and the remote site takes over.*

RAID Manager must be installed on each host acting as failover controller/arbitrator. The customer can control this Command View XP software. The Following OS are supported by RAID Manager:

- HP-UX
- MPE/iX (delivered as a patch)
- Windows NT/2000
- AIX
- Solaris
- Tru64
- DYNIX
- LINUX

Important: For Host systems employing Veritas Journal File System (JFS), at least version 3.3 must be used for proper operation of Fence level parameters.

Business Copy XP—Media: B9330A, Licenses: B9331A, B9332A, B9333A

Provides local multi-mirroring, by creating up to 9 data copies, for a total of 10 images, including the original. This product is useful for allowing non-production activities such as backup and batch processes to take place on the copies. Control can be established RAID Manager and Command View XP software. Business Copy is also used for Remote Mirroring Solutions in conjunction with Continuous Access XP and XP Extension. RAID Manager is included with purchase of Business Copy XP. See Continuous Access XP for a description of RAID Manager functionality. **RAID Manager XP (included) and Command View XP required.**

Cache LUN XP—Media: B9345A, Licenses: B9346A, B9347A, B9348A

Allows a specified area within a LUN to be stored in cache. Accessing data from cache on reads makes the access time much faster. With Cache LUN XP you can designate all or part of a LUN for storage in cache. Customers can also control/ configure this product themselves if Command View XP Software is purchased. **Command View XP and LUN Configuration Manager XP required.**

Performance Manager XP—B7909A

Provides performance monitoring for the disk array. Runs on the Remote Control XP platform (Windows 95,98, or NT) to monitor and adjust disk array performance. A customer or service consultant can examine the workload and reallocate the cache read /write ratio according to user needs, i.e. optimize batch at nights, and OLTP days. This may not be run on the same PC at the same time as other Remote Control XP applications. If a customer wants to use this tool regularly, it is best to run a separate Remote Control XP on a separate PC. **Separate PC recommended. This can run on same PC as Command View (Remote Control).**

LUN Configuration Manager XP—Media: B9335A, Licenses: B9336A, B9337A, B9338A

Contains the following three applications and can be executed by the customer on the Command View XP management station:

- LUN Manager—Allows the capability to create a LUN and assign it to a port.
- LUSE—Allows up to 36 LUNs to be combined into a larger one.
- CVS—For instance, allows creation of smaller size LUNs for data that had been locked in cache.

Command View XP required.

Resource Manager XP—B9358A

Allows the disk array to be connected to mainframe MVS systems and to Open Systems platforms. It allows the data on the array to be shared among MVS systems and Open Systems servers. **ESCON CHIP pairs and Command View XP required.**

Data Exchange XP for XP512 (Not supported on MPE/iX)

- Data Exchange for HP-UX—B9359A
- Data Exchange for Windows NT—B9360A
- Data Exchange for Sun Solaris—B9361A
- Data Exchange for AIX—B9362A

Enables high-speed bi-directional data exchange between MVS systems via ESCON links and Open Systems via SCSI. Provides file translations as required through a file conversion utility. **ESCON CHIP pairs, Resource Manager XP, and Command View XP required.**

Auto Path XP (not supported on MPE/iX see High Availability FailOver/iX)

Enables I/O path failover and load balancing control for dual path connection to servers. Allows for multiple paths (8 maximum) to be configured to a LUN and provides for automatic, application transparent fail over in the event of path failure. Allows for dynamic, multi-path load balancing to a LUN to prevent any single path from becoming overloaded with I/O operations.

Software Licensing

See XP 512 Configuration Guide

Table 4.7.6.4 summarizes the licensing structure for capacity-licensed XP Software titles.

Licenses for Capacity-licensed Software titles are based on total array raw disk capacity of the array. Example: configuration with 35 each 15-GB and 75 each 47-GB storage disks would represent $(35 \times 18) + (75 \times 46.9) = 4,147.5$ GB (~4.2 TB) raw disk capacity.

Table 4.7.6.4

Software Title	Product Number	License Terms
Continuous Access XP	Media: B9320A #001 (XP256) B9320A #002 (XP512) Licenses: 1-TB - B9321A 5-TB - B9322A 10-TB - B9322A	License-to-use on one array based on total array raw disk capacity
Continuous Access XP Extension	Media: B9325A #001 (XP256) B9325A #002 (XP512) Licenses: 1-TB - B9326A 5-TB - B9327A 10-TB - B9328A	License-to-use on one array based on total array raw disk capacity
Business Copy XP	Media: B9330A #001 (XP256) B9330A #002 (XP512) Licenses: 1-TB - B9331A 5-TB - B9332A 10-TB - B9333A	License-to-use on one array based on total array raw disk capacity
Cache LUN XP	Media: B9345A #001 (XP256) B9345A #002 (XP512) Licenses: 1-TB - B9346A 5-TB - B9347A 10-TB - B9348A	License-to-use on one array based on total array raw disk capacity
LUN Configuration Manager XP	Media: B9335A #001 (XP256) B9335A #002 (XP512) Licenses: 1-TB - B9336A 5-TB - B9337A 10-TB - B9338A	License-to-use on one array based on total array raw disk capacity
Auto LUN XP	Media: B9340A #001 (XP256) B9340A #002 (XP512) Licenses: 1-TB - B9341A 5-TB - B9342A 10-TB - B9343A	License-to-use on one array based on total array raw disk capacity

Other Licensed Software Titles

Table 4.7.6.5 summarizes the licensing structure for other XP Software titles.

Table 4.7.6.5

Software Title	Product Number	License Terms
Performance Manager XP	B7909A	One PC client (remote console) XP256/XP512 common LTU
Command View XP	B9357A #001: new XP256 system #002: new XP512 system (except as described in #004) #003: Upgrade for existing XP256 (with Remote Control) #004: Remote Control for new XP512 added to an existing XP256/Command View environment	One PC Client (remote console)
Resource Manager XP	B9358A #001: new XP256 system #002: new XP512 system	One array connected to MVS systems

Server Connectivity

SCSI Host Connections

The XP512 has no native SCSI CHIP pairs. Therefore, any SCSI host connections require the A5814A SCSI to FC router product. This router will take the host server SCSI connection and convert it to fiber channel. It is supported only on HP-UX, MPE/iX, and NT 4.0 systems in non-HA environments. Only one point-to-point SCSI connection is supported from a host server to the XP512, and only one fibre cable can be connected directly to the XP512 (ONE-TO-ONE only). No switch or hub connections are supported.

Table 4.7.6.6 SCSI to FC Bridge Support for XP512 via A5814A SCSI-FC Router

Supported Connections	Supported OS	Supported Servers	Non-HA Support	HA Software Support ¹		
				MD/UX	MC/SG	SG-OPS
Direct Connect	MPE/iX 6.0, 6.5, 7.0	E-Class (9x8), K-Class (9x9KS, T-Class (9x9), N-Class, A-Class	Yes	No	No	No
	HP-UX 10.20	A-, D-, K-, R-Class	Yes	No	No	No
	HP-UX 11.0	A-, D-, K-, r-, V-, N-, L-Class	Yes	No	No	No
	W2K	HP and non-HP W2K servers	Yes	No support planned		
	NT EE4.0, SP6+	HP and non-HP NT servers	Yes	No support planned		

¹ MD/UX = MirrorDisk UX; MC/SG = MC/ServiceGuard; SG-OPS = ServiceGuard OPS Edition

Host Bus Adapter Support for SCSI to FC Router (A5814A)

Table 4.7.6.7 shows the support for the XP512 using the FC array adapter A5956A (private NL). Port Host Mode should be set to 08. No hubs or switches are supported.

Table 4.7.6.7 HBA Support for the Surestore Disk Array XP512

Host Bus Adapter	Host Port Type	Patch/Driver (minimum level)	Supported Servers	Connection Supported			
				Direct Connect	SW 2400/2800	F16	L10/S10 Hubs
HP-UX 11.0							
A4800A (PCI)	FWD SCSI	PHKL-17258	V- (2200/2250/2500/2600), L-, N-Class	To router only.	N/A	N/A	N/A
A5159A (PCI)	FWD SCSI	PHKL-17258	L-, N-Class				
A4107A (HSC)	FWD SCSI	PHKL-17258	R-, D-, A-Class				
A2969A (HSC)	FWD SCSI	PHKL-17258	K-Class				
HP-UX 10.20							
A4107A (HSC)	FWD SCSI	PHKL-17468	R-, D-, A-Class	To router only			
A2969A (HSC)	FWD SCSI	PHKL-174658	K-Class				

Table 4.7.6.7 HBA Support for the Surestore Disk Array XP512 (continued)

Host Bus Adapter	Host Port Type	Patch/Driver (minimum level)	Supported Servers	Connection Supported			
				Direct Connect	SW 2400/ 2800	F16	L10/S10 Hubs
NT4.0 SP6+ and W2K							
A5252B (PCI) (Adaptec AHA- 2944UW)	FWD SCSI	NT Bundle	HP and non- HP Servers	To router only	N/A	N/A	N/A
MPE/iX 6.0, 6.5							
28696A (HP-PB) rev 3728	FWD SCSI	6.0 – Power Patch 2 6.5 – Power Patch LX84	E-Class (9x8), K-Class (9x9KS), T-Class (9x9)	To router only	N/A	N/A	N/A
MPE/iX 7.0 Express 1							
A4800A, A5159A	Ultra2 SCSI	7.0 – Express 1	N-Class, A-Class	To router only	N/A	N/A	N/A

Hardware and Software Services

See “XP512 Configuration Guide”.

HP Surestore Disk Array XP512 Configuration Template

Table 4.7.6.8 provides a step by step guide for specifying the configuration of an XP512.

Table 4.7.6.8 Configuration Steps for the XP512

Steps	Comments
1. Select the raw disk capacity desired	
<ul style="list-style-type: none"> • Determine the quantity and type of disks desired (18-, 47- or 73-GB) • Calculate the number of 4-disk array groups 	
2. Select the control frame components.	<ul style="list-style-type: none"> • One DKC contains 1 ACP pair. • Choose 3-phase or 1-phase AC power • For 1-phase, choose 60 Hz or 50 Hz • 1-GB cache, 512-MB shared memory base configuration • Redundant power supply needed for greater than two CHIP pairs
<ul style="list-style-type: none"> • Host interface (quantity and type) • Additional cache • Additional cache board • Additional shared memory • Additional array control processor pairs • Redundant power supply for CHIP pairs 3 to 4 	<ul style="list-style-type: none"> • SCSI, Fiber Channel, ExSA (ESCON compatible) • Cache can be configured up to 32 GB (see table) • An additional cache board is needed for > 16-GB cache memory • For SCSI, must use router A5814A to convert SCSI to FC
3. Select disk array frames and the array groups	<ul style="list-style-type: none"> • Choose 3-phase or 1-phase AC power • Choose 50-Hertz or 60-Hertz operation for the desired AC power • Follow the minimum/maximum array group requirements for disk frames R1, R2, L1, and L2, as required.
4. Select host interface cables	
5. Select software and licenses	
6. Select upgrade products including spare disk drives	
7. Select hardware and software services and support features	
8. Import a configuration generated by Watson or SBW	

Simplified Manual Procedures for XP512 Configurations

Cautions and Warnings

These procedures make many general assumptions about the most common XP512 configurations and do not cover mixed drives sizes, mixed RAID-0/1 or RAID-5 configurations or many other special cases (which are supported). Please contact the appropriate GSS team (1-447-7070) for a more detailed analysis or review. Some of the selections in these procedures are not orderable from the factory. The factory will configure and ship based on the following rules:

- All Subsystems from the factory will be configured with RAID 5.
- LUN configurations will follow a "Fixed Standard" where:
 - All 47-GB Array Groups installed will be configured Open9: 19 LDEVs per group.
 - All 18-GB Array Groups installed will be configured Open3: 22 LDEVs per group

Intent

To provide rules of thumb and describe the basic configuration process as an educational tool, as well as provide enough information for the manual selection of required components as a starting point for a valid configuration (first order approximation). These procedures do not cover spares analysis and selection or storage requirements for the Business Copy or other additional software.

General Steps

The following general steps are required to determine the basic configuration parameters:

1. DKC
2. Disk Storage and Structure
3. Cash and Shared Memory Sizes
4. Front-end Interfaces
5. Software, Installation and Support
6. Console Requirements

DKC

A. Select DKC AC Power

3-phase and 1-phase AC Power is available for the XP512. Choose the appropriate product number for the desired phase option and mode (60-Hz or 50-Hz).

Disk Storage and Structure

B. Select Disk Size and RAID Level

Three drive sizes are currently supported with either RAID level. Choose the drive size and RAID level that most closely matches your existing drives and protection needs:

	RAID-1/0	RAID-5
18 GB	yes	yes
47 GB	yes	yes
73 GB	Yes	yes

RESULTS:
Disk Size: _____
RAID Level: _____



C. Select Emulation Type (Open3, Open8, or Open9)

For 47-GB Array Groups, Open9 emulation allows for the most efficient use of raw disk capacity. Its larger LDEV size (7.347 GB) also allows optimum scalability into larger configurations. Open3 is used for 18-GB drives.

RESULT:
Open: _____

D. Compute Number of Array Groups Required

Consult the online Usable Disk Capacity Spreadsheet to compute the number of Array Groups required for the desired amount of useable storage.

RESULT:
Number of Array Groups: _____

E. Select ACP Pairs and DKU Cabinet Types

The following loading sequence is the recommended default and will provide the highest level of performance. Choose product numbers for the desired AC Power (3-phase or 1-phase) and mode (50-Hz or 60-Hz).

RESULTS:
ACP Pairs: _____
Cabinet Type: _____

Cache and Shared Memory Sizes

Use the Table shown earlier in this guide to determine the recommended minimum cache size. Simply use the useable storage capacity to select the minimum cache size. If the Cache LUN XP, LUN Configuration Manager XP, and Continuous Access XP Extension are being proposed, the cache memory requirements should be increased.

RESULTS:
Cache Size: _____
Shared Memory Size: _____

Front-end Interfaces

Open systems host connections are Fibre Channel based. Follow the appropriate procedures below:

- SCSI Based Connections—Need to use the router product A5814A that converts SCSI on the host side to FC on the XP512 side. See configurations that are supported.
- Fibre Channel Based Connections—One to four Client-Host Interface Processor pairs (CHIPS) can be specified, each pair providing 8 FC ports. Select the correct number based on the number of hosts and their connectivity and performance needs. Order the additional power supply for CHIP pairs 3 to 4.

Software, Installation and Support

See the configuration guide chapters for these topics.

Console Requirements

Command View XP requires an NT workstation or server. (See Command View XP section for details.)