



# Product End-of-Life Disassembly Instructions

**Product Category:** Personal Computers

**Marketing Name / Model**

[List multiple models if applicable.]

Name / Model #1: HP Compaq dc7700 Slim Tower (ST) Business PC

Name / Model #2

Name / Model #3

Name / Model #4

Name / Model #5

**Purpose:** The document is intended for use by end-of-life recyclers or treatment facilities. It provides the basic instructions for the disassembly of HP products to remove components and materials requiring selective treatment, as defined by EU directive 2002/96/EC, Waste Electrical and Electronic Equipment (WEEE).

## 1.0 Items Requiring Selective Treatment

1.1 Items listed below are classified as requiring selective treatment.

1.2 Enter the quantity of items contained within the product which require selective treatment in the right column, as applicable.

Item Description	Notes	Quantity of items included in product
Printed Circuit Boards (PCB) or Printed Circuit Assemblies (PCA)	With a surface greater than 10 sq cm	2 or 3 (main sys bd, 1 or 2 power supply)
Batteries	All types including standard alkaline and lithium coin or button style batteries	1
Mercury-containing components	For example, mercury in lamps, display backlights, scanner lamps, switches, batteries	
Liquid Crystal Displays (LCD) with a surface greater than 100 sq cm	Includes background illuminated displays with gas discharge lamps	
Cathode Ray Tubes (CRT)		
Capacitors / condensers (Containing PCB/PCT)		
Electrolytic Capacitors / Condensers measuring greater than 2.5 cm in diameter or height		5, 2, or 7 depending on power supply
External electrical cables and cords		
Gas Discharge Lamps		
Plastics containing Brominated Flame Retardants		
Components and parts containing toner and ink, including liquids, semi-liquids (gel/paste) and toner	Include the cartridges, print heads, tubes, vent chambers, and service stations.	

Components and waste containing asbestos		
Components, parts and materials containing refractory ceramic fibers		
Components, parts and materials containing radioactive substances		

## 2.0 Tools Required

List the type and size of the tools that would typically be used to disassemble the product to a point where components and materials requiring selective treatment can be removed.

Tool Description	Tool Size (if applicable)
Description #1 Phillips screwdriver	
Description #2 Dikes	
Description #3 Torx screwdriver	T-15
Description #4	
Description #5	

## 3.0 Product Disassembly Process

3.1 List the basic steps that should typically be followed to remove components and materials requiring selective treatment:

1. To remove the access panel (see Figure 1):
  - a. Press the buttons on the left and right sides of the computer (1).
  - b. Slide the computer cover toward the front of the computer until it stops (2), then lift it up and off the chassis..
2. To remove the power supply:
  - a. Remove the security clip (see Figure 2).
  - b. Rotate the drive cage up and disconnect the power cables from all of the drives.
  - c. Disconnect the power cables from the system board.
  - d. Release the power supply cable from the cable retaining clips on the bottom of the chassis under the drive cage.
  - e. Disconnect the hood sensor from the system board and remove the sensor from the power supply if required.
  - f. Rotate the power supply to its full upright position (1), and then lift the power supply straight up and out of the chassis (2) (see Figure 3).
3. To remove the system board:
  - a. Remove the fan shroud from the chassis (see Figure 4).
  - b. Remove the chassis fan from the chassis (see Figure 5).
  - c. Rotate the drive cage to its full upright position.
  - d. Remove the security clip (if necessary) and rotate the power supply to its full upright position.
  - e. Remove the long mounting screw that secures the system board tray to the chassis (see Figure 6).
  - f. Slide the system board tray assembly towards the front of the chassis, about 6 mm (1/4 inch) and lift the system board up and out of the chassis (see Figure 7).
4. To remove the battery:
 

Locate the battery and battery holder on the system board. Depending on the type of battery holder on the system board, complete the following instructions to remove the battery

TYPE 1 BATTERY HOLDER (see Figure 8):  
Lift the battery out of the holder.

TYPE 2 BATTERY HOLDER (see Figure 9):  
To release the battery from its holder, squeeze the metal clamp that extends above one edge of the battery. When the battery pops up, lift it out.

TYPE 3 BATTERY HOLDER (see Figure 10):  
Pull back on the clip that holds the battery in place, and then remove the battery
5. To remove the power supply PCA:
 

HP uses three different power supplies from two different vendors in these computers. Use the following steps to determine which power supply you have and its required disassembly procedures.

POWER SUPPLY 1

  - a. Remove three screws from the top the power supply (see Figure 11).
  - b. Remove the one screw from the back of the power supply (see Figure 11).
  - c. Remove the one screw from the front of the power supply (see Figure 12).

- d. Cut the plastic tie that secures the wires to the cover (see Figure 12).
- e. Remove the top cover from the power supply by sliding it toward the back of the power supply to disengage the clips that secure the cover to the power supply.
- f. Remove the side cover by rotating the cover to disengage the tabs that secure the side cover into the power supply chassis, and then sliding the cover toward the front of the power supply.
- g. Cut the wires from the PCA.
- h. Remove the three screws that secure the PCA to the power supply chassis (see Figure 13).
- i. Remove the power supply PCA from the power supply.
- j. Cut the five capacitors as shown in Figure 14.

#### POWER SUPPLY 2

- a. Remove one screw from the back the power supply (see Figure 15).
- b. Remove the three screws from the top of the power supply (see Figure 16).
- c. Remove the one screw from the front of the power supply (see Figure 16).
- d. Cut the plastic tie that secures the wires to the cover (see Figure 16).
- e. Remove the top cover from the power supply by sliding it toward the back of the power supply to disengage the clips that secure the cover to the power supply.
- f. Remove the side cover by rotating the cover to disengage the tabs that secure the side cover into the power supply chassis, and then sliding the cover toward the front of the power supply.
- g. Cut the wires from the PCA.
- h. Remove the three screws that secure the PCA to the power supply chassis (see Figure 17).
- i. Remove the power supply PCA from the power supply.
- j. Cut the small PCA from the large power supply PCA (see Figure 18).
- k. Cut the two capacitors as shown in Figure 18.

#### POWER SUPPLY 3

- a. Remove six screws from the top the power supply (see Figure 19).
- b. Remove the one screw from the front of the power supply (see Figure 19).
- c. Remove the two screws from the back of the power supply (see Figure 20).
- d. Cut the plastic tie that secures the wires to the cover (see Figure 20).
- e. Remove the top cover from the power supply by sliding it toward the back of the power supply to disengage the clips that secure the cover to the power supply.
- f. Remove the side cover by rotating the cover to disengage the tabs that secure the side cover into the power supply chassis, and then sliding the cover toward the front of the power supply.
- g. Cut the wires from the PCA.
- h. Remove the four screws that secure the PCA to the power supply chassis (see Figure 21).
- i. Remove the PCA from the power supply.
- j. Cut the seven capacitors as shown in Figure 22.

3.2 Optional Graphic. If the disassembly process is complex, insert a graphic illustration below to identify the items contained in the product that require selective treatment (with descriptions and arrows identifying locations).

FIGURE 1: Removing the access panel.



FIGURE 2: Removing the security clip

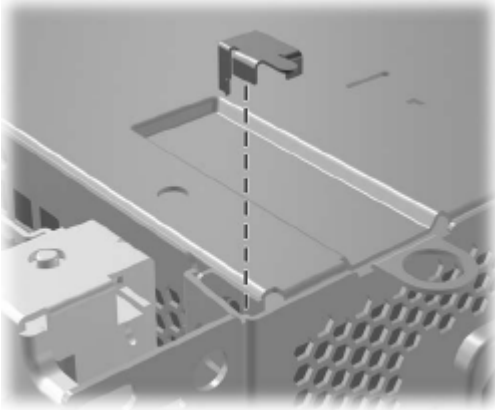

FIGURE 3: Removing the power supply

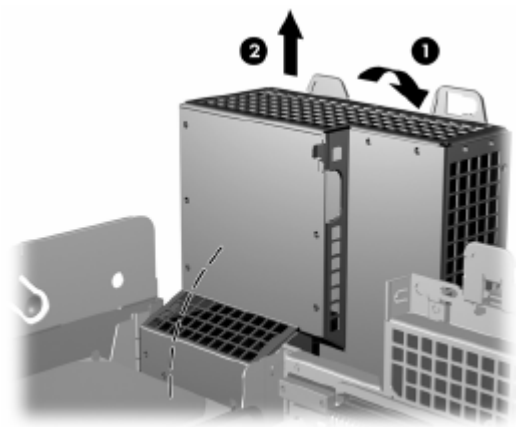

FIGURE 4: Removing the fan shroud

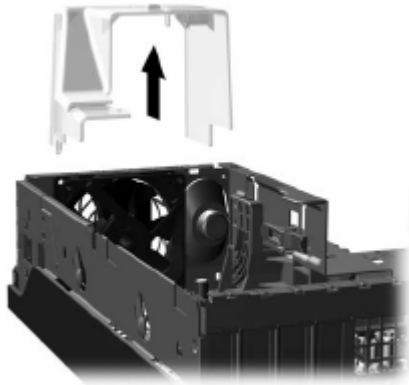

FIGURE 5: Removing the chassis fan

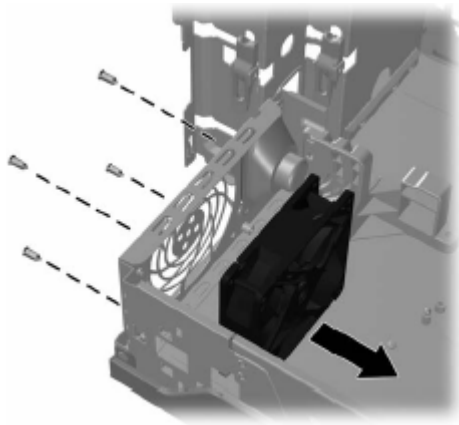

FIGURE 6: Removing the system board screw

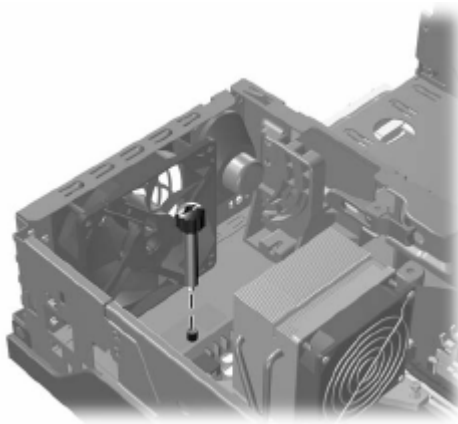

FIGURE 7: Removing the system board

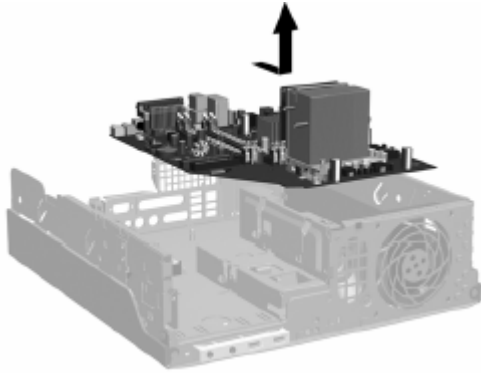

FIGURE 8: Type 1 battery holder

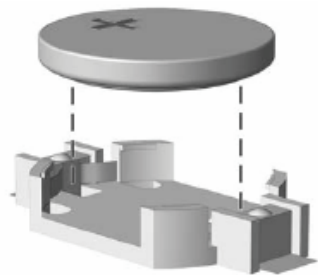

FIGURE 9: Type 2 battery holder

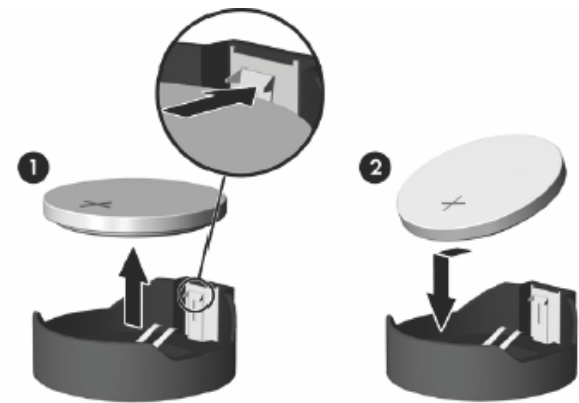

FIGURE 10: Type 3 battery holder:

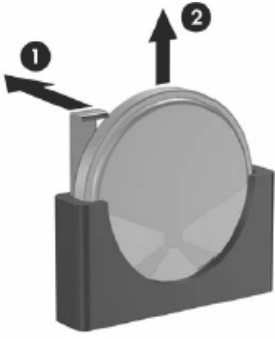

FIGURE 11: Power supply 1 – Cover screw locations

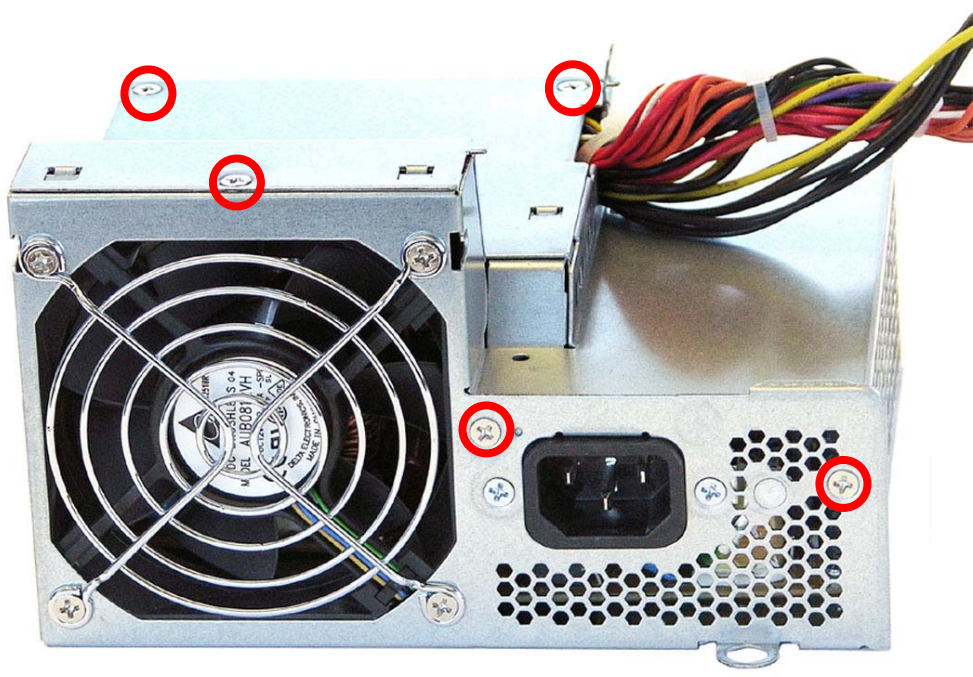

FIGURE 12: Power supply 1 – Cover screw and plastic tie locations

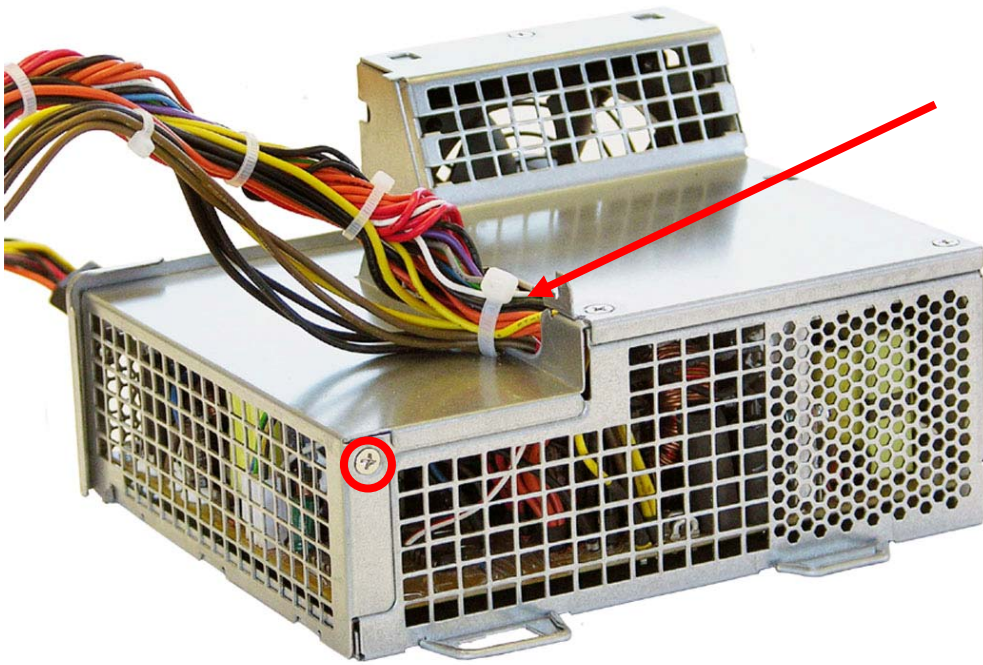

FIGURE 13: Power supply 1 – PCA screw locations



FIGURE 14: Power supply 1 – Capacitors to cut (5)

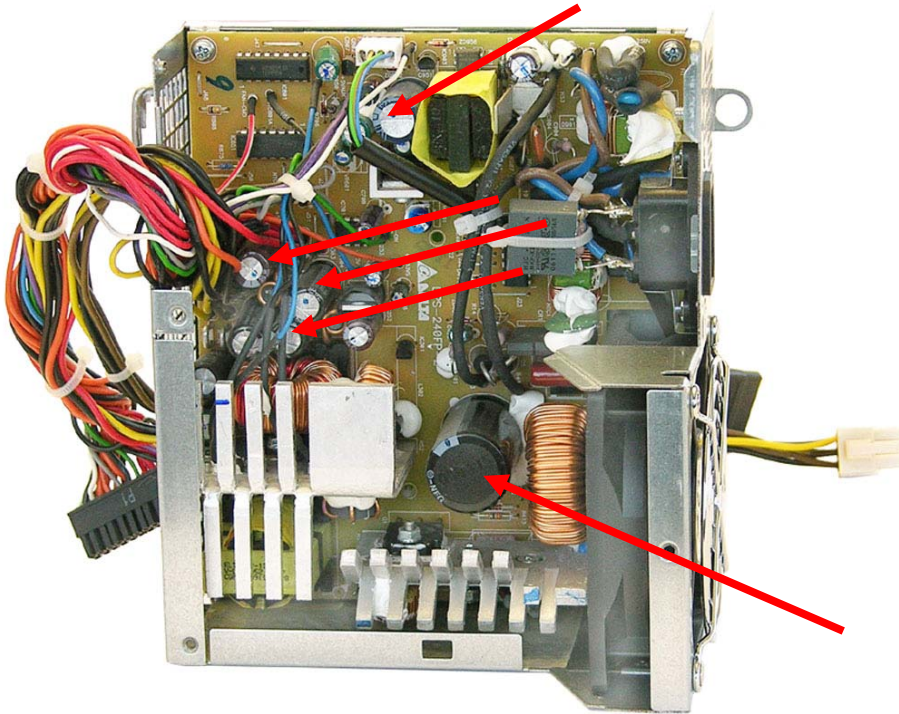

FIGURE 15: Power supply 2 – Cover screw location



FIGURE 16: Power supply 2 – Cover screw and plastic tie locations

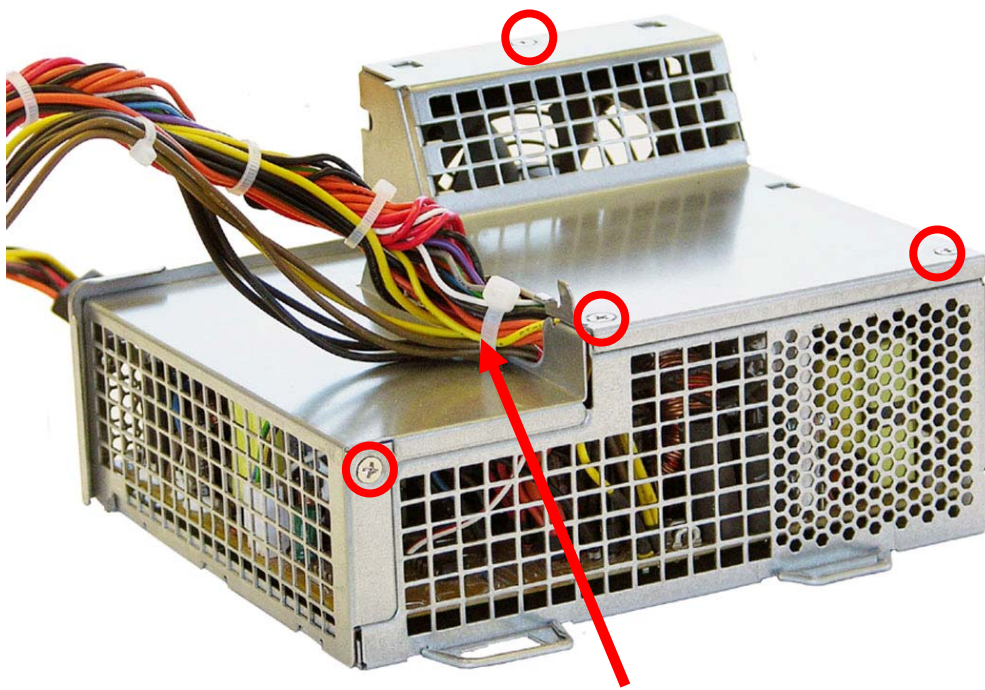

FIGURE 17: Power supply 2 – PCA screw locations

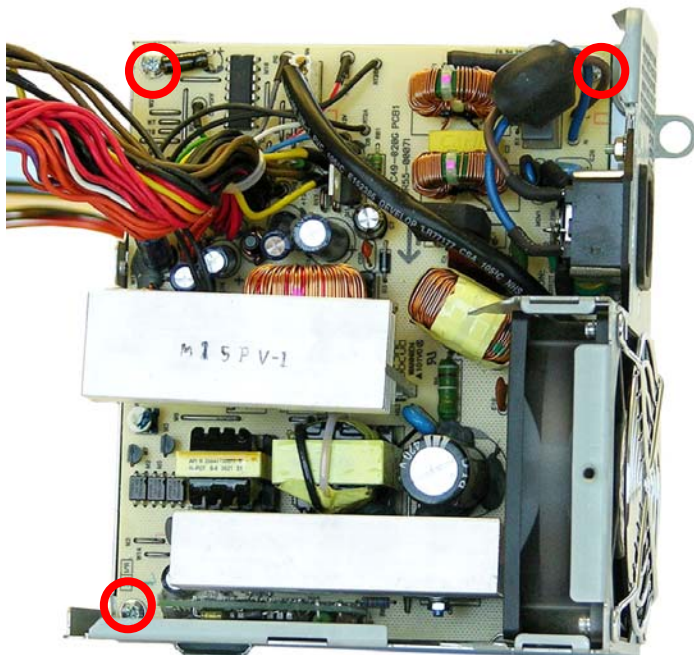

FIGURE 18: Power supply 2 – Capacitors (2) and small PCA (1) to cut

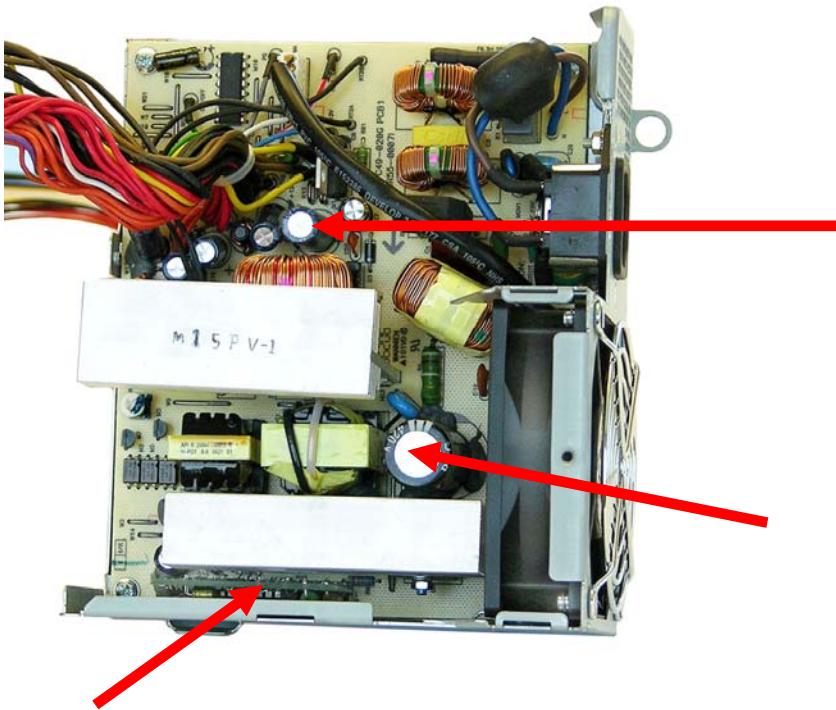

FIGURE 19: Power supply 3 – Cover screw locations

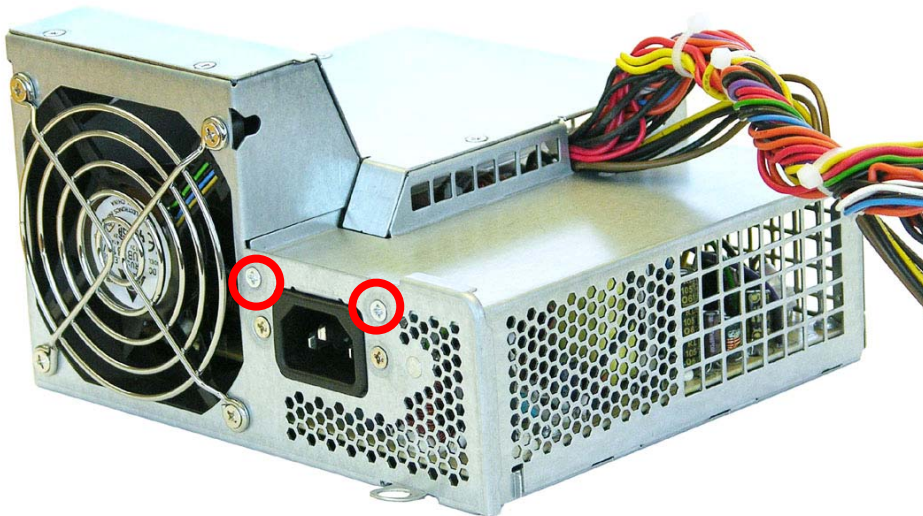

FIGURE 20: Power supply 3 – Cover screw and plastic tie locations

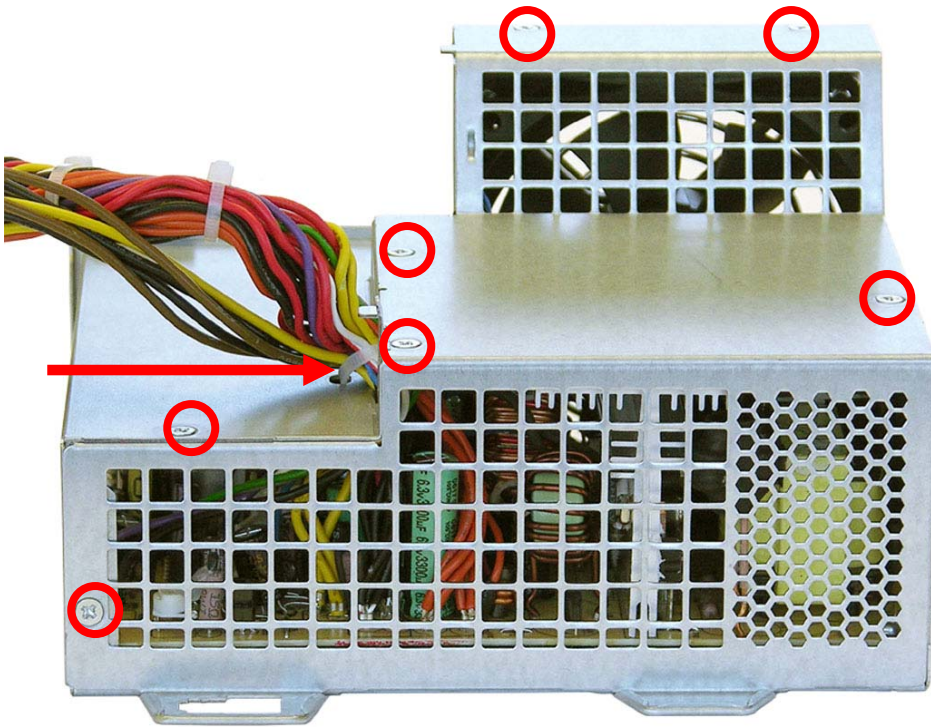

FIGURE 21: Power supply 3 – PCA screw locations

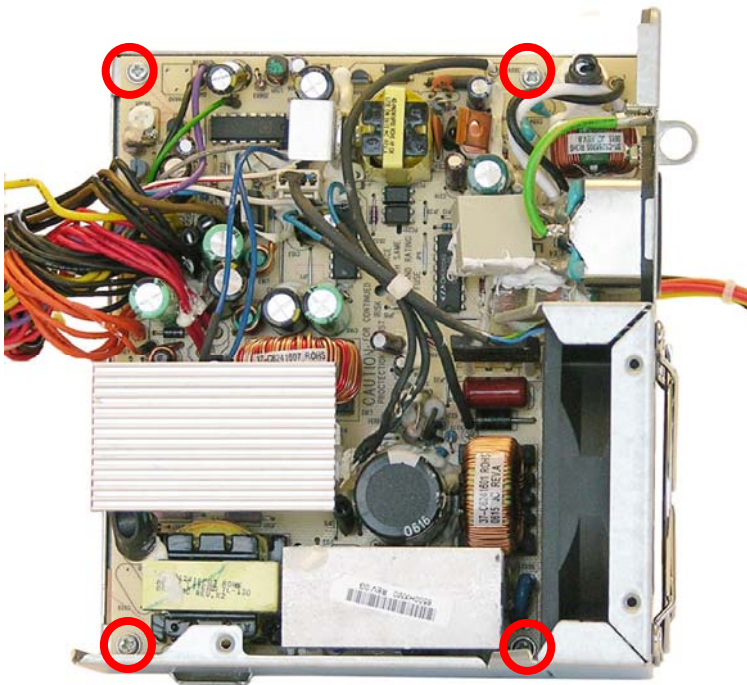

FIGURE 22: Power supply 3 – Capacitors to cut (7)

