



Product End-of-Life Disassembly Instructions

Product Category: Personal Computers

Marketing Name / Model

[List multiple models if applicable.]

HP Compaq dc7900 Ultra Slim Desktop Business PC

Name / Model #2

Purpose: The document is intended for use by end-of-life recyclers or treatment facilities. It provides the basic instructions for the disassembly of HP products to remove components and materials requiring selective treatment, as defined by EU directive 2002/96/EC, Waste Electrical and Electronic Equipment (WEEE).

1.0 Items Requiring Selective Treatment

1.1 Items listed below are classified as requiring selective treatment.

1.2 Enter the quantity of items contained within the product which require selective treatment in the right column, as applicable.

Item Description	Notes	Quantity of items included in product
Printed Circuit Boards (PCB) or Printed Circuit Assemblies (PCA)	With a surface greater than 10 sq cm	1
Batteries	All types including standard alkaline and lithium coin or button style batteries	1
Mercury-containing components	For example, mercury in lamps, display backlights, scanner lamps, switches, batteries	
Liquid Crystal Displays (LCD) with a surface greater than 100 sq cm	Includes background illuminated displays with gas discharge lamps	
Cathode Ray Tubes (CRT)		
Capacitors / condensers (Containing PCB/PCT)		
Electrolytic Capacitors / Condensers measuring greater than 2.5 cm in diameter or height		
External electrical cables and cords		
Gas Discharge Lamps		
Plastics containing Brominated Flame Retardants		
Components and parts containing toner and ink, including liquids, semi-liquids (gel/paste) and toner	Include the cartridges, print heads, tubes, vent chambers, and service stations.	
Components and waste containing asbestos		
Components, parts and materials containing refractory ceramic fibers		
Components, parts and materials containing radioactive substances		

1.3 Markings for plastic parts greater than 25 grams

Plastic Part Name	Plastic Part Description	Weight (grams)	ISO 11469:2000 Plastic Part Mark	Optional: Photo
MAIN BEZEL	BEZEL, MAIN, USDT, BEARS	63 g	>ABS<	
CABLECOVER	P_PANDA-USDT-CABLECOVER	349 g	>PC+ABS FR(40)<	
TOWER STAND	P_TOWER_STAND	135 g	>ABS<	
FAN DUCT	FAN DUCT, USDT, BEARS	31 g	>PC+ABS FR(40)<	

2.0 Tools Required

List the type and size of the tools that would typically be used to disassemble the product to a point where components and materials requiring selective treatment can be removed.

Tool Description	Tool Size (if applicable)
Description #1 Phillips screwdriver	
Description #2 Dikes	
Description #3 Torx screwdriver	T-15

3.0 Product Disassembly Process

3.1 List the basic steps that should typically be followed to remove components and materials requiring selective treatment:

1. To remove the access panel, loosen the thumbscrew on the rear of the computer (1), slide the access panel toward the front of the computer, then lift it off (2) (see Figure 1).
2. To remove the front bezel:
 - a. Lift the fan and shroud assembly up and place it on top of the optical drive to access the front bezel release tabs (see Figure 2).
 - b. Press the two release tabs on the inside of the bezel towards the right side of the computer (1) and rotate the bezel off from right to left (2) (see Figure 3).
3. Remove or cut all expansion cards, cables, and any other devices from the system board.
4. To remove the system board:
 - a. Remove the hard drive cage.
 - b. Remove the front I/O panel.
 - c. Remove the heatsink from the system board by loosening the four captive screws that secure the heatsink to the system board, and then lifting the heatsink from the system board.
 - d. Remove the five screws that secure the system board to the chassis (see Figure 4).
 - e. Slide system board toward the front of the unit until the rear connectors are clear of their slots in the chassis.
5. To remove the battery:

Locate the battery and battery holder on the system board. Depending on the type of battery holder on the system board, complete the following instructions to remove the battery.

TYPE 1 BATTERY HOLDER (see Figure 5):
Lift the battery out of the holder.

TYPE 2 BATTERY HOLDER (see Figure 6):
To release the battery from its holder, squeeze the metal clamp that extends above one edge of the battery. When the battery pops up, lift it out.

TYPE 3 BATTERY HOLDER (see Figure 7):
Pull back on the clip that holds the battery in place, and then remove the battery.

3.2 Optional Graphic. If the disassembly process is complex, insert a graphic illustration below to identify the items contained in the product that require selective treatment (with descriptions and arrows identifying locations).

FIGURE 1: Removing the access panel.



FIGURE 2: Lifting the fan shroud

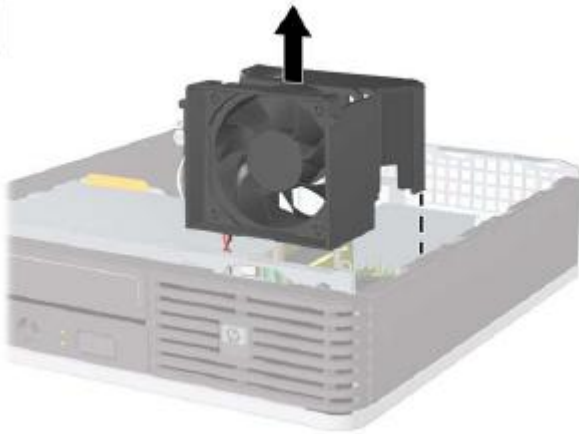

FIGURE 3: Removing the front bezel

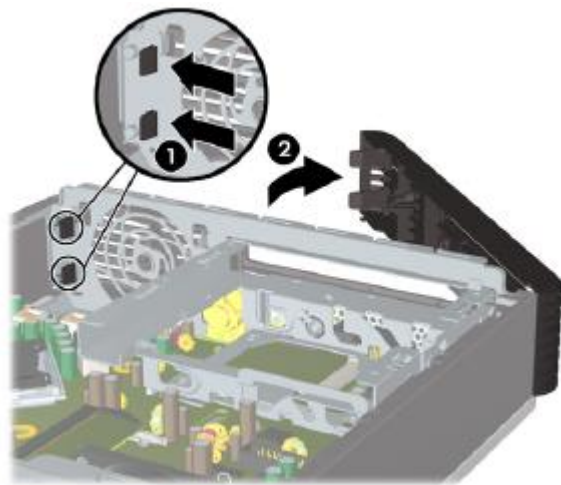

FIGURE 4: Removing the system board



FIGURE 5: Type 1 battery holder

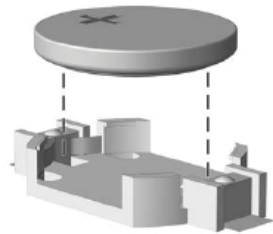

FIGURE 6: Type 2 battery holder



FIGURE 7: Type 3 battery holder

