



HP LASERJET P3010

SERIES PRINTER

Software Technical Reference



Additional product information:
www.hp.com/support/ljp3010series



HP LaserJet P3010 Series Printers

Software Technical Reference

Copyright and license

©2009 Copyright Hewlett-Packard Development Company, L.P.

Reproduction, adaptation or translation without prior written permission is prohibited, except as allowed under the copyright laws.

The information contained herein is subject to change without notice.

The only warranties for HP products and services are set forth in the express warranty statements accompanying such products and services. Nothing herein should be construed as constituting an additional warranty. HP shall not be liable for technical or editorial errors or omissions contained herein.

Edition 1, 8/2009

Trademark Credits

Adobe®, Acrobat® and PostScript® are trademarks of Adobe Systems Incorporated.

Corel® is a trademark or registered trademark of Corel Corporation or Corel Corporation Limited.

Microsoft®, Windows® and Windows NT® are U.S. registered trademarks of Microsoft Corporation.

Windows Vista™ is either a registered trademark or trademark of Microsoft Corporation in the United States and/or other countries.

UNIX® is a registered of The Open Group.

ENERGY STAR® and the ENERGY STAR logo® are U.S. registered marks of the United States Environmental Protection Agency.

Table of contents

1 Purpose and scope

Introduction	2
Product comparison	3
Product features	5
Quick Reference Job Aids	7
Product views	8
Front view	8
Rear view	9
Printing-system software	10
Operating-system support	10
Supported operating systems for Windows	11
Supported printer drivers for Windows	11
HP Universal Print Driver (UPD)	11
UPD installation modes	12
Supported utilities for Windows	12
HP Web Jetadmin	12
Embedded Web Server	12
HP Easy Printer Care	13
Supported operating systems for Macintosh	13
Supported printer drivers for Macintosh	13
Supported utilities for Macintosh	14
HP Printer Utility	14
Embedded Web Server	15
Software for other operating systems	15
Printer driver support in other operating systems	15
Availability	16
Software component availability for Windows and Macintosh	16
Printing-system software on the Web	17
In-box printing-system software CD	17
Printing-system software CD	18
CD Versions	18
Documentation availability and localization	23
Printing-system software CD	24
Main browser screen	24

Administrator Documentation	25
HP Embedded Web Server User Guide	25
HP Jetdirect Administrator's Guide	26
HP Driver Preconfiguration Support Guide	26
User Documentation	27
User Guide	27
HP LaserJet P3010 Series Printing-System Install Notes	28
Support	29

2 Software description

Windows printing-system software	32
Supported operating systems for Windows	32
Windows system requirements	32
Macintosh system requirements	33
Printer driver	33
Select the correct printer driver for Windows	33
Priority for print settings	34
Change printer-driver settings for Windows	35
Printing system and installer	36
Printing-system software CD for Windows systems	36
Installer features	40
Driver version numbers for Windows operating systems	41
Windows printer-driver configuration	42
Printer-driver autoconfiguration	42
Bidirectional communication	42
Enterprise AutoConfiguration	43
Update Now	43
HP Web Jetadmin	44
Configurable settings	45
Continuous export	46
HP Driver Diagnostic Printer Check Tool	48
Embedded Web Server	49
HP Web Jetadmin	50
Font support	51
Basic Windows fonts	51
Default printing-system fonts	51

3 Install Windows printing-system components

Supported operating systems for Windows	58
Windows operating system requirements	58
Install overview	58
Software installation types for Windows	58
Installation options	59

Microsoft Windows general installation overview	60
HP LaserJet P3010 Series printing-system software CD for Windows systems	60
Install Now	61
Advanced Install Options	61
Administrator Documentation	62
Administrator Software	63
User Documentation	64
User Guide	64
User Guide	65
HP LaserJet P3010 Series Printing-System Install Notes	66
Support	67
Additional Options	68
Microsoft Windows installation for direct connections (Plug and Play)	68
Install from the printing-system software CD	69
Install the print driver using the Microsoft Add Printer Wizard	69
Use an existing port for a direct connection	71
Create a new TCP/IP port for a direct connection	75
Print server connection	78
Microsoft Windows installation for computers on a network	81
Point and Print installation for Windows 2000 Service Pack 3, XP, Server 2003, Server 2008, and Vista	87
Detailed MS Windows installation instructions	89
Perform the recommended print driver installation using the HP Driver Installation Utility (HPDIU)	89
Use the Back, Next, Finish, and Cancel buttons	97
Performing an advanced print driver installation using the HP Driver Installation Utility (HPDIU)	98
Set a default printer	107
Install documentation and optional software	108
Uninstall software	110

4 HP PCL 6 Print Driver for Windows

Introduction	111
Gain access to print drivers	113
Printing Preferences driver tabs	113
Properties driver tabs	114
Help system	115
“What's this?” Help	115
Incompatible Print Settings messages	115
Advanced tab features	116
Paper/Output	116
Copy Count	117
Graphic	117
TrueType Font	117

Document Options	117
Advanced Printing Features	117
Print Optimizations	118
Printer Features	118
Layout Options	119
Printing Shortcuts tab features	120
Use defined printing shortcuts	120
General Everyday Printing	121
Paper source	121
Paper sizes	121
Paper type	122
Orientation	122
Print on both sides	123
Pages per sheet	123
Eco-print (Two-sided Printing)	123
Envelopes	123
Booklet Printing	124
Factory Defaults	124
Create a custom printing shortcut	124
Paper/Quality tab features	126
Paper Options	127
Paper sizes	127
Custom Paper Size	128
Name	128
Paper Size	128
Units	129
Custom width and height control limits	129
Paper source	129
Paper type	130
Special pages	131
Covers	131
Print pages on different paper	132
Insert blank or preprinted sheets	133
Chapter separator pages	133
Document preview image	133
Print Quality	133
Print Quality drop-down menu	133
EconoMode check box	133
Effects tab features	135
Resizing Options	135
Actual size	136
Print document on	136
Scale to fit	136
% of actual size	136

Document preview image	137
Watermarks	137
Current Watermarks	138
Watermark Message	139
Message Angle	139
Font Attributes	139
Default watermark settings	140
Finishing tab features	141
Document Options	141
Print on both sides	142
Print on both sides (automatically)	143
Print on both sides manually	143
Flip pages up	145
Booklet layout	145
Book and booklet printing	145
Pages per sheet	146
Print page borders	146
Page order	146
Job Separator	147
Document preview image	147
Orientation	148
Job Storage tab features	149
Status group box	151
Job Storage Mode	151
Off	151
Proof and Hold	151
Personal Job	152
Quick Copy	152
Stored Job	152
PIN to print	153
Job Notification Options	153
User Name	153
Job Name	154
Use job-storage features when printing	154
Release a job-storage print job	155
Delete a job-storage print job	155
Services tab features	156
Internet Services	156
Device Services	157
Device Settings tab features	158
Form to Tray Assignment	158
Font Substitution Table	159
External Fonts	159
Installing external fonts	160

Remove external fonts	161
Installable Options	161
Automatic Configuration	161
Printer Status Notification	162
Tray 3 and Tray 4	162
Duplex Unit (for 2-Sided Printing)	162
Allow Manual Duplexing	162
Printer Memory	162
Printer Hard Disk	162
Job Storage	162
Job Separator	163
Mopier Mode	163
Mopier mode and collation	163
About tab features	164

5 Macintosh software and utilities

Supported operating systems for Macintosh	166
Macintosh system requirements	166
Macintosh printing-system software	166
HP LaserJet P3010 Series PPD	166
HP LaserJet P3010 Series PDE	167
HP USB EWS Gateway	167
HP Printer Utility	167
Supported printer drivers for Macintosh	167
Priority for print settings for Macintosh	167
Change printer-driver settings for Macintosh	168
Software for Macintosh computers	168
HP Printer Utility	168
Open the HP Printer Utility	168
HP Printer Utility features	168
Embedded Web Server	169
Availability	169
Printing-system software on the Web	169
In-box printing-system software CD	170
Macintosh partition	170
CD versions	170
Macintosh install and uninstall instructions	173
Install the Macintosh printing-system software	173
General installation for Macintosh operating systems	173
Detailed Mac OS X installation	174
Setup instructions	181
Setting up a printer with Mac OS X v10.4, v10.5, and later	181
Setting up a printer with Mac OS X v10.3.9	183

Troubleshooting the product setup	185
Remove the printing-system software from Macintosh operating systems	185
HP Printer Utility for Macintosh	186
Access to the HP Printer Utility	186
Supplies Status	187
Device Information	188
File Upload	188
Remote firmware update by using the HP Printer Utility	189
Upload Fonts	190
HP Support	191
Duplex mode	192
Economode & Toner Density	193
Resolution	194
Trays Configuration	195
Stored Jobs	196
E-mail Alerts	196
Network Settings	197
Protect Direct Ports	199
Additional Settings	199
Supplies Management	200
Use features in the Macintosh printer driver	201
Create and use printing presets in Macintosh	201
Resize documents or print on a custom paper size	201
Print a cover page	201
Use watermarks	202
Print multiple pages on one sheet of paper in Macintosh	202
Print on both sides of the page (duplex printing)	203
Store jobs	203
Use the Services menu	204

6 Engineering Details

Introduction	205
Remote firmware update	206
Determining the current level of firmware	206
Downloading the new firmware from the HP Web site	206
Downloading the new firmware to the product	206
Printer messages during the firmware update	207
Remote firmware update by using FTP through a browser	208
Remote firmware update by using FTP on a direct network connection	209
Windows operating systems	209
Macintosh operating systems	210
Remote firmware update through a local Windows port	211
Windows 2000 Service Pack 3, Windows XP, Windows Server 2003, or Windows Server 2008	211

Remote firmware update through a USB port	212
Remote firmware update through a Windows network	213
Remote firmware update for UNIX systems	213
Remote firmware update by using the LPR command	213
HP Easy Firmware Upgrade utility	214
Remote firmware update through HP Web Jetadmin	217
Printing print-ready documents	219
Print-ready file printing by using FTP through a browser	219
Print-ready file printing by using FTP on a direct network connection	219
Windows operating systems	220
Macintosh operating systems	221
Print-ready printing by using a local Windows port	221
Windows 2000 Service Pack 3, Windows XP, Windows Server 2003, Windows Server 2008, or Windows Vista	222
Print-ready file printing in a Windows network	222
Print-ready file printing in UNIX systems	222
Print-ready file printing by using the LPR command	222
Media attributes	224
Paper sources and destinations	224
Paper-source commands	224
Driver-supported paper sizes	225
Driver-supported paper types	227
Custom paper sizes	228
Paper-type commands	228
Index	231

List of tables

Table 1-1	UPD installation modes	12
Table 1-2	HP Easy Printer Care support	13
Table 1-3	HP Printer Utility features	14
Table 1-4	Software for other operating systems	15
Table 1-5	Software component availability	16
Table 1-6	Supported printing-system components (AR-ET)	20
Table 1-7	Supported printing-system components (FI-KO)	20
Table 1-8	Supported printing-system components (LT-SL)	21
Table 1-9	Supported printing-system components (SR-ZHT)	22
Table 2-1	Change printer-driver settings for Windows	35
Table 2-2	Availability of automatic discovery and printer- driver configuration through bidirectional communication in Windows	42
Table 2-3	Default fonts	51
Table 2-4	Additional PS emulation fonts	53
Table 4-1	PCL 6 custom paper sizes	129
Table 4-2	Font Attribute settings for new and preset watermarks	140
Table 4-3	Page orientation	145
Table 4-4	Driver Mopier Mode: and collation settings	163
Table 5-1	HP Printer Utility features	169
Table 5-2	Adding a product in Macintosh operating systems	173
Table 6-1	Troubleshooting a firmware update	207
Table 6-2	Troubleshooting a firmware update failure	207
Table 6-3	Update messages	208
Table 6-4	HP LaserJet P3010 Series paper sources and destinations	224
Table 6-5	Paper-source commands ¹	224
Table 6-6	Supported paper and print media sizes	225
Table 6-7	HP PCL 6 print driver custom paper sizes	228
Table 6-8	paper-type commands	228

List of figures

Figure 1-1	Printing-system software CD – main browser screen	24
Figure 1-2	Administrator Documentation screen	25
Figure 1-3	User Documentation screen	27
Figure 1-4	Online Support screen	29
Figure 2-1	Installation software CD Browser	36
Figure 2-2	Advanced Installation Options	37
Figure 2-3	Administrator Software screen	38
Figure 2-4	Administrator Documentation screen	39
Figure 2-5	Online Support screen	40
Figure 3-1	CD Browser – Main screen	60
Figure 3-2	CD Browser – Advanced Installation Options	61
Figure 3-3	CD Browser–Administrator Documentation screen	62
Figure 3-4	CD Browser – Administrator Software screen	63
Figure 3-5	User Documentation screen	64
Figure 3-6	CD Browser–Support screen	67
Figure 3-7	CD Browser – Additional Options screen	68
Figure 3-8	Add Printer Wizard – Local or Network Printer screen	70
Figure 3-9	Add Printer Wizard — Select a Printer Port screen	71
Figure 3-10	Add Printer Wizard — Install Printer Software screen	72
Figure 3-11	Add Printer Wizard — Install from Disk screen	72
Figure 3-12	Add Printer Wizard — Install Printer Software, screen 2	73
Figure 3-13	Add Printer Wizard — Name Your Printer screen	73
Figure 3-14	Add Printer Wizard — Printer Sharing screen	74
Figure 3-15	Add Printer Wizard — Print Test Page screen	74
Figure 3-16	Select a Printer Port screen	75
Figure 3-17	Add Standard TCP/IP Printer Port screen	76
Figure 3-18	Add Port screen	77
Figure 3-19	Add Printer Wizard — Local or Network Printer screen	78
Figure 3-20	Add Printer Wizard — Specify A Printer screen	79
Figure 3-21	Add Printer Wizard — Find Printers screen	80
Figure 3-22	Add Printer Wizard — Default Printer screen	80
Figure 3-23	Add Printer Wizard — Browse for Printer screen	81
Figure 3-24	Software Installation — License Agreement screen	82
Figure 3-25	Software Installation — Device Connection screen	83

Figure 3-26	Device Connection — Devices Found screen	84
Figure 3-27	Software Installation — Device Connection screen 2	85
Figure 3-28	Software Installation — Driver Installation Complete – Direct Connection	86
Figure 3-29	Software Installation — Driver Installation Complete – Network connection	87
Figure 3-30	Software Installation — Initial screen	90
Figure 3-31	Software Installation — License Agreement screen	91
Figure 3-32	Software Installation — Device Connection screen	92
Figure 3-33	Software Installation — Devices Found screen	93
Figure 3-34	Software Installation — Device Connection	94
Figure 3-35	Software Installation — Driver Installation Complete – Direct Connection	95
Figure 3-36	Software Installation — Driver Installation Complete – Network connection	96
Figure 3-37	Additional Options	97
Figure 3-38	Installation Cancelled dialog box	98
Figure 3-39	Software Installation — Initial screen	99
Figure 3-40	Software Installation — Advanced Installation Options screen	100
Figure 3-41	Software Installation — License Agreement screen	101
Figure 3-42	Software Installation — Device Connection screen	102
Figure 3-43	Software Installation — Devices Found	103
Figure 3-44	Software Installation — Device Connection	104
Figure 3-45	Software Installation — Driver Installation Complete screen	105
Figure 3-46	Software Installation — Driver Installation Complete screen 2	106
Figure 3-47	Software Installation — Additional Options screen	107
Figure 3-48	Install or Uninstall Software	109
Figure 3-49	Uninstall	110
Figure 4-1	An Incompatible Print Settings message	115
Figure 4-2	The default appearance of the Advanced tab	116
Figure 4-3	Printing Shortcuts tab	120
Figure 4-4	Printing Shortcuts dialog box	124
Figure 4-5	Printing Shortcuts tab—Custom shortcut	125
Figure 4-6	Paper/Quality tab	126
Figure 4-7	Paper Options group box	127
Figure 4-8	Custom Paper Size dialog box	128
Figure 4-9	Type is: dialog box	130
Figure 4-10	Print pages on different paper —First or Last	132
Figure 4-11	Effects tab	135
Figure 4-12	Preview images – Legal on Letter; Scale to Fit off (left) and on (right)	136
Figure 4-13	Watermark Details dialog box	138
Figure 4-14	Finishing tab	141
Figure 4-15	Print on Both Sides Instructions dialog box	144
Figure 4-16	Page-order preview images	146
Figure 4-17	Separator Page Details dialog box	147
Figure 4-18	Job Storage tab	150
Figure 4-19	Services tab	156
Figure 4-20	Device Settings tab	158

Figure 4-21	Font Substitution Table	159
Figure 4-22	HP Font Installer dialog box	160
Figure 4-23	About tab	164
Figure 5-1	Product CD image	174
Figure 5-2	HP LaserJet installer browser screen	175
Figure 5-3	Introduction dialog box	176
Figure 5-4	Software License Agreement dialog box	176
Figure 5-5	Agree/Disagree dialog box	177
Figure 5-6	Select a Destination dialog box	178
Figure 5-7	Installation Type dialog box	178
Figure 5-8	Custom Install dialog box	179
Figure 5-9	Authenticate dialog box	180
Figure 5-10	Installing dialog box	180
Figure 5-11	Install Succeeded dialog box	181
Figure 5-12	Supplies Status screen	187
Figure 5-13	Device Information screen	188
Figure 5-14	File Upload screen	188
Figure 5-15	Upload Fonts screen	190
Figure 5-16	HP Online Support screen	191
Figure 5-17	Duplex Mode	192
Figure 5-18	Economode & Toner Density screen	193
Figure 5-19	Resolution screen	194
Figure 5-20	Trays Configuration screen	195
Figure 5-21	Enable Job Storing screen	196
Figure 5-22	E-mail Alerts screen	197
Figure 5-23	IPv4 Settings screen	197
Figure 5-24	Protect Direct Ports screen	199
Figure 5-25	Additional Settings screen	199
Figure 5-26	Replace Supplies screen	200
Figure 6-1	HP Easy Firmware Upgrade utility screen 1	215
Figure 6-2	HP Easy Firmware Upgrade utility screen 2	215
Figure 6-3	HP Easy Firmware Upgrade utility progress screen	216
Figure 6-4	HP Easy Firmware Upgrade utility complete screen	216

1 Purpose and scope

Introduction

This software technical reference (STR) provides information about and troubleshooting tips for the printing-system software for the product.

This STR is prepared in an electronic format to serve as a quick-reference tool for Customer Care Center (CCC) agents, support engineers, system administrators, management information systems (MIS) personnel, and end users, as appropriate.

 **NOTE:** This STR describes drivers that are shipped on the printing-system software CD that comes with the product. This STR does *not* describe drivers that will become available on the Web.

The following information is included in this STR:

- Descriptions of drivers, operating systems, and system environments
- Procedures for installing and uninstalling the printing-system software components

For information about the location of information within chapters, see the table of contents. An index is also provided in this STR.

Additional detailed information about the printing-system software is published in an addendum to this STR. The following information is available in the addendum:

- Lists of installed files
- System-modification information, such as files added or modified

Product comparison

HP LaserJet P3015 printer (base model)

CE525A

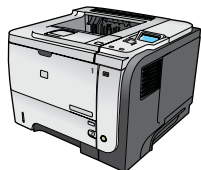

- Prints up to 42 pages per minute (ppm) on Letter size paper and 40 ppm on A4 size paper
- Contains 96 megabytes (MB) of random access memory (RAM). Expandable to 1 GB.
- Tray 1 holds up to 100 sheets
- Tray 2 holds up to 500 sheets
- 250-sheet face-down output bin
- 50-sheet face-up output bin
- 4-line graphical control-panel display
- Hi-speed USB 2.0 port
- USB port on the front of the product for walk-up printing
- Enhanced input/output (EIO) slot
- One open dual inline memory module (DIMM) slot

HP LaserJet P3015d printer

CE526A

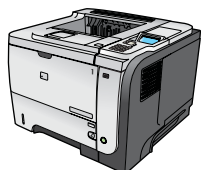

Has the same features as the HP LaserJet P3015 printer, with the following differences:

- 10-key numeric keypad on the control panel
- Automatic two-sided (duplex) printing
- Contains 128 MB RAM. Expandable to 1 GB
- Hardware integration pocket for installing third-party security devices

HP LaserJet P3015n printer

CE527A

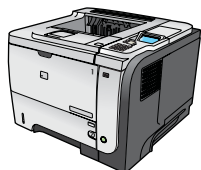

Has the same features as the HP LaserJet P3015 printer, with the following differences:

- 10-key numeric keypad on the control panel
- Embedded HP Jetdirect networking
- Contains 128 MB RAM. Expandable to 1 GB
- Hardware integration pocket for installing third-party security devices

HP LaserJet P3015dn printer

CE528A

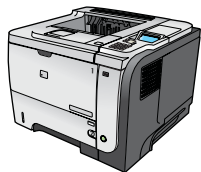

Has the same features as the HP LaserJet P3015 printer, with the following differences:

- 10-key numeric keypad on the control panel
- Automatic two-sided (duplex) printing
- Embedded HP Jetdirect networking
- Contains 128 MB RAM. Expandable to 1 GB
- Hardware integration pocket for installing third-party security devices

HP LaserJet P3015x printer

CE529A

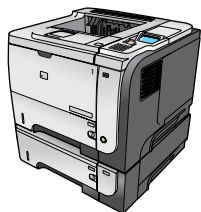

Has the same features as the HP LaserJet P3015 printer, with the following differences:

- 10-key numeric keypad on the control panel
 - Automatic two-sided (duplex) printing
 - Embedded HP Jetdirect networking
 - Contains 128 MB RAM. Expandable to 1 GB
 - One additional 500-sheet input tray (Tray 3)
 - Hardware integration pocket for installing third-party security devices
-

Product features

Feature	Description
Performance	<ul style="list-style-type: none"> 540 MHz processor
User interface	<ul style="list-style-type: none"> Control-panel help 4-line graphical display with numeric keypad. (The keypad is not included for the base model) HP Easy Printer Care software (a Web-based status and problem-solving tool) Windows® and Macintosh printer drivers Embedded Web server to access support and order supplies (for network-connected models only)
Printer drivers	<ul style="list-style-type: none"> HP PCL 5 Universal Print Driver for Windows (HP UPD PCL 5) HP PCL 6 HP postscript emulation Universal Print Driver for Windows (HP UPD PS)
Resolution	<ul style="list-style-type: none"> FastRes 1200 – emulates 1200-dots-per-inch (dpi) print quality for fast, high-quality printing of business text and graphics ProRes 1200 – produces 1200-dpi printing for the best quality in line art and graphic images 600 dpi – provides the fastest printing
Storage features	<ul style="list-style-type: none"> Fonts, forms, and other macros Job retention
Fonts	<ul style="list-style-type: none"> 103 internal scalable fonts available for PCL and 93 for HP UPD postscript emulation 80 device-matching screen fonts in TrueType format available with the software solution Additional fonts can be added through USB
Accessories	<ul style="list-style-type: none"> HP 500-sheet input tray (up to two additional trays)
Connectivity	<ul style="list-style-type: none"> Hi-Speed Host USB 2.0 connection HP Jetdirect full-featured embedded print server (for the n, dn, and x models only) with IPv4, IPv6, and IP Security. USB port on the front of the product for walk-up printing HP Web Jetadmin software Enhanced input/output (EIO) slot
Supplies	<ul style="list-style-type: none"> The supplies status page contains information about toner level, page count, and estimated percent of life remaining. For information about print cartridges, see www.hp.com/go/learnaboutequipment. The product checks for an authentic HP print cartridge at installation. Internet-enabled supply-ordering capabilities (using HP Easy Printer Care)

Feature	Description
Supported operating systems	<ul style="list-style-type: none">• Microsoft® Windows® 2000 Service Pack 3, Windows® XP, Windows Server 2003, Windows Server 2008, and Windows Vista®• Macintosh OS X V10.3, V10.4, V10.5, and later• Novell NetWare• UNIX®• Linux
Security	<ul style="list-style-type: none">• Secure Disk Erase• Security lock (optional)• Job retention• User PIN authentication for stored jobs• IPsec security• HP encrypted High Performance EIO hard drive (optional)• Hardware integration pocket for installing third-party security devices (not included for the base model)
Accessibility	<ul style="list-style-type: none">• The online user guide is compatible with text screen-readers.• The print cartridge can be installed and removed by using one hand.• All doors and covers can be opened by using one hand.• Paper can be loaded in Tray 1 by using one hand.

Quick Reference Job Aids

Quick Reference Job Aids provide additional step-by-step procedures for using this product. Gain access to the Quick Reference Job Aids from the user CD or at <http://www.hp.com/go/showmehow/ljp3010>.

Product views

Front view

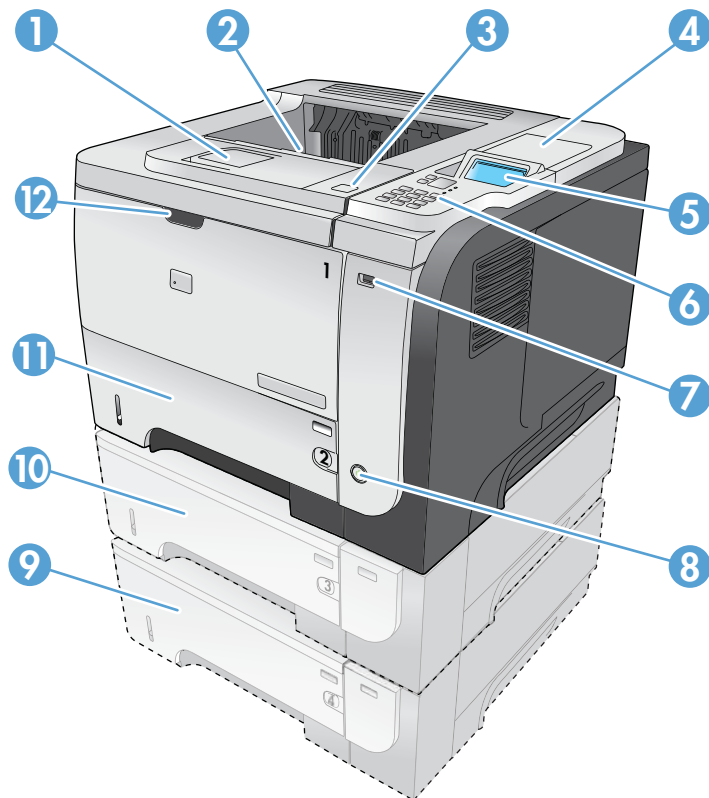

1	Extension for the top output bin
2	Top output bin
3	Top cover (provides access to the print cartridge and the label that lists the model and serial number)
4	Hardware integration pocket for installing third-party security devices (not included for the base model)
5	Control-panel display
6	Control-panel buttons (the 10-key numeric keypad is not available on the base model)
7	USB port for walk-up printing
8	On/off button
9	Optional Tray 4
10	Optional Tray 3 (included with the x model)
11	Tray 2
12	Tray 1 (pull to open)

Rear view

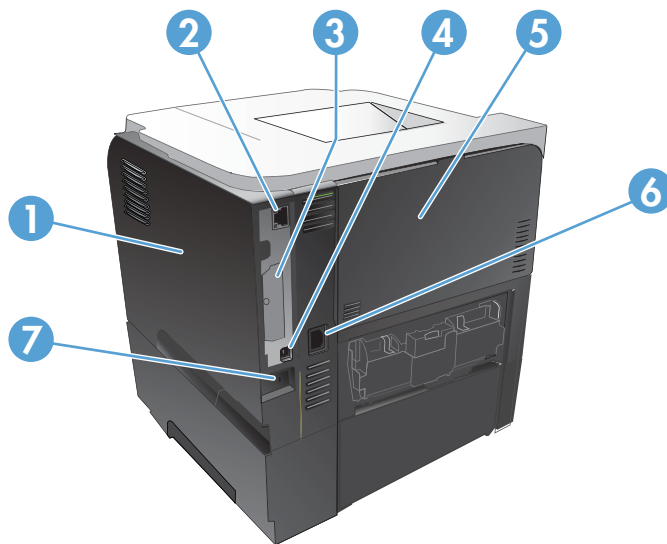

1	Right-side cover (provides access to the DIMM slot and additional USB ports)
2	RJ.45 network connection (for the n, dn, and x models only)
3	EIO slot (covered)
4	Hi-speed USB 2.0 connection, for connecting directly to a computer
5	Rear door (pull open to a 45° angle for straight-through printing and to a 90° angle to clear jams)
6	Power connection
7	Slot for a cable-type security lock

Printing-system software

- [Operating-system support](#)
- [Availability](#)

Operating-system support

Windows operating systems provide full-featured support for the product. Operating systems that are not described in this STR provide varying levels of functionality.

Throughout this document, Windows XP is used to denote Windows XP Home Edition and Windows XP Professional, unless noted otherwise.

Information relating to networking functions is specific to products that have network capabilities.

The printing-system software has *not* been tested with and is *not* supported in the following operating systems:

- Windows 3.1x
- Windows 95
- Windows 98
- Windows Millennium Edition (Me)
- Windows NT® 4.0
- IA-64-bit operating systems

Printer drivers for these operating systems are not included on the printing-system software CD and are not available on the Web. Other printer drivers might work with the product, but some print-driver features and functions might not be available.

For more information about the product, go to the following Web site:

www.hp.com/support/ljp3010

- [Supported operating systems for Windows](#)
- [Supported printer drivers for Windows](#)
- [HP Universal Print Driver \(UPD\)](#)
- [Supported utilities for Windows](#)
- [Supported operating systems for Macintosh](#)
- [Supported printer drivers for Macintosh](#)
- [Supported utilities for Macintosh](#)
- [Software for other operating systems](#)
- [Printer driver support in other operating systems](#)

Supported operating systems for Windows

The product supports the following Windows operating systems:

- Windows 2000 Service Pack 3 (32-bit)
- Windows XP (32-bit and 64-bit)
- Windows Server 2003 (32-bit and 64-bit)
- Windows Vista (32-bit and 64-bit)
- Windows Server 2008 (32-bit and 64-bit)

Supported printer drivers for Windows

- HP PCL 6 Printer Driver
- HP PCL 6 Universal Print Driver (HP PCL6 UPD)
- HP PostScript Emulation Universal Print Driver (HP PS Emulation UPD)
- HP PCL 5 Universal Print Driver (HP PCL 5 UPD)

The printer drivers include online Help that has instructions for common printing tasks and also describes the buttons, check boxes, and drop-down lists that are in the printer driver.

 **NOTE:** The HP PCL 6 is the only printer driver that is included with this product; it is included in the box on the printing-system CD.

NOTE: For more information about the UPD, see www.hp.com/go/upd.

HP Universal Print Driver (UPD)

Each HP Universal Print Driver (UPD) for Windows is a single driver that gives you instant access to virtually any HP LaserJet product, from any location, without downloading separate drivers. It is built on proven HP print driver technology and has been tested thoroughly and used with many software programs. It is a powerful solution that performs consistently over time.

The HP UPD communicates directly with each HP product, gathers configuration information, and then customizes the user interface to show the product's unique, available features. It automatically enables features that are available for the product, such as two-sided printing and stapling, so you do not need to enable them manually.

For more information, go to www.hp.com/go/upd.

When you download and install a UPD from the product support Web page (www.hp.com/support/ljp3010), there will be some variations in the installation process and results depending on the driver that you select.

From the support page, click on the **Download Drivers and Software** link. After you select the printer model and operating system, there will be several selections on the download page. You can download drivers from the "Driver" section and from the "Driver - Universal Print Driver" section.

Drivers downloaded from the "Driver" section are wrapped with the HP DIU (Driver Installation Utility) and produce a "named" driver when installed. A named driver has the printer model number in the driver print queue name. These drivers always install in Traditional mode. The HP PCL 6 Print Driver is a product specific driver, and the PCL5 and postscript driver are UPDs but install as described.

Drivers downloaded from the “Driver-Universal Print Driver” section includes the UPD installer. For these drivers, the driver print queue shows a non-product-specific name. When installing these drivers, you have a choice between Traditional or Dynamic mode as described below.

UPD installation modes

Table 1-1 UPD installation modes

Traditional mode	<ul style="list-style-type: none"> • Use this mode if you are installing the driver from a CD for a single computer. • When installed with this mode, UPD operates like traditional printer drivers. • If you use this mode, you must install UPD separately for each printer.
Dynamic mode	<ul style="list-style-type: none"> • Use this mode if you are installing the driver for a mobile computer, so you can discover and print to HP products in any location. • Use this mode if you are installing UPD for a workgroup. • To use this mode, download UPD from the Internet. See www.hp.com/go/upd.

Supported utilities for Windows

The following utilities for Windows are available for the HP LaserJet P3010 Series printer.

HP Web Jetadmin

HP Web Jetadmin is a browser-based management tool for HP Jetdirect-connected printers within your intranet, and it should be installed only on the network administrator’s computer.

To download a current version of HP Web Jetadmin and for the latest list of supported host systems, visit www.hp.com/go/webjetadmin.

When installed on a host server, a Windows client can gain access to HP Web Jetadmin by using a supported Web browser (such as Microsoft® Internet Explorer 4.x or Netscape Navigator 4.x or later) by navigating to the HP Web Jetadmin host.

For a complete explanation of the features and functionality of HP Web Jetadmin, see the *HP Jetdirect Print Servers Administrator’s Guide*, which is available on the printing system software CD.

Embedded Web Server

The product is equipped with the HP Embedded Web Server (HP EWS), which provides access to information about product and network activities. This information appears in a Web browser, such as Microsoft Internet Explorer, Netscape Navigator, Apple® Safari, or Firefox.

The HP EWS resides on the product. It is not loaded on a network server.

The HP EWS provides an interface to the product that anyone who has a network-connected computer and a standard Web browser can use. No special software is installed or configured, but you must have a supported Web browser on the computer. To gain access to the HP EWS, type the IP address for the product in the address line of the browser.

For a complete explanation of the features and functionality of the HP EWS, see the *HP LaserJet P3010 Series Printers Embedded Web Server User Guide*, which is available on the printing system software CD.

HP Easy Printer Care

HP Easy Printer Care software is a program that you can use for the following tasks:

- Check the product status.
- Check the supplies status and use HP SureSupply to shop online for supplies.
- Set up alerts.
- View product usage reports.
- View product documentation.
- Gain access to troubleshooting and maintenance tools.
- Use HP Proactive Support to routinely scan your printing system and to prevent potential problems. HP Proactive Support can update software, firmware, and HP printer drivers.

You can view HP Easy Printer Care software when the product is directly connected to your computer or when it is connected to a network.

Table 1-2 HP Easy Printer Care support

Supported operating systems	<ul style="list-style-type: none"> • Microsoft® Windows 2000 Service Pack 4 • Microsoft Windows Server 2003 • Microsoft Windows XP, Service Pack 2 Professional or Home • Microsoft Windows Vista™
Supported browsers	<ul style="list-style-type: none"> • Microsoft Internet Explorer 6.0 or 7.0

To download HP Easy Printer Care software, use the HP Easy Printer Care link on the printing system software CD that appears at the end of the driver installation sequence. You can also use your Web browser to go directly to www.hp.com/go/easyprintercare. This Web site provides updated information about supported browsers, a list of HP products that support HP Easy Printer Care software, and the *HP LaserJet P3010 Series User Guide*, which provides more information about using the HP Easy Printer Care software.

Supported operating systems for Macintosh

The product supports the following Macintosh operating systems:

- Mac OS X V10.3.9, V10.4, V10.5, and later

 **NOTE:** For Mac OS X V10.4 and later, PPC and Intel® Core Processor Macs are supported.

Supported printer drivers for Macintosh

The HP installer provides PostScript® Printer Description (PPD) files, Printer Dialog Extensions (PDEs), and the HP Printer Utility for use with Mac OS X and Macintosh computers.

The PPDs, in combination with the Apple PostScript printer drivers, provide access to device features. Use the Apple PostScript printer driver that comes with the computer.

Supported utilities for Macintosh

The following additional software is available for Macintosh for use with the HP LaserJet P3010 Series printer.

HP Printer Utility

Use the HP Printer Utility to set up product features that are not available in the printer driver.

You can use the HP Printer Utility when the product uses a universal serial bus (USB) cable or is connected to a TCP/IP-based network.

Open the HP Printer Utility

Open the HP Printer Utility in Mac OS X V10.3 and V10.4

1. Open the Finder, click **Applications**, click **Utilities**, and then double-click **Printer Setup Utility**.
2. Select the product that you want to configure, and then click **Utility**.

Open the HP Printer Utility in Mac OS X V10.5

- From the **Printer** menu, click **Printer Utility**, or
- From the **Print Queue**, click the **Utility** icon.

HP Printer Utility features

The HP Printer Utility consists of pages that you open by clicking in the **Configuration Settings** list. The following table describes the tasks that you can perform from these pages.

Table 1-3 HP Printer Utility features

Item	Description
Device Information	Allows you to view and print a configuration page.
Supplies Status	Shows the device supplies status and provides links for online supplies ordering.
File Upload	Transfers files from the computer to the device.
Upload Fonts	Transfers font files from the computer to the device.
HP Support	Provides access to technical assistance, online supplies ordering, online registration, and recycling and return information.
Duplex Mode	Turns on the automatic two-sided printing mode.
Economode & Toner Density	Turns on the Economode setting to conserve toner, or adjusts toner density.
Resolution	Changes the resolution settings, including the REt setting.
Trays Configuration	Changes the default tray settings.
Stored Jobs	Manages print jobs that are stored on the device hard disk.
E-mail Alerts	Configures the device to send e-mail notices for certain events.
Network Settings	Changes the device network settings and provides access to the embedded Web server. Provides the ability to turn on or off Bonjour support or change the device service name that is listed on a network.
Protect Direct Ports	Use this setting to disable printing over USB or parallel ports.

Table 1-3 HP Printer Utility features (continued)

Item	Description
Additional Settings	Provides access to the embedded Web server.
Supplies Management	Allows you to select how the printer responds to low or depleted supplies.

Embedded Web Server

The product is equipped with the HP EWS, which provides access to information about product and network activities. For a complete explanation of the features and functionality of the HP EWS, see the *HP LaserJet P3010 Series Printers Embedded Web Server User Guide*, which is available on the printing system software CD.

Software for other operating systems

Table 1-4 Software for other operating systems

Operating System	Software
UNIX®	For HP-UX and Solaris networks, go to www.hp.com/support/go/jetdirectunix_software to install model scripts by using the HP Jetdirect printer installer (HPPI) for UNIX. For the latest model scripts, go to www.hp.com/go/unixmodelscripts .
Linux	For information, go to www.hp.com/go/linuxprinting .

Printer driver support in other operating systems

The product is also supported in the following operating systems:

- Microsoft Windows Terminal Server
- Citrix Terminal Server. For more information, go to the following Web site:
www.hp.com/go/citrixprinting

Alternatively, go to the HP.com Web site and search for “c00213455.”
- Microsoft Windows Cluster Server 8. For more information, go to the following Web site:
www.hp.com/go/windowsclusterserver
- HP OpenVMS. For more information, go to the following Web site:
www.hp.com/go/openvmsprinting
- Tru64 UNIX printing. For more information, go to the following Web site:
www.hp.com/go/tru64unixprinting
- SAP printing. For more information, go to the following Web site:
www.hp.com/go/sap/print
- Jetdirect Printer Server and HP Install Network Printer Wizard (INPW). Available *only* from the following Web site:
www.hp.com/go/inpw_software

Availability

Download the printing-system software from the Web, or order it on a CD from HP fulfillment centers.

 **NOTE:** This STR describes drivers that are shipped with the printing-system software CD. This document does *not* describe any drivers that might be released by support personnel.

- [Software component availability for Windows and Macintosh](#)
- [Printing-system software on the Web](#)
- [In-box printing-system software CD](#)

Software component availability for Windows and Macintosh

The following table lists the availability of printing-system software components for Windows and Macintosh computers.

Table 1-5 Software component availability

Component	Windows	Macintosh
HP DIU (SW installer)	x	
Mac Installer		x
TCP Port Monitor	x	
32-bit PCL6 EVO Discrete	x	
64-bit PCL6 EVO Discrete	x	
32-bit PCL5 UPD (link)	x	
64-bit PCL5 UPD (link)	x	
32 bit PS UPD (link)	x	
64-bit PS UPD (link)	x	
Mac OS 10.3 (or greater) Print Driver		x
Print Dialog Extensions		x
User Guide (CHM)	x	
User Guide (PDF)	x	
SW Install Notes	x	
EWS Guide	x	
Jetdirect Guide	x	
Driver Preconfiguration Support Guide	x	
Fonts	x	
Driver Deployment Utility (DDU)	x	
PDF Wrapper Document Viewing (Adobe Reader)	x	
Web Registration (link)	x	
Supplies (link)	x	

Table 1-5 Software component availability (continued)

Component	Windows	Macintosh
Product Information (link)	x	
HP.com (link)	x	
UPD (link)	x	
HP WJA Install (link)	x	
HP Easy Printer Care Install (link)	x	
CD Browser	x	
DMC config files	x	
User Guide (CHM)	x	
User Guide (PDF)	x	
Job Aids (PDFs: Print, Jams) (link)	x	

 **NOTE:** Fonts are installed on the Mac by using the HP Printer Utility.

Printing-system software on the Web

All software that is contained on the installation CD is also available on the Web.

Web deployment is the preferred method for obtaining the latest software. The HP Web site offers an option for automatic e-mail notification about new software releases. See the HP Proactive support link on the Download Drivers and Software page.

The printing-system software is available for download at the following Web site:

www.hp.com/support/ljp3010

The PCL 5, PCL 6, and PS Universal Print Drivers are available for download at the following Web site:
hp.com/go/upd

In-box printing-system software CD

One CD is included in-box with the product. The printing-system software CD contains the following components:

- Software installer
- Administrator software and documentation
- Installer Customization Wizard
- Links to the HP Universal Print Drivers on the Web
- User guides
- Show Me How content
- Product demonstrations and simulations
- Support information

Each CD has two partitions, one each for Windows and Macintosh computers.

The files in each partition of the printing-system software CD include documentation files and files that are required to install and uninstall the printing-system software components.

Printing-system software CD

The root directory in the Windows partition of the printing-system software CD contains the AUTORUN.EXE file, the SETUP.EXE file, support files, and the following directories:

- Autorun
- Driver Deployment Utility
- Drivers
- Fonts
- HPSU
- Manuals
- Port Monitor
- Shop for HP Supplies
- Temp

To view the files, insert the printing-system software CD into the CD-ROM drive, right-click **Start**, click **Explore**, and then select the CD-ROM drive.

CD Versions

The printing-system software CD is available in three regional versions and contains the printing-system software in all supported languages as follows:

CD 1 – Americas & Western Europe

- CA = Catalan (Català)
- DA = Danish (Dansk)
- DE = German (Deutsch)
- EN = English
- ES = Spanish (Español)
- ET = Estonian (Eesti)
- FI = Finnish (Suomi)
- FR = French (Français)
- HE = Hebrew
- IT = Italian (Italiano)
- LT = Lithuanian
- LV = Latvian

- NL = Dutch (Nederland)
- NO = Norwegian (Norsk)
- PT = Brazilian Portuguese (Português)
- SV = Swedish (Svenska)

CD 2 – Asia Pacific

- EN = English
- ID = Indonesia (Bahasa)
- JA = Japanese
- KO = Korean
- TH = Thai
- VI = Vietnamese
- ZHCN = Simplified Chinese
- ZHTW = Traditional Chinese

CD 3 – Eastern Europe

- AR = Arabic
- BG = Bulgarian
- CS = Czech (Cesky)
- EL = Greek
- EN = English
- FR = French
- HR = Croatian (Hrvatski)
- HU = Hungarian (Magyar)
- KK = Kazakh
- PL = Polish (Polski)
- RO = Romanian
- RU = Russian (Russ)
- SK = Slovak
- SL = Slovenian
- SR = Serbian
- TR = Turkish (Turkçe)
- UK = Ukrainian

Table 1-6 Supported printing-system components (AR-ET)

Component	AR	BG	CA	CS	DA	DE	EL	EN	ES	ET
Admin CD										
CD Browser	x	x	x	x	x	x	x	x	x	x
Driver Installation Utility (HP DIU)	x	x	x	x	x	x	x	x	x	x
PCL6 Driver	x	x	x	x	x	x	x	x	x	x
Screen Fonts								x		
Driver Deployment Utility (HP DDU)	x	x	x	x	x	x	x	x	x	x
Driver Configuration Editor (DMC)	x	x	x	x	x	x	x	x	x	x
Install Notes (HTML)	x		x	x	x	x	x	x	x	
HP Driver Preconfiguration Guide (PDF)	x			x	x	x	x	x	x	
Embedded Web Server Guide (PDF)				x	x	x		x	x	
Jetdirect Admin Guide (CHM, PDF)				x	x	x		x	x	
Printer Driver (Mac)					x	x		x	x	
HP Printer Utility (Mac)					x	x		x	x	
User CD										
Quick Reference Guide				x	x	x		x	x	
User Guide (CHM, PDF)	x		x	x	x	x	x	x	x	
Job Aids								x	x	
Product Demos and Simulations						x		x	x	
Control Panel Wall Poster	x			x	x	x	x	x	x	

Table 1-7 Supported printing-system components (FI-KO)

Component	FI	FR	HE	HR	HU	ID	IT	JA	KK	KO
Admin CD										
CD Browser	x	x	x	x	x	x	x	x	x	x
Driver Installation Utility (HP DIU)	x	x	x	x	x	x	x	x	x	x
PCL6 Driver	x	x	x	x	x	x	x	x	x	x
Screen Fonts										
Driver Deployment Utility (HP DDU)	x	x	x	x	x	x	x	x	x	x

Table 1-7 Supported printing-system components (FI-KO) (continued)

Component	FI	FR	HE	HR	HU	ID	IT	JA	KK	KO
Driver Configuration Editor (DMC)	x	x	x	x	x	x	x	x	x	x
Install Notes (HTML)	x	x	x	x	x	x	x	x		x
HP Driver Preconfiguration Guide (PDF)	x	x	x		x		x	x		x
Embedded Web Server Guide (PDF)	x	x			x		x	x		x
Jetdirect Admin Guide (CHM, PDF)	x	x			x		x	x		x
Printer Driver (Mac)	x	x					x	x		x
HP Printer Utility (Mac)	x	x					x	x		x
User CD										
Quick Reference Guide	x	x			x		x	x		x
User Guide (CHM, PDF)	x	x	x	x	x	x	x	x		x
Job Aids		x						x		
Product Demos and Simulations		x					x			
Control Panel Wall Poster	x	x	x	x	x	x	x	x		x

Table 1-8 Supported printing-system components (LT-SL)

Component	LT	LV	NL	NO	PL	PT	RO	RU	SK	SL
Admin CD										
CD Browser	x	x	x	x	x	x	x	x	x	x
Driver Installation Utility (HP DIU)	x	x	x	x	x	x	x	x	x	x
PCL6 Driver	x	x	x	x	x	x	x	x	x	x
Screen Fonts										
Driver Deployment Utility (HP DDU)	x	x	x	x	x	x	x	x	x	x
Driver Configuration Editor (DMC)	x	x	x	x	x	x	x	x	x	x
Install Notes (HTML)			x	x	x	x	x	x	x	x
HP Driver Preconfiguration Guide (PDF)			x	x	x	x		x		
Embedded Web Server Guide (PDF)			x	x	x	x		x		
Jetdirect Admin Guide (CHM, PDF)			x	x	x	x		x		
Printer Driver (Mac)			x	x		x		x		

Table 1-8 Supported printing-system components (LT-SL) (continued)

Component	LT	LV	NL	NO	PL	PT	RO	RU	SK	SL
HP Printer Utility (Mac)			x	x		x		x		
User CD										
Quick Reference Guide			x	x	x	x		x		
User Guide (CHM, PDF)			x	x	x	x	x	x	x	x
Job Aids										
Product Demos and Simulations										
Control Panel Wall Poster			x	x	x	x	x	x	x	x

Table 1-9 Supported printing-system components (SR-ZHT)

Component	SR	SV	TH	TR	UK	VI	ZHC	ZHT
Admin CD								
CD Browser	x	x	x	x	x	x	x	x
Driver Installation Utility (HP DIU)	x	x	x	x	x	x	x	x
PCL6 Driver	x	x	x	x	x	x	x	x
Screen Fonts								
Driver Deployment Utility (HP DDU)	x	x	x	x	x	x	x	x
Driver Configuration Editor (DMC)	x	x	x	x	x	x	x	x
Install Notes (HTML)		x	x	x			x	x
HP Driver Preconfiguration Guide (PDF)		x	x	x			x	x
Embedded Web Server Guide (PDF)		x	x				x	x
Jetdirect Admin Guide (CHM, PDF)		x		x			x	x
Printer Driver (Mac)		x					x	x
HP Printer Utility (Mac)		x					x	x
User CD								
Quick Reference Guide		x		x			x	x
User Guide (CHM, PDF)		x	x	x			x	x
Job Aids								
Product Demos and Simulations								
Control Panel Wall Poster		x	x	x			x	x

Documentation availability and localization

The printing-system software CD that is included with the product contains documentation.

Access to the documents depends on the document type and location as follows:

- Some documents can be opened from the CD Browser.
- Some documents appear on the CD and can *only* be opened by navigating to the folder where they reside.
- Some documents are available on the Web through links in the CD Browser or CD folders.

Documents are available in the following file formats:

- **Portable document format (.PDF)**. To view documentation in .PDF format, Adobe® Acrobat® Reader must be installed on the computer. Adobe Acrobat Reader is available at the following Web site:
www.adobe.com
- **Compiled HTML (.CHM)**. When you click a documentation link to a .CHM document, a Microsoft HTML Viewer opens the file on the computer screen.
- **Hypertext markup (.HTM)**. When you click a documentation link to an .HTM document, a Web browser opens the file on the computer screen.

Printing-system software CD

- [Main browser screen](#)
- [Administrator Documentation](#)
- [User Documentation](#)
- [Support](#)

Main browser screen

To view documentation on the printing-system software CD, insert the CD into the CD-ROM drive. The main screen of the CD Browser opens. Move the cursor over each option to see a description of the option in the right panel.

Figure 1-1 Printing-system software CD – main browser screen



Administrator Documentation

On the main screen of the printing-system software CD Browser, click **Advanced Install Options**, and then click **Administrator Documentation** to open the **Administrator Documentation** screen. Move the cursor over each option to see a description of the option in the right panel.

Figure 1-2 Administrator Documentation screen



- [HP Embedded Web Server User Guide](#)
- [HP Jetdirect Administrator's Guide](#)
- [HP Driver Preconfiguration Support Guide](#)

HP Embedded Web Server User Guide

The *HP LaserJet P3010 Series Printers Embedded Web Server User Guide* provides information about gaining access to product status, settings, and networking through the HP EWS.

Use the link on the printing-system software CD Browser to download the guide from the product support Web pages. Follow these steps:

1. On the main screen of the CD Browser, click **Advanced Installation Options**.
2. Click **Administrator Documentation**.
3. Click **Embedded Web Server Guide**.
4. Your Web browser launches and opens to the product support Web site at www.hp.com/support/ljp3010.
5. Use the links on this page to download the guide to your computer.

HP Jetdirect Administrator's Guide

The *HP Jetdirect Administrator's Guide* is a network administrator guide that contains information about connecting the product directly to a network.

Open this guide from the printing-system software CD Browser as follows:

1. On the main screen of the printing-system software CD Browser, click **Advanced Installation Options**.
2. Click **Administrator Documentation**.
3. Click **HP Jetdirect Guide**.

Open the guide from the CD directory as follows:

1. Insert the printing-system software CD into the CD-ROM drive.
2. Navigate to the **Manuals\<language>** folder.
3. Open the following file:

HPJDIAG_XXWW.PDF

 **NOTE:** For information about which languages are supported, see Tables 8-11 in this chapter.

NOTE: The "XX" in the file name corresponds to the language. For French, the file name is HPJDIAG_FRWW.PDF.

When the file is open, click **File** and then click **Save As...** to save a copy of the file to another location.

The guide can also be accessed as an MS Windows Help file (.CHM file). This readable, onscreen version of the guide is provided in accordance with the Americans with Disabilities Act (ADA).

Open the .CHM from the CD directory as follows:

1. Insert the printing-system software CD into the CD-ROM drive.
2. Navigate to the **Manuals\<language>** folder.
3. Open the following file:

HPJDIAG_XXWW.CHM

 **NOTE:** For information about which languages are supported, see Tables 8-11 in this chapter.

NOTE: The "XX" in the file name corresponds to the language. For French, the file name is HPJDIAG__FRWW.CHM.

HP Driver Preconfiguration Support Guide

The *HP Driver Preconfiguration Support Guide* (.PDF) contains important information about preconfiguring printer drivers before installation in network environments.

Open this guide from the printing-system software CD Browser as follows:

1. On the main screen of the Admin CD Browser, click **Advanced Installation Options**.
2. Click **Administrator Documentation**.
3. Click **HP Preconfiguration User Guide**.

Open the guide from the printing-system software CD directory as follows:

1. Insert the printing-system software CD into the CD-ROM drive.
2. Navigate to the **MANUALS\<language>** folder.
3. Open the following file: PRECONFIG_SUPPORT_XXWW.PDF

 **NOTE:** For information about which languages are supported, see Tables 8-11 in this chapter.

NOTE: The "XX" in the file name corresponds to the language. For French, the file name is PRECONFIG_SUPPORT_FRWW.PDF.

4. When the file is open, click **File**, and then click **Save As...** to save a copy of the file to another location.

User Documentation

On the main screen of the printing-system software CD Browser, click **User Documentation** to open the **User Documentation** screen. Move the cursor over each option to see a description of the option in the right panel.

Figure 1-3 User Documentation screen



- [User Guide](#)
- [HP LaserJet P3010 Series Printing-System Install Notes](#)

User Guide

The *HP LaserJet P3010 Series User Guide* (in .CHM and .PDF formats) describes basic product features.

Open the .CHM version of the guide from the printing-system software CD Browser as follows:

1. On the main screen of the printing-system software CD Browser, click **User Documentation**.
2. Click **User Guide (Interactive)**.

The guide opens as a Windows Help file (.CHM file). This readable, onscreen version of the guide is provided in accordance with the Americans with Disabilities Act (ADA).

Open the .CHM file from the printing-system software CD directory as follows:

1. Insert the printing-system software CD into the CD-ROM drive.
2. Navigate to the **MANUALS\<language>** folder.
3. Open the following file:

LJP3010_USE_XXWW.CHM

 **NOTE:** For information about which languages are supported, see Tables 8-11 in this chapter.

NOTE: The "XX" in the file name corresponds to the language. For French, the file name is LJP3010_USE_FRWW.CHM.

The *HP LaserJet P3010 Series User Guide* is also provided as a printable .PDF file. Open the .PDF from the printing-system software CD Browser as follows:

1. In the printing-system software CD Browser, click **User Documentation**.
2. Click **User Guide (Printer Friendly)**. The guide opens.
3. Print the guide.

Open the .PDF file from the printing-system software CD directory as follows:

1. Insert the printing-system software CD into the CD-ROM drive.
2. Navigate to the **MANUALS\<language>** folder.
3. Open the following file:

LJP3010_USE_XXWW.PDF

 **NOTE:** For information about which languages are supported, see Tables 8-11 in this chapter.

NOTE: The "XX" in the file name corresponds to the language. For French, the file name is LJP3010_USE_FRWW.PDF.

4. When the file is open, click **File**, and then click **Save As...** to save a copy of the file to another location.

HP LaserJet P3010 Series Printing-System Install Notes

The *HP LaserJet P3010 Series Printing-System Install Notes* (.HTM) contains important information about device features, instructions for installing the printing-system software, and technical assistance.

Open the guide from the printing-system software CD Browser as follows:

1. On the main screen of the CD Browser, click **User Documentation**.
2. Click **Install Notes**.

Open the .HTM file:

1. Insert the printing-system software CD into the CD-ROM drive.
2. Navigate to the **Manuals\<language>** folder.
3. Open the following file:
LJP3010_INSTALL-NOTE_XXWW.HTM

 **NOTE:** For information about which languages are supported, see Tables 8-11 in this chapter.

NOTE: The "XX" in the file name corresponds to the language. For French, the file name is LJP3010_INSTALL-NOTE_FRWW.HTM.

Support

On the main screen of the printing-system software CD Browser, click **Support** to open the **Online Support** screen. Move the cursor over each option to see a description of the option in the right panel.

Figure 1-4 Online Support screen



- Click **Product Registration** to register the product on the hp.com Web site.
- Click the **Supplies** button for information about ordering supplies.
- Click the **Product Information** button to open the HP Instant Support Web page for support information and updates for the product.
- Click the **hp.com** button to visit hp.com and get product support help.

2 Software description

- [Windows printing-system software](#)
- [Windows printer-driver configuration](#)
- [HP Driver Diagnostic Printer Check Tool](#)
- [Embedded Web Server](#)
- [HP Web Jetadmin](#)
- [Font support](#)

Windows printing-system software

- [Supported operating systems for Windows](#)
- [Windows system requirements](#)
- [Macintosh system requirements](#)
- [Printer driver](#)
- [Select the correct printer driver for Windows](#)
- [Priority for print settings](#)
- [Change printer-driver settings for Windows](#)
- [Printing system and installer](#)
- [Driver version numbers for Windows operating systems](#)

Supported operating systems for Windows

The product supports the following Windows operating systems:

- Windows 2000 Service Pack 3
- Windows XP (32-bit and 64-bit)
- Windows Server 2003 (32-bit and 64-bit)
- Windows Vista (32-bit and 64-bit)
- Windows Server 2008 (32-bit and 64-bit)

Windows system requirements

The HP printing-system software has the following minimum system requirements for the following Windows operating systems:

- **Windows 2000 Service Pack 3:** 333-MHz processor with 64 MB RAM
- **Windows XP:** 333-MHz processor with 128 MB RAM
- **Windows Server 2003:** 550-MHz processor with 128 MB RAM
- **Windows Vista:** 800-MHz processor with 512 MB RAM
- **Windows Server 2008:** 1-GHz processor (x86) or 1.4-GHz processor (x64) with 512 MB RAM

All Windows operating systems also have the following requirements:

- A CD-ROM, DVD drive, or Internet connection with which to install the printing-system software
- A dedicated USB 1.1 or USB 2.0 connectivity port, or network connection, to communicate with the product

Macintosh system requirements

The HP printing-system software has the following minimum system requirements for the Mac OS X V10.3.9, V10.4, V10.5, and later operating systems:

- CD-ROM
- 128 MB RAM
- 160 MB of free hard disk space

 **NOTE:** For Mac OS V10.4 and later, PPC and Intel Core Processor Macs are supported.

Printer driver

Printer drivers provide access to product features, such as printing on custom-sized paper, resizing documents, and inserting watermarks.

 **NOTE:** The most recent drivers are available at www.hp.com/support/ljp3010.

Select the correct printer driver for Windows

Printer drivers provide access to the product features and allow the computer to communicate with the product (by using a printer language). Check the installation notes and readme files on the product CD for additional software and languages.

HP PCL 6 Printer Driver description

- Recommended for printing in all Windows environments
- Provides the overall best speed, print quality, and product-feature support for most users
- Developed to align with the Windows Graphic Device Interface (GDI) for the best speed in Windows environments
- Might not be fully compatible with third-party and custom software programs that are based on PCL 5

HP PostScript level 3 emulation universal printer driver description

- Recommended for printing with Adobe® software programs or with other highly graphics-intensive software programs
- Provides support for printing from postscript level 3 emulation needs or for postscript flash font support
- Performs slightly faster than the HP PCL 6 Printer Driver driver when using Adobe software programs
- Best print compatibility between Apple Macintosh and Windows applications.

HP PCL 5 Universal Print Driver description

- Recommended for general office printing in Windows environments
- Compatible with previous PCL versions and older HP LaserJet products

- The best choice for printing from third-party or custom software programs
- The best choice when operating with mixed environments, which require the product to be set to PCL 5 (UNIX, Linux, mainframe)

Priority for print settings

Changes to print settings are prioritized depending on where the changes are made.

 **NOTE:** The names of commands and dialog boxes might vary depending on your software program.

- **Page Setup dialog box:** Click **Page Setup** or a similar command on the **File** menu of the program you are working in to open this dialog box. Settings changed here override settings changed anywhere else.
- **Print dialog box:** Click **Print**, **Print Setup**, or a similar command on the **File** menu of the program you are working in to open this dialog box. Settings changed in the **Print** dialog box have a lower priority and do *not* override changes made in the **Page Setup** dialog box.
- **Printer Properties dialog box (printer driver):** Click **Properties** in the **Print** dialog box to open the printer driver. Settings changed in the **Printer Properties** dialog box do not override settings anywhere else in the printing software.
- **Default printer driver settings:** The default printer driver settings determine the settings used in all print jobs, *unless* settings are changed in the **Page Setup**, **Print** or **Printer Properties** dialog boxes.
- **Printer control-panel settings:** Settings changed at the printer control panel have a lower priority than changes made anywhere else.

Change printer-driver settings for Windows

Table 2-1 Change printer-driver settings for Windows

Change the settings for all print jobs until the software program is closed	Change the default settings for all print jobs	Change the product configuration settings
<ol style="list-style-type: none"> 1. On the File menu in the software program, click Print. 2. Select the driver, and then click Properties or Preferences. 	<ol style="list-style-type: none"> 1. Windows XP and Windows Server 2003 (using the default Start menu view): Click Start, and then click Printers and Faxes. <p>-or-</p> <p>Windows 2000 Service Pack 3, Windows XP, and Windows Server 2003 (using the Classic Start menu view): Click Start, click Settings, and then click Printers.</p> <p>-or-</p> <p>Windows Vista: Click Start, click Control Panel, and then in the category for Hardware and Sound, click Printers.</p> <p>-or-</p> <p>Windows Server 2008: Click Start, click Control Panel, and then open the Printers folder.</p> <ol style="list-style-type: none"> 2. Right-click the driver icon, and then select Printing Preferences. 	<ol style="list-style-type: none"> 1. Windows XP and Windows Server 2003 (using the default Start menu view): Click Start, and then click Printers and Faxes. <p>-or-</p> <p>Windows 2000 Service Pack 3, Windows XP, and Windows Server 2003 (using the Classic Start menu view): Click Start, click Settings, and then click Printers.</p> <p>-or-</p> <p>Windows Vista: Click Start, click Control Panel, and then in the category for Hardware and Sound click Printer.</p> <ol style="list-style-type: none"> 2. Right-click the driver icon, and then select Properties. 3. Click the Device Settings tab.
<p>The steps can vary; this procedure is most common.</p>		

Printing system and installer

- [Printing-system software CD for Windows systems](#)
- [Installer features](#)

Printing-system software CD for Windows systems

In supported Windows operating systems, insert the printing-system CD in the CD-ROM drive to open an interactive CD Browser. Use the CD Browser to install the drivers and related components and to gain access to online user documentation, a customization utility, and optional HP software.

Figure 2-1 Installation software CD Browser

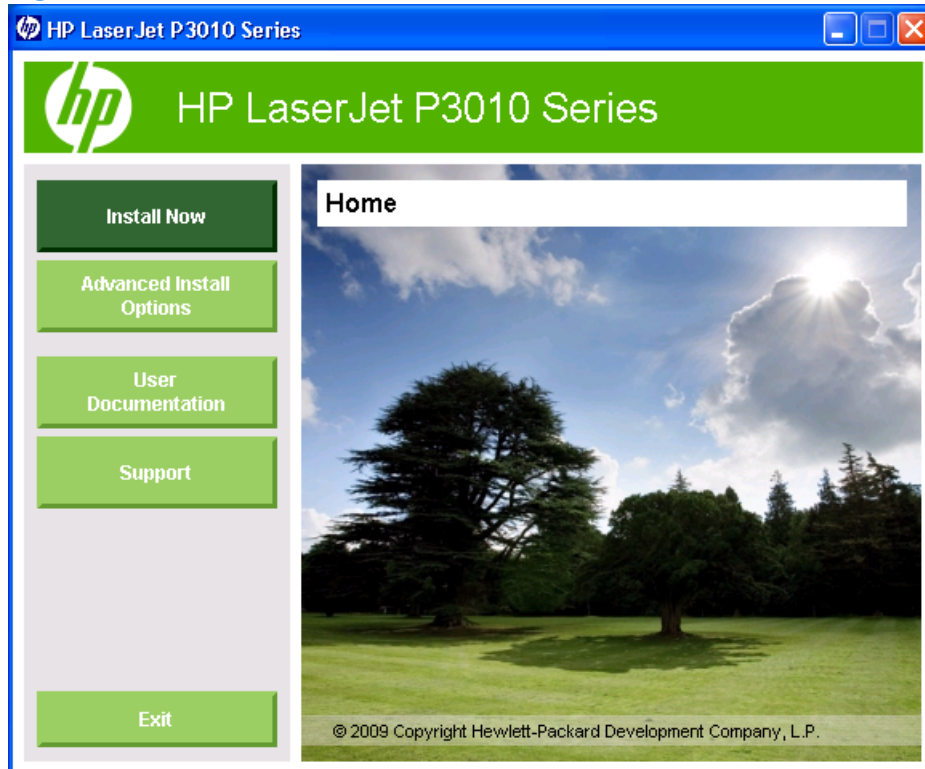

If the screen does not appear when you insert the printing-system CD into the CD-ROM drive, follow these steps to open the CD Browser:

1. Click **Start**.
2. Click **Run**.
3. Click **Browse...** and navigate to the root directory of the software CD.
4. Double-click the SETUP.EXE file to start the installer.

The main screen of the CD Browser contains installation and documentation options in the left panel. Move the cursor over each option to see a description of the option in the right panel.

 **NOTE:** The options available for each product might differ from those in the figure.

Install Now. Opens the HP Driver Installation Utility (DIU). The DIU installs the HP PCL 6 Printer Driver, the recommended driver, and screen fonts. To install additional drivers, click **Advanced Install Options**, and then click **Install PS Driver** to install the product version of the PS Universal Print Driver.

Or click **Administrator Software**, and then click **HP Universal Print Driver** to download and install the HP PCL 6 , PCL 5, or PS Universal Print Driver via the Web.

Advanced Install Options. Provides options for installing other software.

Figure 2-2 Advanced Installation Options



- Click **Install PCL 6 Driver** to install the HP PCL 6 Printer Driver.
- Click **Install PS Driver** to install the HP PS Emulation Universal Printer Driver from hp.com. You can also install the PCL 5 Universal Print Driver from this location.
- Click **Install Documentation and Optional Software** to install screen fonts and the product user guide..

Administrator Software. This option provides the following links to administrator software programs for the product.

Figure 2-3 Administrator Software screen

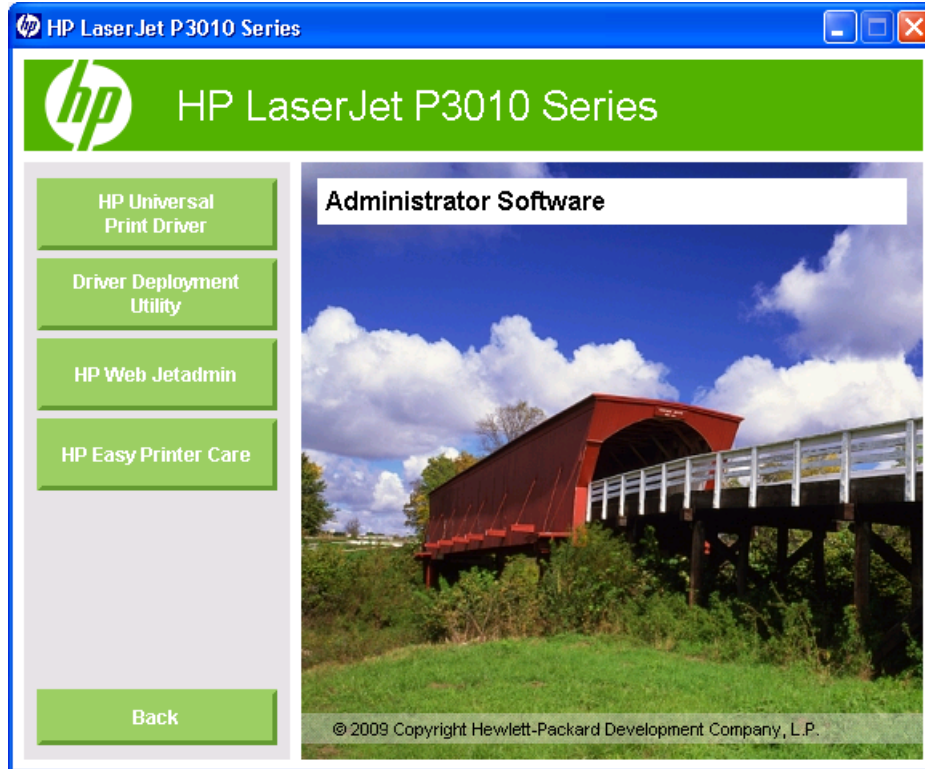

- **HP Universal Print Driver Portal.** Use this option to download the HP PCL 6, PCL 5, or PS Universal Printer Driver from the HP Web site. This printer driver ensures a standard interface to find and print to an HP product.
- **Driver Deployment Utility.** Use this option to start the HP Driver Deployment Utility, used to create a driver install package for silent/unattended installations.
- **HP Web Jetadmin.** Use this option to download HP Web Jetadmin software, a network print management tool, from the HP Web site.
- **HP Easy Printer Care.** Use this option to download and install HP Easy Printer Care. This maintenance tool helps track and maintain multiple products by providing information about status, alert notifications, usage, and supplies.

Administrator Documentation. Use this option to view the administrator documentation. The following document options are available:

Figure 2-4 Administrator Documentation screen

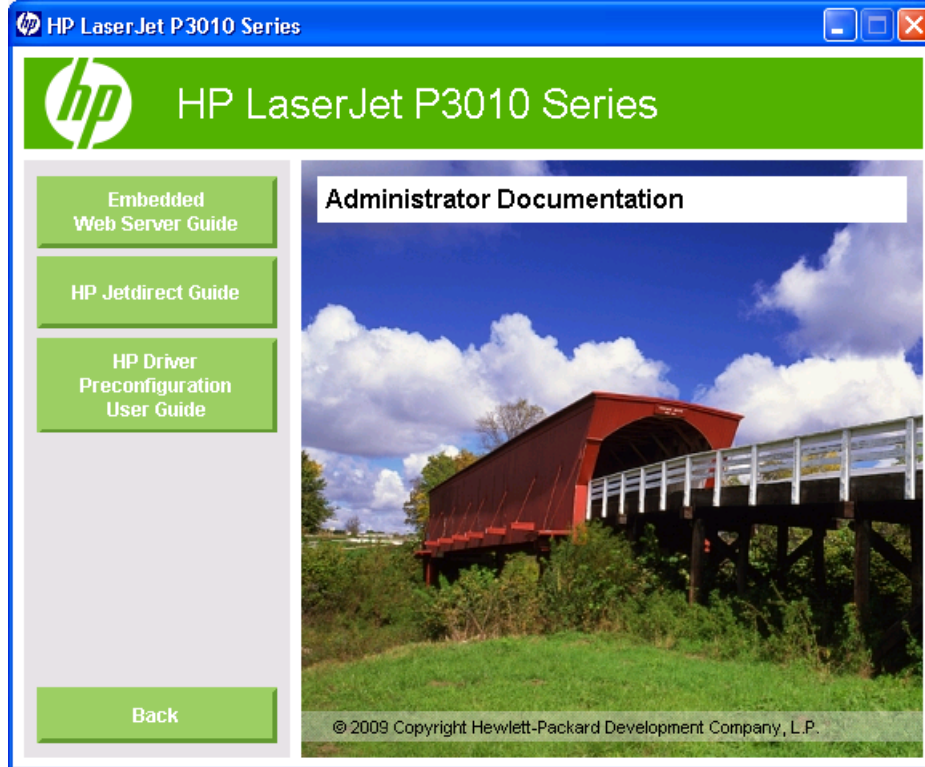

- **Embedded Web Server Guide**
- **HP Jetdirect Guide**
- **HP Driver Preconfiguration User Guide**

Support. This option provides the following links to support information:

Figure 2-5 Online Support screen



- Click **Product Registration** to register the product online.
- Click **Supplies** for information about ordering supplies.
- Click **Product Information** to open the HP Instant Support Web page for support information and updates for the product.
- Click **hp.com** to go to the HP home Web page for information about products and services, support, drivers, and HP online stores.

Click **Back** to return to the main CD Browser screen.

 **NOTE:** To view documentation in .PDF format, Adobe® Acrobat® Reader must be installed on the computer. Adobe Acrobat Reader is available at the following Web site:

<http://www.adobe.com>

Installer features

The HP Driver Installation Utility (HP-DIU) installer is designed to provide a simple and consistent installation method for the printing-system software in supported Windows operating systems.

The HP-DIU installer offers the following features:

- The Administrator software CD features an interactive software interface.
- Network connection is integrated so that you can install drivers and connect to a networked product in a single process.
- The selection dialog box sets the operating-system language as the default language. You can use the installer to select any of the languages on the Admin CD.

All of the printing-system components are installed by using the HP-DIU installer. The installer automatically detects the language of choice and the operating system.

Driver version numbers for Windows operating systems

Access to driver version numbers varies, depending on the operating system in which the printing system is installed.

 **NOTE:** For a list of product drivers, updated HP printing-system software, and product-support information, go to:

www.hp.com/support/ljp3010

In supported Windows operating systems, follow these steps to find driver-version information:

1. Click **Start**, and then do one of the following:

Windows 2000: Select **Settings**, and then click **Printers**.

-or-

Windows XP: Click **Control Panel**, and then double-click the **Printers and Other Hardware** icon.

-or-

Windows Server 2003 and Windows XP Professional: Select **Settings**, and then select **Printers and Faxes**.

-or-

Windows Vista: Click **Control Panel**, click **Hardware and Sound**, and then click **Printers**.

-or-

Windows Server 2008: Click **Start**, click **Control Panel**, and then open the **Printers** folder.

2. Right-click the product driver icon.
3. Click **Properties**.
4. Click the **About** tab.

To determine the latest version, compare the overall build number (in parentheses after the model name) and the HPXXXXXX.GPD version number (in the **Driver Files:** field). If the overall build number has increased, this is the latest version of the driver.

If the overall build number is the same, check the version number of the GPD file. The driver that has the highest GPD version number is the latest driver.

Windows printer-driver configuration

The HP PCL 6 printer driver features bidirectional communication technology which, in environments that support the printer driver, provides automatic discovery and printer-driver configuration for product accessories at the time of installation.

Some accessories that are automatically discovered and configured include the duplexing unit, optional paper trays, and dual inline memory modules (DIMMs).

- [Printer-driver autoconfiguration](#)
- [Bidirectional communication](#)
- [Enterprise AutoConfiguration](#)
- [Update Now](#)
- [HP Web Jetadmin](#)

Printer-driver autoconfiguration

 **NOTE:** The 64-bit operating systems do not support printer-driver autoconfiguration.

Automatic discovery and printer-driver configuration through bidirectional communication occurs in the following circumstances:

- When a printer driver is installed by using Enterprise AutoConfiguration (EAC)
- When the **Update Now** feature is used for a printer driver that is already installed

However, as shown in the following table, printer-driver auto configuration and EAC are *not* available in 32-bit Windows operating systems over a direct connection when the printing-system software is installed by using the Add Printer Wizard. Direct connection is a parallel or USB port connection.

Table 2-2 Availability of automatic discovery and printer- driver configuration through bidirectional communication in Windows

Connection type	Add Printer Wizard	HP DIU
Network	Yes	Yes
Direct connection	No	Yes

Bidirectional communication

In environments that support bidirectional communication, the computer communicates with the product during installation, determines the physical configuration, and then configures the printer driver accordingly.

Bidirectional communication is the capability of the product to respond to data inquiries from the computer, such as inquiries regarding the type of print media that is available and the accessories that are connected to the product. Bidirectional communication depends on the network operating system and on the type of connection that exists between the computer and the product. If the connection does not have this capability, the product can accept commands but cannot respond to data inquiries from the host computer.

Enterprise AutoConfiguration

Enterprise AutoConfiguration (EAC) uses bidirectional communication to provide autoconfiguration functionality for installation of the printer driver over a network, whether you use the installer on the Admin CD or the Add Printer Wizard to install the printer driver. Printer-driver installation that includes EAC is configured with the same settings as the physical configuration of the product. Configuration occurs without user interaction.

If bidirectional-communication software has been installed previously, EAC is not activated, and the pre-existing bidirectional-communication software is used to configure the printer driver.

If bidirectional communication software has not been installed, EAC installs bidirectional-communication software that allows it to communicate with the product and automatically match the printer driver with the product configuration. EAC is activated during installation of the printer driver or whenever the **Update Now** feature is used.

If the product configuration changes after installation, the printer driver can be automatically updated by using the **Update Now** feature in environments that support bidirectional communication.

Update Now

If the product configuration changes after installation, the printer driver can be automatically updated by using the **Update Now** feature in environments that support bidirectional communication. For example, if the product is installed and an optional paper-handling accessory is added later, use **Update Now** to query the product and update the printer-driver settings to match the new product configuration.

The **Update Now** feature automatically updates the registry and changes the configuration information that appears on the **Device Settings** tab of the HP PCL 6 printer driver.

To activate **Update Now**, follow these steps:

1. Click **Start**, and then do one of the following:

Windows 2000: Select **Settings**, and then click **Printers**.

-or-

Windows Server 2003 and Windows XP Professional: Select **Settings**, and then select **Printers and Faxes**.

-or-

Windows XP Home: Click **Control Panel**, and then double-click the **Printers and Other Hardware** icon.

-or-

Windows Vista: Click **Control Panel**, click **Hardware and Sound**, and then click **Printers**.

2. Right-click the product name.
3. Click **Properties**.
4. Click **Device Settings**.
5. If necessary, click **Installable Options** to expand it and show the options.

6. In the **Automatic Configuration** drop-down menu, select **Update Now**.
7. Click **OK** to save the setting.

HP Web Jetadmin

HP Web Jetadmin is a software architecture and set of tools for customizing and distributing HP printing-system software in managed corporate printing environments. Using HP Web Jetadmin, information technology (IT) administrators in corporate and enterprise environments can preconfigure the printing and product defaults for HP printer drivers before installing the printer drivers in the network environment.

HP Web Jetadmin is most beneficial when configuring printer drivers for multiple workstations or print servers for print queues that share the same configuration. Two types of features can be configured:

- Product settings
- Printing-preferences settings

HP Web Jetadmin configures the printer driver to match the accessories that are installed on the product, or to match the settings that IT administrators make in the configuration .CFG file (for example, optional trays, total amount of memory, or job-storage settings).

The preconfiguration process consists of three steps:

- Printer-driver acquisition
- Printer-driver preconfiguration
- Printer-driver installation and deployment

These steps can be accomplished in different ways, depending on the tool that is being used to define the configuration.

Printer-driver preconfiguration is supported through four tools. All four are designed with the same basic user-interface (UI) controls for interacting with the .CFG file, but are packaged differently, either to support established product installation workflows or to allow the user to deploy and install the printer driver. The following tools support printer-driver preconfiguration:

- **HP Driver Configuration Editor.** The HP Driver Configuration Editor is a small standalone Windows-based software program that administrators can use to open the .CFG file that is associated with a particular printer driver and make modifications that are applied when that printer driver is installed on the host computer. Use it in environments that have an established process for deploying printer drivers. It is used in the same way as any ordinary Windows-based software program.

The HP Driver Configuration Editor is available at the following Web site:

www.hp.com/support/hpdpc

- **HP Web Jetadmin V10.0.** HP Web Jetadmin can create and edit printer queues in supported Windows operating systems. HP Web Jetadmin customizes printer drivers for the queues. Refer to the *HP Web Jetadmin User Guide* for information on preconfiguring drivers by using HP Web Jetadmin.

HP Web Jetadmin is available at the following Web site:

<http://www.hp.com/go/webjetadmin>

- **Customization Utility.** The Customization Utility enables an IT administrator to preconfigure the printer drivers when customizing the installation for a silent install.

For detailed information about customizing printer drivers with the Customization Utility, see the *HP Driver Preconfiguration Support Guide*, which is available on the Admin CD.

- **HP Driver Deployment Utility.** The HP Driver Deployment Utility (DDU) was created to simplify the deployment of printer drivers onto a client PC. It is a simple utility that packages the driver files, and the code needed to deploy them, into 2 files: an .EXE and a .CAB. These files are run on the client PC to copy the driver files to the Windows driver store, and for network packages, to install the printer. The DDU also allows for preconfiguration of the driver.

For detailed information about using the HP Driver Deployment Utility, see the *HP Driver Preconfiguration Support Guide*, available on the Admin CD.

- [Configurable settings](#)
- [Continuous export](#)

Configurable settings

The following PCL 6 printer-driver features can be preconfigured. Lockable features, which can be locked to prevent end users from changing the setting, have the word **<Lock>** at the end of their respective descriptions.

 **NOTE:** Some selections and options, such as the **Finishing Accessory** option, may depend on the device setting that has been selected.

Printing Preferences tab

- **Print on Both Sides (duplex):** The options are **True** or **False**. **<Lock>**
- **Orientation:** The options are **Portrait**, **Landscape**, **Rotated Portrait**, or **Rotated Landscape**.
- **Print in Grayscale:** The options are **Disabled** or **Enabled**. **<Lock>**
- **Print Quality:** The options are **1200 x 600** or **Image REt 3600**.
- **Paper Size:** See the drop-down list associated with this feature.
- **Media Type:** The options include all of the media types that the product supports. **<Lock>**
- **Services:** The options are either **Disabled** or **Enabled**.
 - **Device Services:** The options are **Disabled** or **Enabled**.
 - Device and Supplies status:** The options are **Disabled** or **Enabled**.
 - **Internet Services:** The options are **Disabled** or **Enabled**.
 - Check for driver updates:** The options are **Disabled** or **Enabled**.
 - Support and troubleshooting:** The options are **Disabled** or **Enabled**.
 - Product manuals:** The options are **Disabled** or **Enabled**.
 - Online diagnostic tools:** The options are **Disabled** or **Enabled**.
 - Show me how:** The options are **Disabled** or **Enabled**.

Shop for Supplies: The options are **Disabled** or **Enabled**.

- **Paper Source:** The options are **Printer Auto Select**, **Manual Feed (Tray 1)**, **Tray 1**, **Tray 2**, or **Tray 3** (if installed, under **Device Settings**).<Lock>

Advanced Features The following advanced features are also available:

- **Pages per Sheet:** The options are **1**, **2**, **4**, **6**, **9**, or **16**.
- **Booklet Printing:** The options are **Off**, **Left Edge Binding**, or **Right Edge Binding**.
- **Send True Type As Bitmap:** The options are **True** or **False**.
- **Print Document On:** The options are **True** or **False**.
- **Scale to Fit:** The options are **True** or **False**.
- **Percent of Normal Size:** The options are **Enter %** or **25-400**.
- **Watermarks:** The options are **None**, **Confidential**, **Draft**, or **Sample**.
- **Copies:** The options are **1** or **(Enter Number)**.
- **PostScript Language Level:** The options are **1**, **2** or **3**.

Device Settings tab

- **Tray 3:** The options are **Installed** or **Not Installed**.
- **Allow Manual Duplexing:** The options are **Enabled** or **Disabled**.
- **Duplex Unit:** The options are **Installed** or **Not Installed**.
- **Mopier Enabled:** The options are **Installed** or **Not Installed**.
- **Printer Hard-Disk:** The options are **Installed** or **Not Installed**.
- **Printer Alert Notification Settings:** The options are **Show for Every Print Job**, **Show for Device Errors and Warnings**, **Show for Device Errors (printing stops)**, or **Disabled**.

This advanced feature also contains the following sub-features:

- **Device Query Interval:** The options are **Normal** or **Minimize Network Traffic**.
- **Access HP Online Product Support:** The drop-down menu options are **Enabled** or **Disabled**.
- **Shop for Supplies:** The options are **Enabled** or **Disabled**.
- **Job Storage:** The options are **Enabled** or **Disabled**.

When a feature is locked, the selected default option is the only option that is available to users. Generally, the feature is unavailable in the printer-driver UI after it has been locked.

Continuous export

The term *continuous export* refers to the ability of the printer driver to copy the latest printer-driver settings to the working copy of the preconfiguration file. Using this feature, the exported values can be transferred when a compatible version of the printer driver is used to upgrade the printer driver. For instance, if the orientation is set to **Landscape** in a printer driver that was originally installed in Windows

2000 Service Pack 3, then the orientation setting automatically remains **Landscape** when the operating system is upgraded to Windows XP or Windows Vista. The continuous export feature functions transparently from the user's perspective and works only between printer drivers of identical models.

 **NOTE:** Not all of the printer-driver components can be exported; however, the exportable components are always the same as the components that can be preconfigured.

HP Driver Diagnostic Printer Check Tool

Use the HP Driver Diagnostic Printer Check Tool, a Web-based diagnostic software program, to determine whether the correct and most current printer driver for the product is in use. Use the following steps to gain access to the HP Driver Diagnostic Printer Check Tool:

1. Open a Web browser.
2. Go to the following Web site:

www.hp.com/go/drivercheck

When the HP Driver Diagnostic Printer Check Tool runs, the products that are currently installed on the computer appear in a list. The tool gathers information about the products, drivers, and system setup in order to diagnose the software driver configuration and check the printer driver.

When the HP Driver Diagnostic Printer Check Tool is open, select the HP product that you want to check. The tool verifies whether the latest printer driver is being used, provides feedback if an incorrect printer driver is being used, and indicates whether an updated printer-driver version is available. Click the latest printer-driver version to download and install it.

The data that the HP Driver Diagnostic Printer Check Tool gathers is stored anonymously so that HP can analyze and continuously improve its diagnostic tools. No private data is gathered from the computer.

Embedded Web Server

The product is equipped with the HP Embedded Web Server (HP EWS), which provides access to information about product and network activities. This information appears in a Web browser, such as Microsoft Internet Explorer, Netscape Navigator, Apple Safari, or Firefox.

The HP EWS resides on the product. It is not loaded on a network server.

The HP EWS provides an interface to the product that anyone who has a network-connected computer and a standard Web browser can use. No special software is installed or configured, but you must have a supported Web browser on the computer. To gain access to the HP EWS, type the IP address for the product in the address line of the browser.

For a complete explanation of the features and functionality of the HP EWS, see the *HP LaserJet P3010 Series Printers Embedded Web Server User Guide*, which is available on the Admin CD.

HP Web Jetadmin

HP Web Jetadmin is a browser-based management tool for HP Jetdirect-connected printers within your intranet, and it should be installed only on the network administrator's computer.

To download a current version of HP Web Jetadmin and for the latest list of supported host systems, visit www.hp.com/go/webjetadmin.

When installed on a host server, a Windows client can gain access to HP Web Jetadmin by using a supported Web browser (such as Microsoft® Internet Explorer 4.x or Netscape Navigator 4.x or later) to navigate to the HP Web Jetadmin host.

Font support

- [Basic Windows fonts](#)
- [Default printing-system fonts](#)

Basic Windows fonts

Supported Windows operating systems includes the following basic fonts, which can be used with any HP product:

- Arial
- Arial Bold
- Arial Bold Italic
- Arial Italic
- Courier New
- Courier New Bold
- Courier New Bold Italic
- Courier New Italic
- Symbol
- Times New Roman
- Times New Roman Bold
- Times New Roman Bold Italic
- Times New Roman Italic
- Wingdings

Default printing-system fonts

The following default fonts are installed with the printing-system software.

Table 2-3 Default fonts

Font name	Font style	File name
Albertus Extra Bold	Regular	ALBR85W.TTF
Albertus Medium	Regular	ALBR55W.TTF
Antique Olive	Regular	OLVR55W.TTF
Antique Olive	Bold	OLVR75W.TTF
Antique Olive	Italic	OLVR56W.TTF
CG Omega	Regular	CGOR45W.TTF
CG Omega	Bold	CGOR65W.TTF
CG Omega	Bold Italic	CGOR66W.TTF

Table 2-3 Default fonts (continued)

Font name	Font style	File name
CG Omega	Italic	CGOR46W.TTF
CG Times	Regular	CGTR45W.TTF
CG Times	Bold	CGTR65W.TTF
CG Times	Bold Italic	CGTR66W.TTF
CG Times	Italic	CGTR46W.TTF
Clarendon Condensed	Bold	CLAR67W.TTF
Coronet	Regular	CORONET.TTF
CourierPS	Regular	CPSR45W.TTF
CourierPS	Bold	CPSR65W.TTF
CourierPS	Bold Oblique	CPSR66W.TTF
CourierPS	Oblique	CPSR46W.TTF
Garamond	Antiqua	GARR45W.TTF
Garamond	Halbfett	GARR65W.TTF
Garamond	Kursiv	GARR46W.TTF
Garamond	Kursiv Halbfett	GARR66W.TTF
Helvetica®	Regular	HEL45W.TTF
Helvetica	Bold	HEL65W.TTF
Helvetica	Bold Oblique	HEL66W.TTF
Helvetica	Oblique	HEL46W.TTF
Helvetica Narrow	Regular	HEL47W.TTF
Helvetica Narrow	Bold	HEL67W.TTF
Helvetica Narrow	Bold Oblique	HEL68W.TTF
Helvetica Narrow	Oblique	HEL48W.TTF
ITC Avant Garde Gothic	Book	AVGR45W.TTF
ITC Avant Garde Gothic	Book Oblique	AVGR46W.TTF
ITC Avant Garde Gothic Demi	Regular	AVGR65W.TTF
ITC Avant Garde Gothic Demi	Oblique	AVGR66W.TTF
ITC Bookman Light	Regular	BOKR35W.TTF
ITC Bookman Light	Italic	BOKR36W.TTF
ITC Bookman Demi	Regular	BOKR75W.TTF
ITC Bookman Demi	Italic	BOKR76W.TTF
ITC Zapf Chancery	Medium Italic	CHANC____.TTF
ITC Zapf Dingbats	Regular	DINGS____.TTF
Letter Gothic	Regular	LETR45W.TTF

Table 2-3 Default fonts (continued)

Font name	Font style	File name
Letter Gothic	Bold	LETR65W.TTF
Letter Gothic	Italic	LETR46W.TTF
Marigold	Regular	MARIGOLD.TTF
New Century Schoolbook	Bold	NCSR75W.TTF
New Century Schoolbook	Bold Italic	NCSR76W.TTF
New Century Schoolbook	Italic	NCSR56W.TTF
New Century Schoolbook	Roman	NCSR55W.TTF
Palatino	Bold	PALR65W.TTF
Palatino	Bold Italic	PALR66W.TTF
Palatino	Italic	PALR46W.TTF
Palatino	Roman	PALR45W.TTF
SymbolPS	Regular	SYMPS__.TTF
Times*	Bold	TIMR65W.TTF
Times	Bold Italic	TIMR66W.TTF
Times	Italic	TIMR46W.TTF
Times	Roman	TIMR45W.TTF
Univers	Bold	UNVR65W.TTF
Univers	Bold Italic	UNVR66W.TTF
Univers	Medium	UNVR55W.TTF
Univers	Medium Italic	UNVR56W.TTF
Univers Condensed	Bold	UNVR67W.TTF
Univers Condensed	Bold Italic	UNVR68W.TTF
Univers Condensed	Medium	UNVR57W.TTF
Univers Condensed	Medium Italic	UNVR58W.TTF

The following additional PS emulation fonts are also available on the CD.

Table 2-4 Additional PS emulation fonts

Font name	Font style	File name
Albertus MT	Regular	PS_12639.TTF
Albertus MT	Italic	PS_12640.TTF
Albertus MT Lt	Regular	PS_14530.TTF
Antique Olive CompactPS	Regular	PS_11120.TTF
Antique Olive Roman	Regular	PS_11119.TTF
Antique Olive Roman	Bold	PS_11118.TTF

Table 2-4 Additional PS emulation fonts (continued)

Font name	Font style	File name
Antique Olive Roman	Italic	PS_11846.TTF
Apple Chancery	Italic	PS_24516.TTF
Bodoni Poster	Regular	PS_12704.TTF
Bodoni PosterCompressed	Regular	PS_14508.TTF
BodoniPS	Regular	PS_12581.TTF
BodoniPS	Bold	PS_12585.TTF
BodoniPS	Bold Italic	PS_12586.TTF
BodoniPS	Italic	PS_12582.TTF
Candid	Regular	PS_24517.TTF
Chicago	Regular	PS_24518.TTF
Clarendon Light	Regular	PS_14513.TTF
ClarendonPS	Regular	PS_10269.TTF
ClarendonPS	Bold	PS_12968.TTF
Cooper Black	Regular	PS_10369.TTF
Cooper Black	Italic	PS_10370.TTF
Copperplate32bc	Regular	PS_14514.TTF
Copperplate33bc	Regular	PS_14515.TTF
CoronetPS	Italic	PS_10249.TTF
Eurostile	Regular	PS_10267.TTF
Eurostile Bold	Regular	PS_10268.TTF
Eurostile ExtendedTwo	Bold	PS_14512.TTF
Eurostile ExtendedTwo	Regular	PS_14511.TTF
Geneva	Regular	PS_24509.TTF
GillSans	Regular	PS_13872.TTF
GillSans	Bold	PS_13874.TTF
GillSans	Bold Italic	PS_13875.TTF
GillSans Condensed	Regular	PS_14053.TTF
GillSans Condensed	Bold	PS_14054.TTF
GillSans ExtraBold	Regular	PS_14051.TTF
GillSans	Italic	PS_13873.TTF
GillSans Light	Italic	PS_13871.TTF
GillSans Light	Regular	PS_13870.TTF
Goudy	Bold	PS_12544.TTF
Goudy	Bold Italic	PS_10695.TTF

Table 2-4 Additional PS emulation fonts (continued)

Font name	Font style	File name
Goudy	Regular	PS_12542.TTF
Goudy ExtraBold	Regular	PS_12545.TTF
Goudy	Italic	PS_12543.TTF
Helvetica Condensed	Regular	PS_14526.TTF
Helvetica Condensed	Bold	PS_14528.TTF
Helvetica Condensed	Bold Italic	PS_14529.TTF
Helvetica Condensed	Italic	PS_14527.TTF
Hoefler Text	Regular	PS_24519.TTF
Hoefler Text Black	Regular	PS_24521.TTF
Hoefler Text Black	Italic	PS_24522.TTF
Hoefler Text	Italic	PS_24520.TTF
Hoefler Text Ornaments	Regular	PS_24523.TTF
Joanna MT	Regular	PS_14503.TTF
Joanna MT	Bold	PS_14505.TTF
Joanna MT	Bold Italic	PS_14506.TTF
Joanna MT	Italic	PS_14504.TTF
Letter Gothic	Italic	PS_13778.TTF
Letter GothicPS	Regular	PS_13777.TTF
Letter GothicPS	Bold	PS_13779.TTF
Letter GothicPS	Bold Italic	PS_13780.TTF
Lubalin Graph	Regular	PS_12675.TTF
Lubalin Graph	Bold	PS_12677.TTF
Lubalin Graph	Bold Italic	PS_12625.TTF
Lubalin Graph	Italic	PS_12623.TTF
MarigoldPS	Regular	PS_94073.TTF
Mona Lisa Recut	Regular	PS_14525.TTF
Monaco	Regular	PS_24524.TTF
New York	Regular	PS_24510.TTF
Optima	Regular	PS_12506.TTF
Optima	Bold	PS_12510.TTF
Optima	Bold Italic	PS_12511.TTF
Optima	Italic	PS_12507.TTF
Oxford	Italic	PS_14072.TTF
StempelGaramond Roman	Italic	PS_11546.TTF

Table 2-4 Additional PS emulation fonts (continued)

Font name	Font style	File name
StempelGaramond Roman	Regular	PS_11545.TTF
StempelGaramond Roman	Bold	PS_11547.TTF
StempelGaramond Roman	Bold Italic	PS_11548.TTF
Taffy	Regular	PS_14507.TTF
Univers 45 Light	Regular	PS_13501.TTF
Univers 45 Light	Bold	PS_14023.TTF
Univers 45 Light	Bold Italic	PS_14024.TTF
Univers 45 Light	Italic	PS_13502.TTF
Univers 47 CondensedLight	Bold	PS_14030.TTF
Univers 47 CondensedLight	Bold Italic	PS_14040.TTF
Univers 55	Regular	PS_14021.TTF
Univers 55	Italic	PS_14022.TTF
Univers 57 Condensed	Regular	PS_14029.TTF
Univers 57 Condensed	Italic	PS_14039.TTF
Univers ExtendedPS	Bold	PS_13548.TTF
Univers ExtendedPS	Regular	PS_13547.TTF
Univers ExtendedPS	Bold Italic	PS_14481.TTF
Univers ExtendedPS	Italic	PS_14480.TTF

3 Install Windows printing-system components

The HP LaserJet P3010 Series comes with software and installers for Microsoft Windows and Apple Macintosh systems. For information about Macintosh software, see [Macintosh software and utilities on page 165](#). Linux and UNIX systems support the HP LaserJet P3010 Series, and software is available on the Web. This chapter provides procedures for installing and uninstalling the HP LaserJet P3010 Series printing-system software for Windows operating systems.

- [Supported operating systems for Windows](#)
- [Windows operating system requirements](#)
- [Install overview](#)
- [Software installation types for Windows](#)
- [Installation options](#)
- [Microsoft Windows general installation overview](#)
- [Detailed MS Windows installation instructions](#)
- [Install documentation and optional software](#)
- [Uninstall software](#)

Supported operating systems for Windows

The HP LaserJet P3010 Series printer supports the following Windows operating systems:

- Windows 2000 Service Pack 3 (32-bit)
- Windows XP (32-bit and 64-bit)
- Windows Server 2003 (32-bit and 64-bit)
- Windows Vista (32-bit and 64-bit)
- Windows Server 2008 (32-bit and 64-bit)

Windows operating system requirements

- **Windows 2000 Service Pack 3:** 333-MHz processor with 64 MB RAM
- **Windows XP:** 333-MHz processor with 128 MB RAM
- **Windows Server 2003:** 550-MHz processor with 128 MB RAM
- **Windows Vista:** 800-MHz processor with 512 MB RAM
- **Windows Server 2008:** 1-GHz processor (x86) or 1.4-GHz processor (x64) with 512 MB RAM

 **NOTE:** All Windows operating systems also require a CD-ROM, DVD drive, or Internet connection to install the HP LaserJet P3010 Series printing-system software, as well as either a dedicated universal serial bus (USB 1.1 or 2.0) connectivity port or network connection to communicate with the printer.

NOTE: Windows 95, Windows 98, Windows Me, and Windows NT are not supported.

Install overview

The software for the HP LaserJet P3010 Series printer is installed from the printing-system software CD. The Setup program installs the HP LaserJet P3010 Series printing-system software from the printing-system software CD onto the hard disk and updates Windows files.

For all supported operating systems, each install option presents a series of screens that guide you through the installation process.

Software installation types for Windows

The HP LaserJet P3010 Series printing-system software can be installed in the following ways:

- **HP Driver Installation Utility (HP DIU):** Recommended, included on the printing-system software CD and from downloaded drivers available at www.hp.com/support/ljp3010.
- Microsoft Add Printer Wizard

Installation options

The HP LaserJet P3010 Series printing-system software can be installed when the product is connected to the computer in the following configurations:

- Directly connected via a USB port
- Connected via the network

Microsoft Windows general installation overview

HP LaserJet P3010 Series printing-system software CD for Windows systems

In supported Windows environments (Windows 2000 Service Pack 3, Windows Server 2003, Windows Server 2008, Windows XP, and Windows Vista), insert the printing-system software CD in the CD-ROM drive to open an interactive CD Browser. Use the CD Browser to install the drivers and related components, and to gain access to online user documentation, a Driver Deployment Utility, and optional HP software.

If the installation screen does not appear when you insert the printing-system software CD into the CD-ROM drive, follow these steps to open the CD Browser:

1. On the **Start** menu, click the **Run** option.
2. Type the following: X:\SETUP.EXE (where X is the letter of the CD-ROM drive).
3. Click the **OK** button.

The main screen of the software CD Browser contains installation and documentation options in the left panel. Move the cursor over each option to see a description of the option in the right panel. The following figure shows the main screen of the HP LaserJet P3010 Series printing-system software CD.

Figure 3-1 CD Browser – Main screen

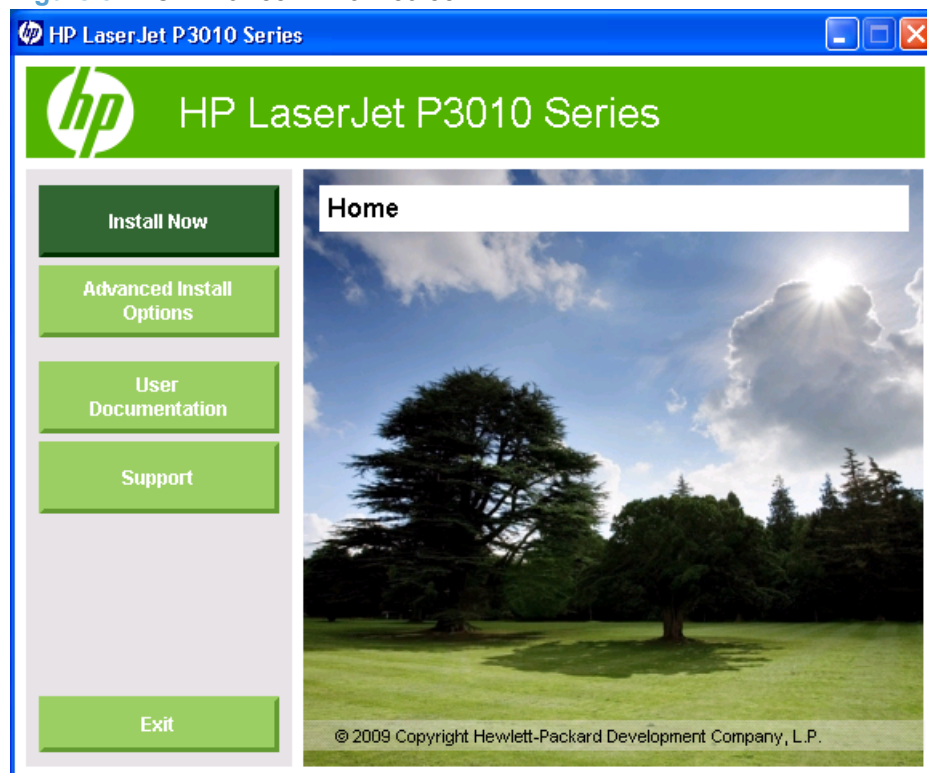

Install Now

 **NOTE:** For detailed installation instructions, see [Detailed MS Windows installation instructions on page 89](#). For a general overview of the installation process, see either [Microsoft Windows installation for direct connections \(Plug and Play\) on page 68](#) or [Microsoft Windows installation for computers on a network on page 81](#).

Click **Install Now** to start the HP Driver Installation Utility (HP DIU). By default, the HP DIU installs the HP PCL6 printer driver, the driver recommended for most users. Screen fonts are also installed.

 **NOTE:** For more information about HP LaserJet P3010 Series printer drivers, see [HP PCL 6 Print Driver for Windows on page 111](#).

Advanced Install Options

Click **Advanced Install Options** to open the **Advanced Installation Options** screen.

Figure 3-2 CD Browser – Advanced Installation Options

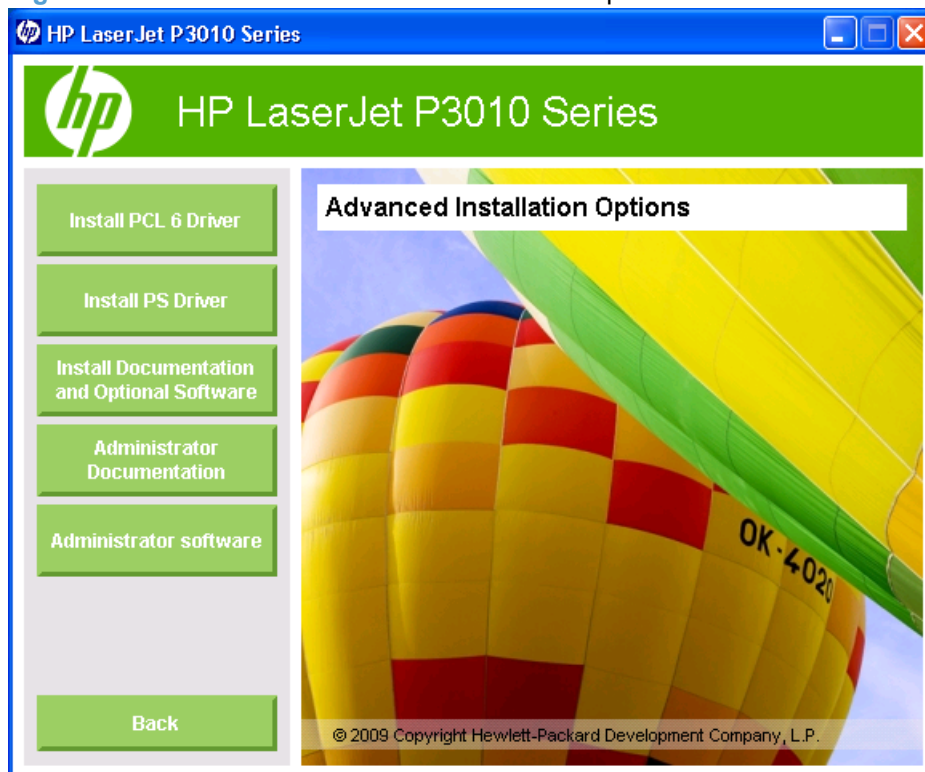

- Click **Install PCL 6 Driver** to install the HP PCL 6 printer driver.
- Click **Install PS Driver** to install a product-specific version of the HP PS Universal Print Driver (includes an installer). A generic version of this driver is also available for download from www.hp.com/go/upd

 **NOTE:** The PCL 5 Universal Print Driver is also available for download from this web site.

- Click **Install Documentation and Optional Software** to install HP LaserJet P3010 Series printer documentation, Screen Fonts, and the HP Supplies software.

- Click **Administrator Documentation** to view or download documentation for the HP Embedded Web Server, the HP Jetdirect print server, and the HP Driver Preconfiguration utility.
- Click **Administrator Software** to view a list of HP LaserJet P3010 Series support tools for network administrators.

Administrator Documentation

Click **Administrator Documentation** to view HP LaserJet P3010 Series support guides for network administrators.

Figure 3-3 CD Browser–Administrator Documentation screen



- Click the **Embedded Web Server Guide** button to view the *HP LaserJet P3010 Series Printers Embedded Web Server User Guide*.
- Click the **HP Jetdirect Guide** button to view network installation and troubleshooting information.
- Click the **HP Driver Preconfiguration User Guide** button to find out how to create and deploy a printer driver with customized settings.

Administrator Software

The following tools are available from the **Administrator Software** screen.

Figure 3-4 CD Browser – Administrator Software screen



- Click **HP Universal Print Driver** for more information and to download a single driver that can be used to print to virtually any HP product. This button provides a Web link to the UPD page on hp.com.
- Click **Driver Deployment Utility** to launch the HP Driver Deployment Utility (DDU). The DDU packages drivers and the code to deploy them onto client PCs. The DDU also supports driver preconfiguration.
- Click **HP Web Jetadmin** for more information and to download a printer management tool designed for network administrators.
- Click **HP Easy Printer Care** for more information and to download a utility to manage up to 15 products.

User Documentation

On the main screen of the printing-system software CD Browser, click **User Documentation** to open the **User Documentation** screen. Move the cursor over each option to see a description of the option in the right panel.

Figure 3-5 User Documentation screen



- [User Guide](#)
- [User Guide](#)
- [HP LaserJet P3010 Series Printing-System Install Notes](#)

User Guide

The *HP LaserJet P3010 Series User Guide* (in .CHM and .PDF formats) describes basic product features.

Open the .CHM version of the guide from the printing-system software CD Browser as follows:

1. On the main screen of the printing-system software CD Browser, click **User Documentation**.
2. Click **User Guide (Interactive)**.

The guide opens as a Windows Help file (.CHM file). This readable, onscreen version of the guide is provided in accordance with the Americans with Disabilities Act (ADA).

Open the .CHM file from the printing-system software CD directory as follows:

1. Insert the printing-system software CD into the CD-ROM drive.
2. Navigate to the **MANUALS\<language>** folder.
3. Open the following file:

LJP3010_USE_XXWW.CHM

 **NOTE:** For information about which languages are supported, see Tables 8-11 in this chapter.

NOTE: The "XX" in the file name corresponds to the language. For French, the file name is LJP3010_USE_FRWW.CHM.

The *HP LaserJet P3010 Series User Guide* is also provided as a printable .PDF file. Open the .PDF from the printing-system software CD Browser as follows:

1. In the printing-system software CD Browser, click **User Documentation**.
2. Click **User Guide (Printer Friendly)**. The guide opens.
3. Print the guide.

Open the .PDF file from the printing-system software CD directory as follows:

1. Insert the printing-system software CD into the CD-ROM drive.
2. Navigate to the **MANUALS\<language>** folder.
3. Open the following file:

LJP3010_USE_XXWW.PDF

 **NOTE:** For information about which languages are supported, see Tables 8-11 in this chapter.

NOTE: The "XX" in the file name corresponds to the language. For French, the file name is LJP3010_USE_FRWW.PDF.

4. When the file is open, click **File**, and then click **Save As...** to save a copy of the file to another location.

User Guide

The *HP LaserJet P3010 Series User Guide* (in .CHM and .PDF formats) describes basic product features.

Open the .CHM version of the guide from the printing-system software CD Browser as follows:

1. On the main screen of the printing-system software CD Browser, click **User Documentation**.
2. Click **User Guide (Interactive)**.

The guide opens as a Windows Help file (.CHM file). This readable, onscreen version of the guide is provided in accordance with the Americans with Disabilities Act (ADA).

Open the .CHM file from the printing-system software CD directory as follows:

1. Insert the printing-system software CD into the CD-ROM drive.
2. Navigate to the **MANUALS\<language>** folder.
3. Open the following file:
LJP3010_USE_XXWW.CHM

 **NOTE:** For information about which languages are supported, see Tables 8-11 in this chapter.

NOTE: The "XX" in the file name corresponds to the language. For French, the file name is LJP3010_USE_FRWW.CHM.

The *HP LaserJet P3010 Series User Guide* is also provided as a printable .PDF file. Open the .PDF from the printing-system software CD Browser as follows:

1. In the printing-system software CD Browser, click **User Documentation**.
2. Click **User Guide (Printer Friendly)**. The guide opens.
3. Print the guide.

Open the .PDF file from the printing-system software CD directory as follows:

1. Insert the printing-system software CD into the CD-ROM drive.
2. Navigate to the **MANUALS\<language>** folder.
3. Open the following file:
LJP3010_USE_XXWW.PDF

 **NOTE:** For information about which languages are supported, see Tables 8-11 in this chapter.

NOTE: The "XX" in the file name corresponds to the language. For French, the file name is LJP3010_USE_FRWW.PDF.

4. When the file is open, click **File**, and then click **Save As...** to save a copy of the file to another location.

HP LaserJet P3010 Series Printing-System Install Notes

The *HP LaserJet P3010 Series Printing-System Install Notes* (.HTM) contains important information about device features, instructions for installing the printing-system software, and technical assistance.

Open the guide from the printing-system software CD Browser as follows:

1. On the main screen of the CD Browser, click **User Documentation**.
2. Click **Install Notes**.

Open the .HTM file:

1. Insert the printing-system software CD into the CD-ROM drive.
2. Navigate to the **Manuals\<language>** folder.
3. Open the following file:

 **NOTE:** For information about which languages are supported, see Tables 8-11 in this chapter.

NOTE: The "XX" in the file name corresponds to the language. For French, the file name is LJP3010_INSTALL-NOTE_FRWW.HTM.

Support

Click **Support** to find support information for the HP LaserJet P3010 Series printer on HP Web sites.

Figure 3-6 CD Browser–Support screen



- Click **Product Registration** to register the product online.
- Click **Supplies** for information about ordering supplies for the product.
- Click **Product Information** to open the HP Instant Support Web page for product support information and updates.
- Click **hp.com** to go to the HP home Web page for information about products and services, support, drivers, and HP online stores.

Additional Options

The **Additional Options** screen appears after you install a printer driver. The following options are available:

Figure 3-7 CD Browser – Additional Options screen

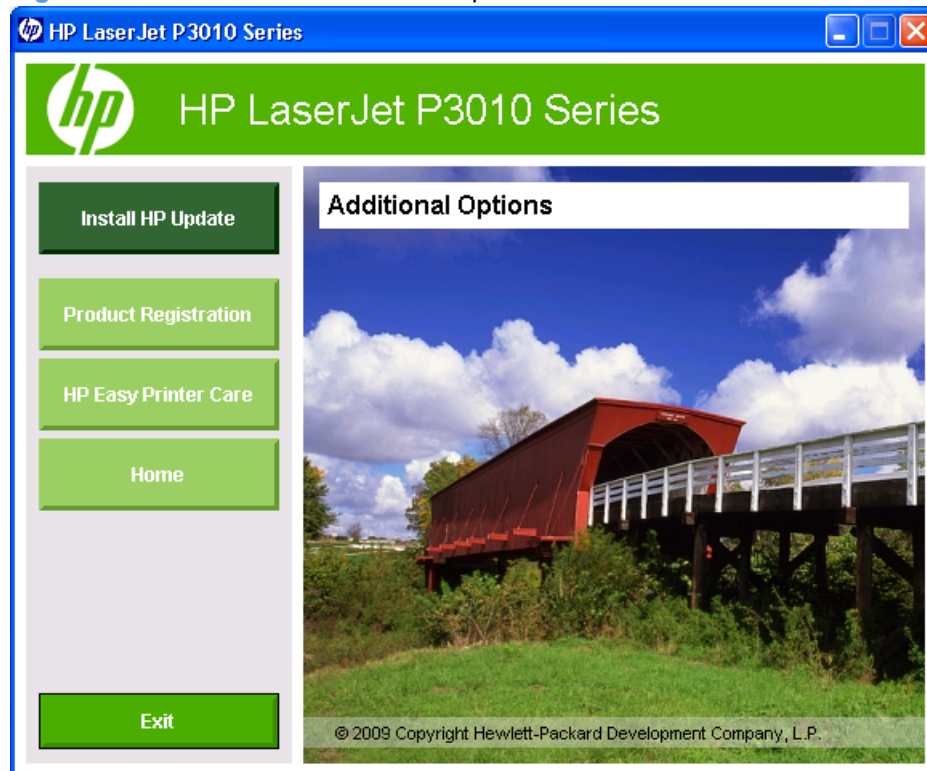

- Click the **Install HP Update** button to install a utility that provides software and driver updates for the product.
- Click the **Product Registration** button to register your product online.
- Click the **HP Easy Printer Care** button for more information and to download a utility to manage up to 15 products.

Microsoft Windows installation for direct connections (Plug and Play)

 **NOTE:** The printing-system software should be installed *before* the HP LaserJet P3010 Series printer is connected to the computer through a USB connection and turned on. During the installation process, the software prompts you to connect the product.

Install from the printing-system software CD

Follow these instructions to install the HP LaserJet P3010 Series printing system software from the CD that came with the product.

1. Quit all software programs.
2. Insert the CD in the CD-ROM drive.

 **NOTE:** If the CD does not start automatically, click **Start**, click **Run**, and then browse to and double-click the SETUP.EXE file in the root directory of the CD.

NOTE: In Windows Vista, you will be prompted to elevate the permissions to administrator in order to complete the installation process.

3. Click **Install Now** and follow the onscreen prompts.

Install the print driver using the Microsoft Add Printer Wizard

 **NOTE:** You can return to the previous screen by clicking the **< Back** button, or exit the Add Printer Wizard by clicking the **Cancel** button.

Select one of the following three options to install the print driver using the Microsoft Add Printer Wizard:

- **Use an existing port for a direct connection:** The product is connected to the computer using a USB cable or is connected via the network without using a print server and the printer port already exists.

Follow these instructions to select the correct connection option:

1. On the **Start** menu, click the **Settings** option, and then perform one of the following:

Windows 2000: Click the **Printers** option.

Windows XP Home: Click the **Printers and Other Hardware Devices** option.

Windows XP Professional, Windows Server 2003, and Windows 2008: Click the **Printers and Faxes** option.

Windows Vista: Under the **Hardware and Sound** category, click the **Printer** option.

2. Click the **Add a printer** option. The Add Printer Wizard opens.
3. Click the **Next** button on the **Add Printer Wizard** welcome dialog box.

4. If the product is connected to the computer using a USB cable or is connected via the network without using a print server, select the **Local printer attached to this computer** option, and then click the **Next >** button.

 **NOTE:** If you select the **Automatically detect an install my Plug and Play printer** check box prior to clicking the **Next >** button, the computer will automatically install the print driver.

NOTE: If the product is connected via the network using a print server, select the **A network printer, or a printer attached to another computer** option (Point and Print installation), and then click the **Next >** button. For detailed installation instructions, see [Print server connection on page 78](#).

Figure 3-8 Add Printer Wizard – Local or Network Printer screen

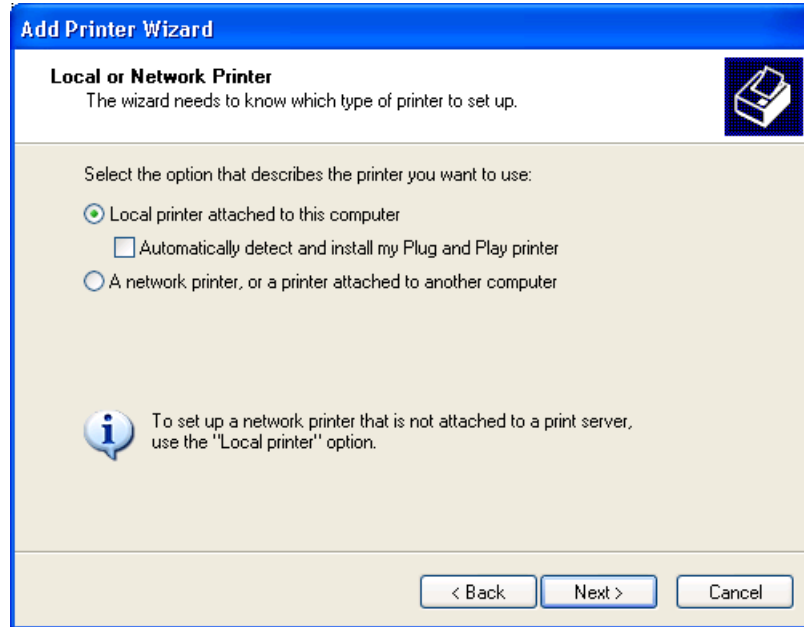

- **Create a new TCP/IP port for a direct connection:** The product is connected via the network without using a print server and the printer port does not exist.
- **Print server connection:** The product is connected via the network using a print server.

Use an existing port for a direct connection

Use these instructions when the product is connected to the computer using a USB cable or when printing via the network without using a print server.

1. If the product is connected to the computer using a USB cable or is connected via the network without using a print server and the printer port already exists, select the **Use the following port** option, select the product name, print path, or IP address of the product from the **Use the following port** drop-down list, and then click the **Next >** button.

 **NOTE:** If the printer port does not appear in the **Use the following port** drop-down list, see [Create a new TCP/IP port for a direct connection on page 75](#). If the product is connected via the network using a print server, see [Print server connection on page 78](#).

Figure 3-9 Add Printer Wizard — Select a Printer Port screen



- (Optional) Click the **Windows Update** button to display a list of drivers that can be downloaded from the Microsoft Windows Update Web site.

If the appropriate model of HP LaserJet P3010 Series is already listed, select it and click the **Next >** button. If the product is not listed, click the **Have Disk** button to continue to the **Install From Disk** screen.

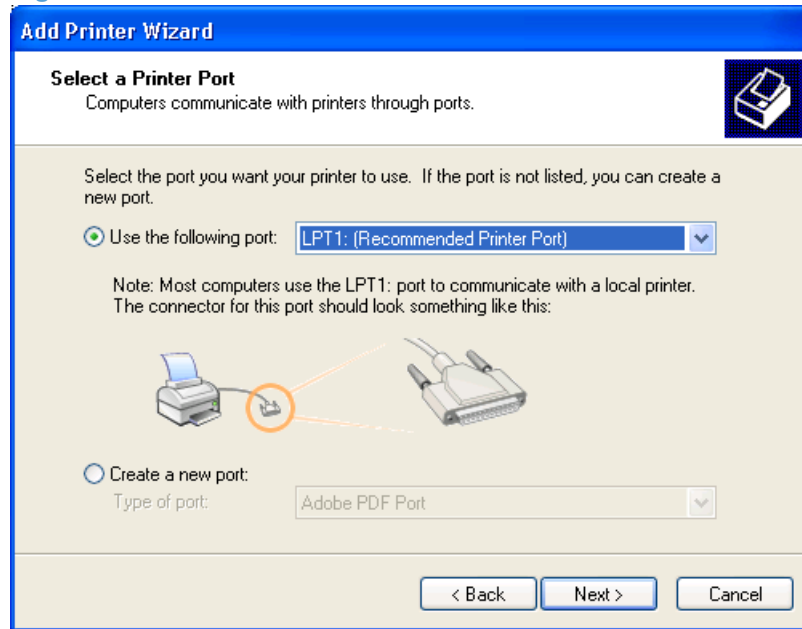
Figure 3-10 Add Printer Wizard — Install Printer Software screen

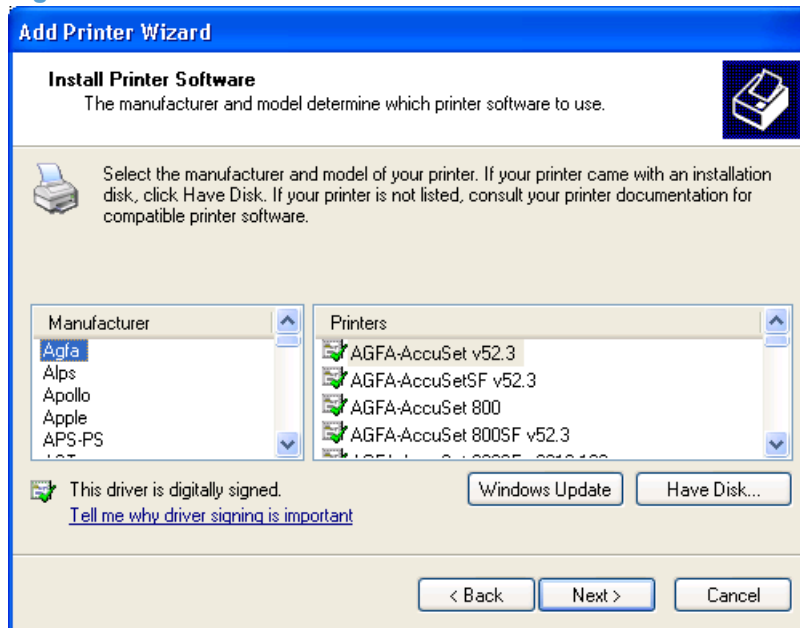

- If the correct path to the CD-ROM drive is listed in the **Copy manufacturer's files from** text box, click the **OK** button. If not, click the **Browse** button to continue to the **Locate File** screen.

Figure 3-11 Add Printer Wizard — Install from Disk screen

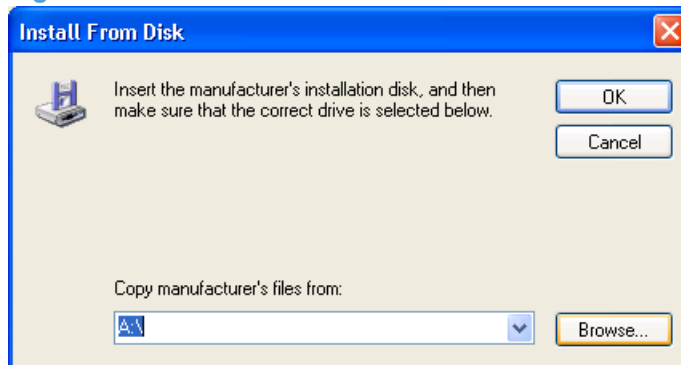

- Navigate to your CD-ROM drive, and then select the .INF file for your product.
- Click the **OK** button to continue to the **Install Printer Software** screen.

6. Select the appropriate model of HP LaserJet P3010 Series from the list and click the **Next >** button to continue to the **Name Your Printer** screen.

Figure 3-12 Add Printer Wizard — Install Printer Software, screen 2

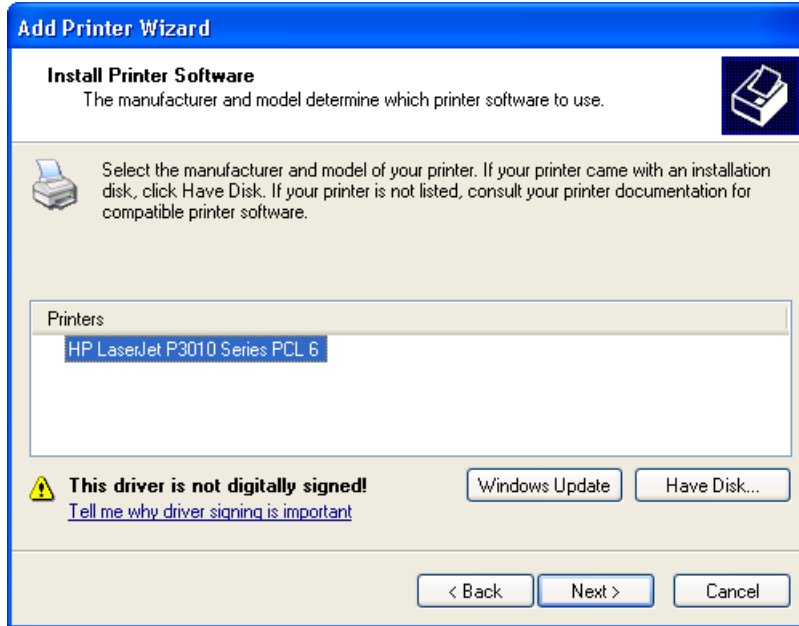

7. You can either type a name for the product in the **Printer name** text box or use the default name provided.

Select the **Yes** option to use this printer as the default printer or select the **No** option to keep the existing product as the default printer.

Click the **Next >** button to continue to the **Printer Sharing** screen.

Figure 3-13 Add Printer Wizard — Name Your Printer screen

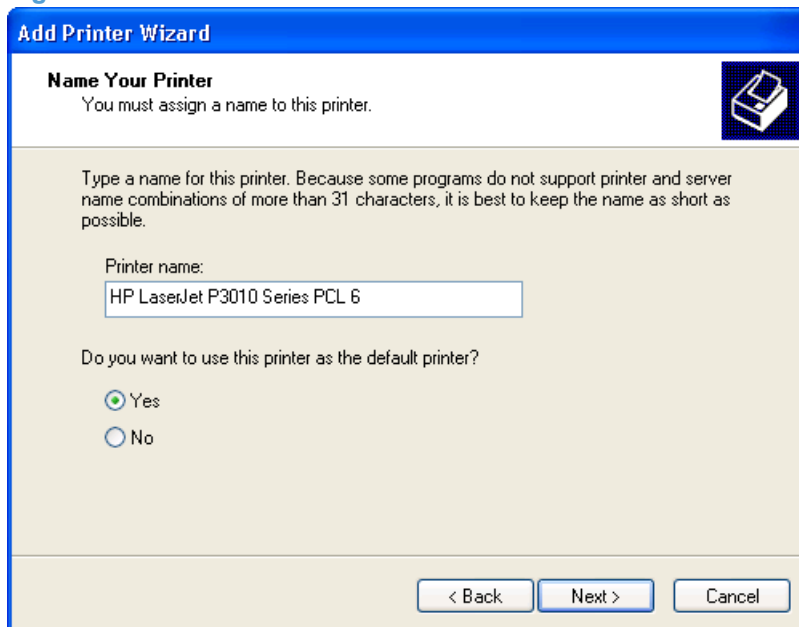

8. Select either the **Do not share this printer** option, or select the **Share name:** option and type share name, and then click the **Next >** button to continue to the **Print Test Page** screen.

 **NOTE:** For more information, see [Point and Print installation for Windows 2000 Service Pack 3, XP, Server 2003, Server 2008, and Vista on page 87.](#)

Figure 3-14 Add Printer Wizard — Printer Sharing screen

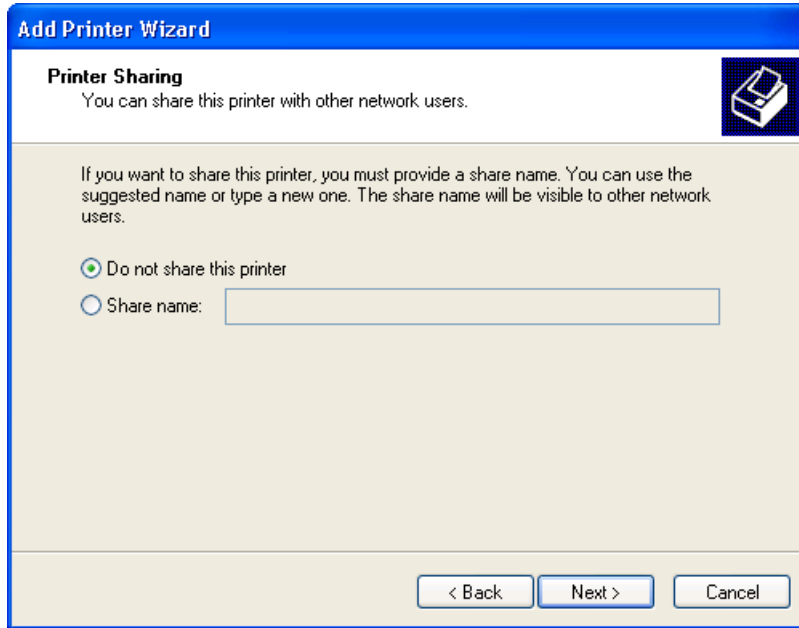

9. Select the **Yes** option if you want to print a test page after the software is installed. Select the **No** option if you do not want to print a test page after the software is installed.

Click the **Next >** button to continue to the **Completing the Add Printer Wizard** screen.

Figure 3-15 Add Printer Wizard — Print Test Page screen

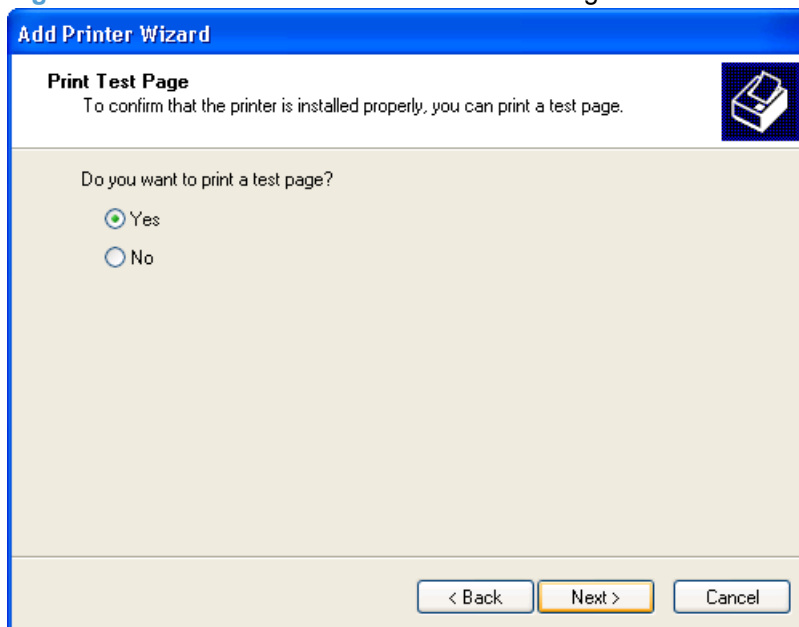

10. Review the installation details, and then click the **Finish** button to complete the Add Printer Wizard.

Create a new TCP/IP port for a direct connection

Perform the following when the product is connected via the network without using a print server and a printer port does not exist:

1. If the printer port does not appear in the **Use the following port** drop-down list, select the **Create a new port** option.
 - If the **HP Standard TCP/IP Port** option appears in the **Type of port** drop-down list, select this option, and then click the **Next** button. The **Welcome to the Add Standard TCP/IP Printer Port Wizard** dialog box appears.
 - If the **HP Standard TCP/IP Port** option does not appear in the **Type of port** drop-down list, select the **Standard TCP/IP Port** option from the **Type of port** drop-down list, and then click the **Next** button. The **Welcome to the Add Standard TCP/IP Printer Port Wizard** dialog box appears.

 **NOTE:** The **HP Standard TCP/IP Port** option provides additional network functionality and is the recommended printer port for HP products.

NOTE: If the printer port already appears in the **Use the following port** drop-down list, see [Use an existing port for a direct connection on page 71](#). If the product is connected via the network using a print server, see [Print server connection on page 78](#).

Figure 3-16 Select a Printer Port screen

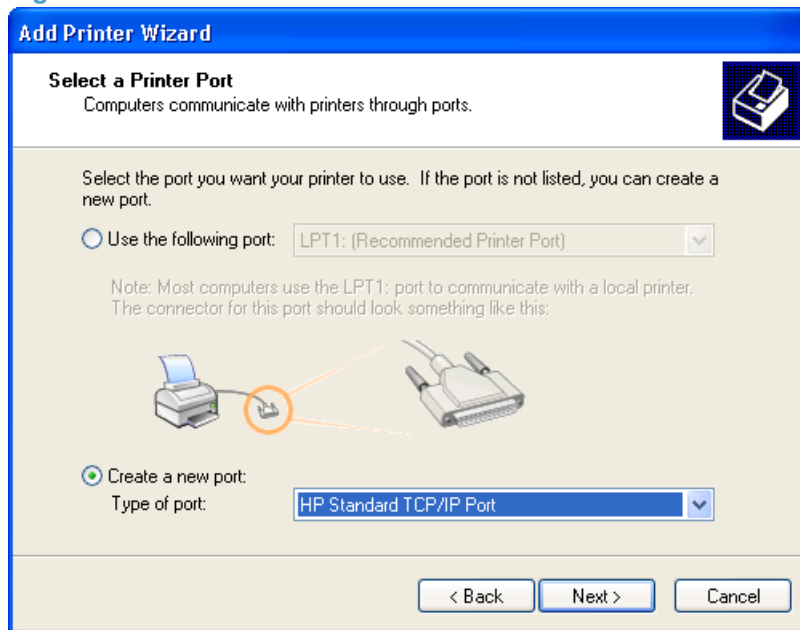

2. Click the **Next >** button.

Figure 3-17 Add Standard TCP/IP Printer Port screen

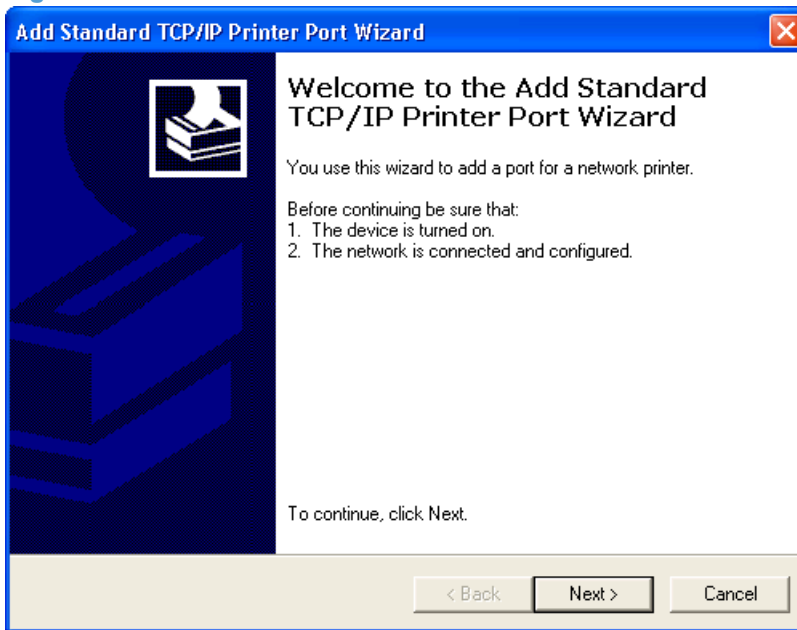

3. Type the product's IP address or host name in the **Printer Name or IP Address** text box, and then click the **Next** button.

 **NOTE:** The default port name is the name that you typed in the **Printer Name or IP Address** text box. You can change this name by typing a new name in the **Port Name** text box.

NOTE: The **Always print to this device, even if its IP address changes** check box is only available if you select the **HP Standard TCP/IP Port** option from the **Select a Printer Port** dialog box. This feature allows the computer to communicate with the product using the MAC address of the network card rather than the IP address.

Figure 3-18 Add Port screen

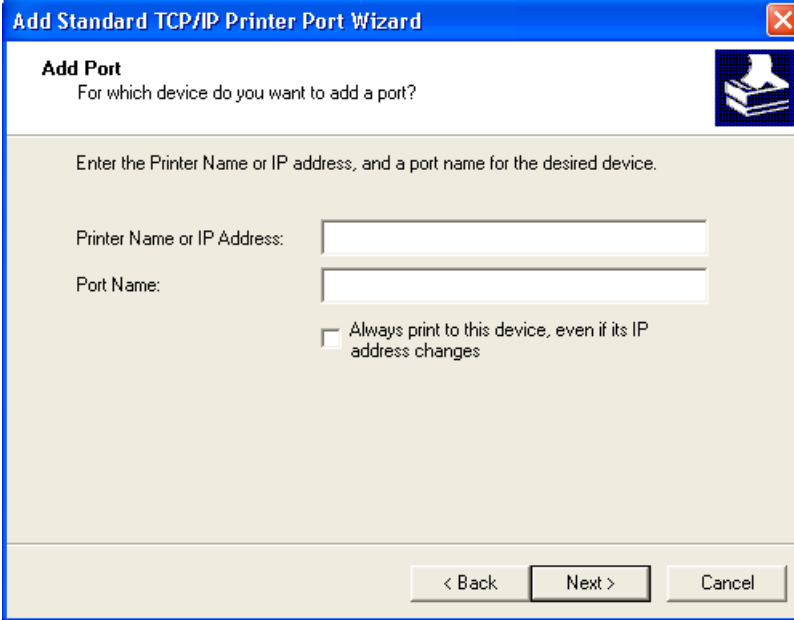

Add Port
For which device do you want to add a port?

Enter the Printer Name or IP address, and a port name for the desired device.

Printer Name or IP Address:

Port Name:

Always print to this device, even if its IP address changes

< Back Next > Cancel

4. Review the installation details, and then click the **Finish** button to complete the Add Printer Wizard.

Print server connection

Perform the following when the product is connected via the network using a print server:

1. If the product is connected via the network using a print server, select the **A network printer, or a printer attached to another computer** option, and then click the **Next >** button.

 **NOTE:** If the product is connected to the computer using a USB cable, or is connected via the network without using a print server, select the **Local printer attached to this computer** option, and then click the **Next >** button. You can also select the **Automatically detect and install my Plug and Play printer** check box prior to clicking the **Next >** button to have the computer automatically install the print driver. For detailed installation instructions, see either [Use an existing port for a direct connection on page 71](#) or see [Create a new TCP/IP port for a direct connection on page 75](#).

Figure 3-19 Add Printer Wizard — Local or Network Printer screen



2. Select either the **Find a printer in the directory** option, the **Connect to this printer (or to browse for a printer, select this option and click Next)** option, or the **Connect to a printer on the Internet or on a home or office network** option, and then click the **Next >** button.

Figure 3-20 Add Printer Wizard — Specify A Printer screen

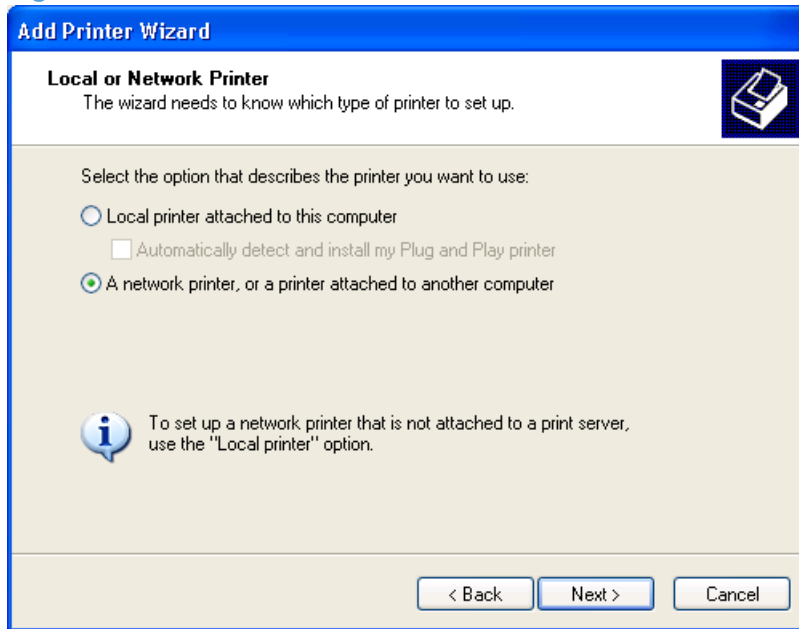
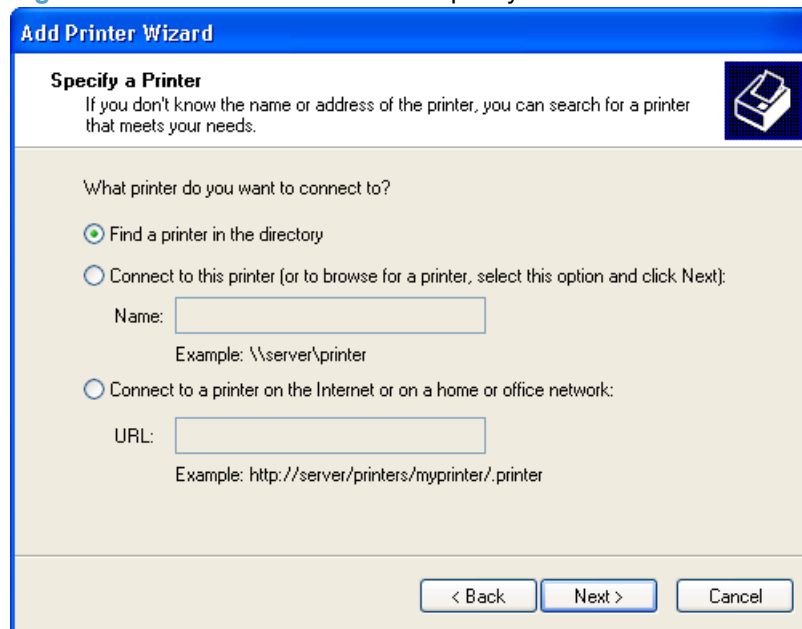

If you select the **Find a printer in the directory** option and then click the **Next >** button, you will continue to the **Find Printers** dialog box.

If you select the **Connect to this printer (or to browse for a printer, select this option and click Next)** option and then click the **Next >** button, you will continue to the **Browse for Printer** dialog box.

If you select the **Connect to a printer on the Internet or on a home or office network** option and then click the **Next >** button, you will continue to the **Completing the Add Printer Wizard** dialog box.

Select one of the following options:

- a. (Find a printer in the directory option only)

Specify search attributes to find your product on the network, and then click the **Find Now** button to search the specified location for your product. Once the search has completed, select the product, and then click the **OK** button to continue to the **Default Printer** dialog box.

Figure 3-21 Add Printer Wizard — Find Printers screen

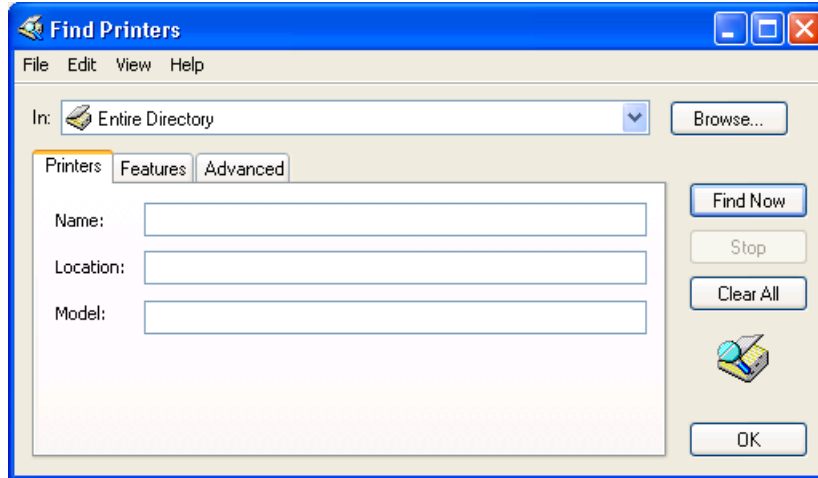

Select either the **Yes** option to use this printer as the default printer, or select the **No** option to keep the existing product as the default printer, and then click the **Next >** button to continue to the **Completing the Add Printer Wizard** dialog box.

Figure 3-22 Add Printer Wizard — Default Printer screen

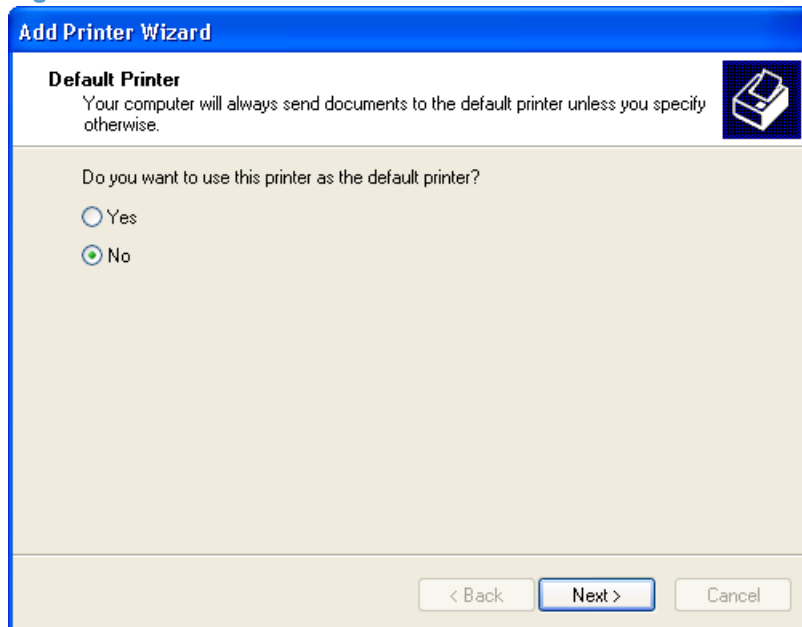

- b. (Connect to this printer (or to browse for a printer, select this option and click Next) option only)

Specify the print path for the product and then click the **Next >** button. The computer will search the network for shared products. Select the product from the list and then click the **Next >** button to continue to the **Completing the Add Printer Wizard** dialog box.

Figure 3-23 Add Printer Wizard — Browse for Printer screen

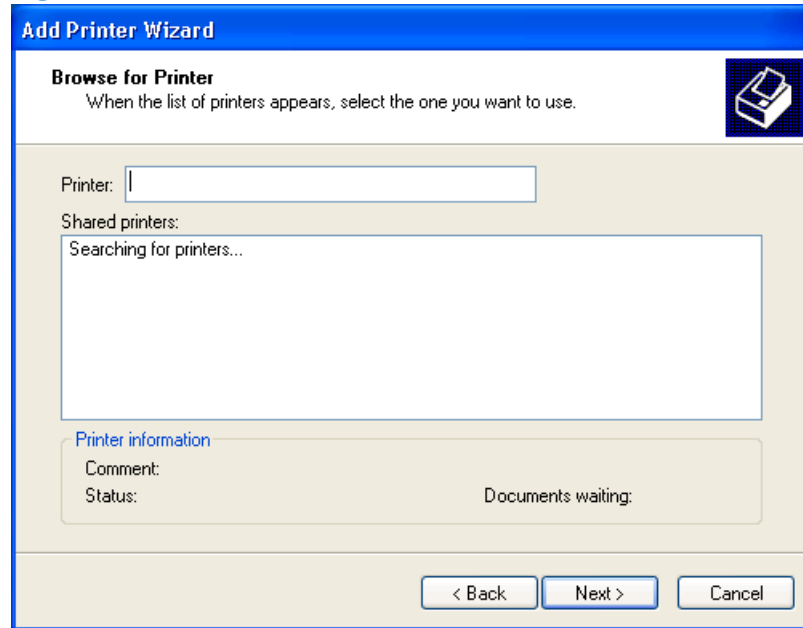

- c. (Connect to a printer on the Internet or on a home or office network option only)

Type the URL for the product, and then click the **Next >** button. Follow the onscreen instructions to connect to the product, and then you will continue to the **Completing the Add Printer Wizard** dialog box.

3. Review the installation details, and then click the **Finish** button to complete the Add Printer Wizard.

Microsoft Windows installation for computers on a network

Install the driver from a network location or from downloaded files

Follow these instructions if you are installing the printing-system files from a network location or from downloaded files. You might need to see your network administrator for the location of the printing-system software file.

1. Browse to the location of the SETUP.EXE file.
2. Double-click the SETUP.EXE file.
3. Click **Install** and continue to follow the instructions until the product is installed. For detailed installation instructions, see [Detailed MS Windows installation instructions on page 89](#).

Install the driver using downloaded files and the HP Driver Installation Utility (HPDIU)

Follow these instructions if you downloaded the driver from the Web. The driver available on the Web uses the HPDIU to install the driver on networked computers.

1. Close all programs.
2. Browse to the location of the SETUP.EXE file.
3. Double-click the SETUP.EXE file.
4. Read the license agreement, and then click **Accept** to continue the installation.

Figure 3-24 Software Installation — License Agreement screen

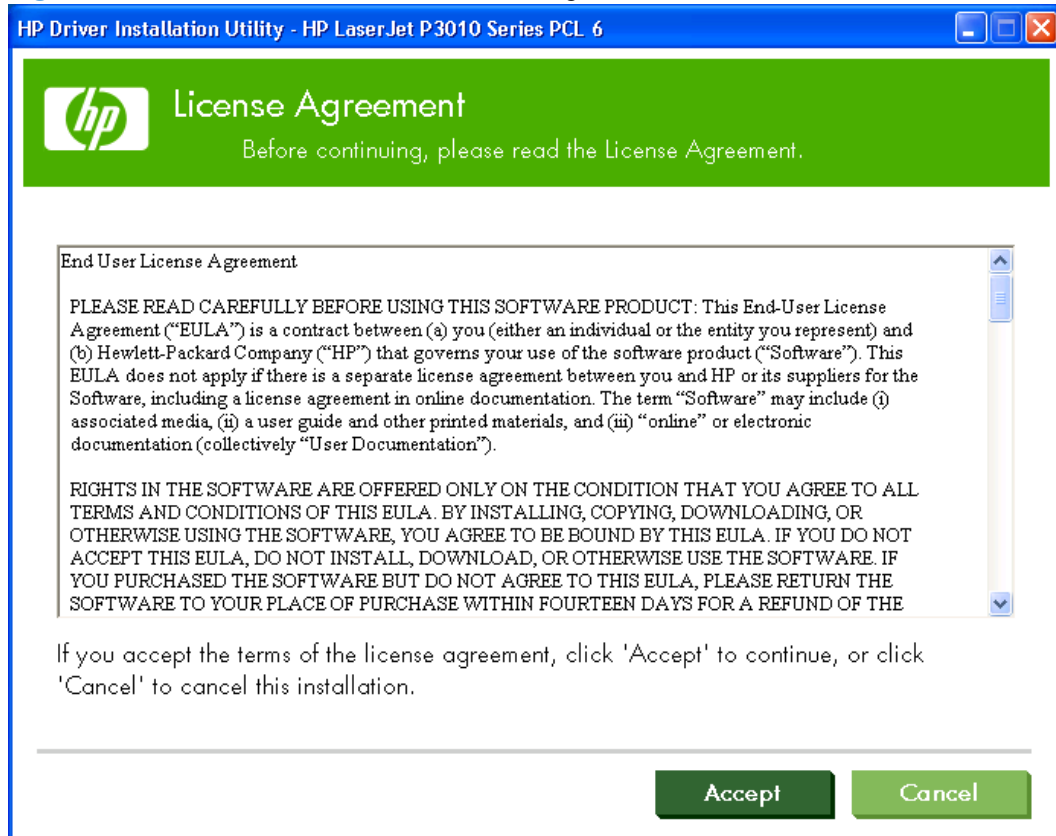

5. The **Device Connection** screen appears. Select an option for how the device will be connected to the computer.

Figure 3-25 Software Installation — Device Connection screen

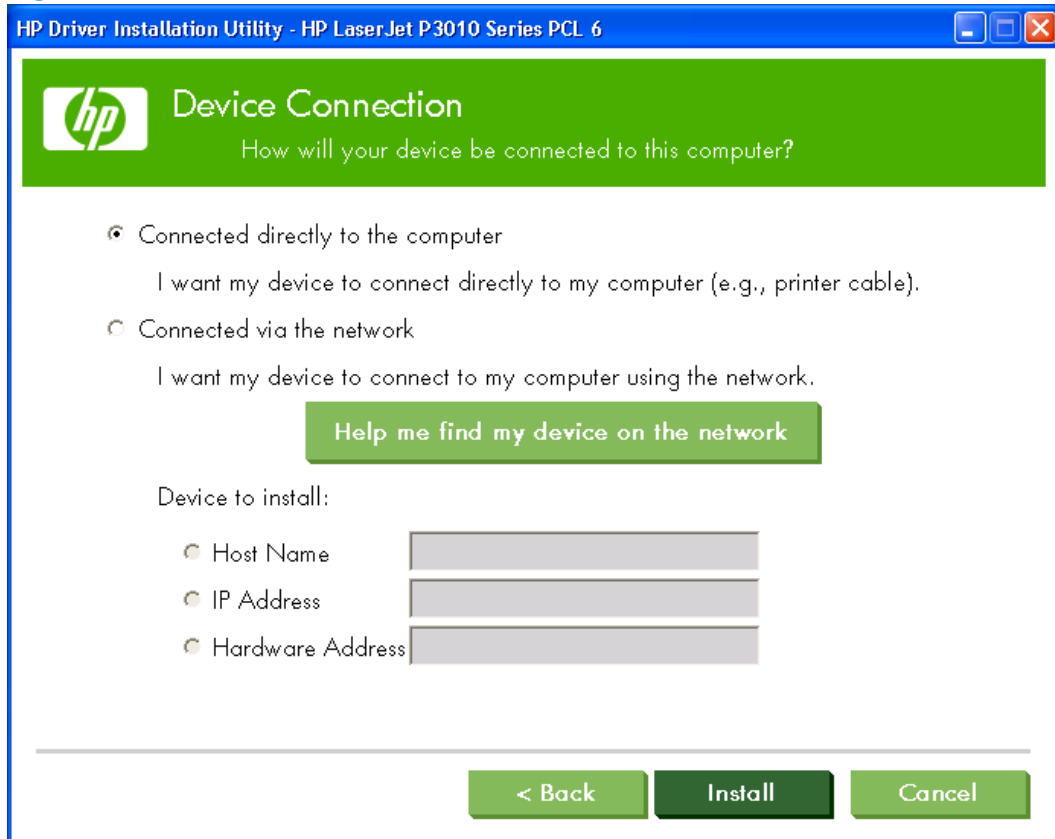

If the device is connected to the product using a USB cable, select the **Connected directly to the computer** option and then click the **Install** button. Once the software is installed, you will continue to the **Driver Installation Complete** screen.

If the device's networking settings are known, select the **Connected via the network** option, enter either the Host Name, IP Address, or the Hardware Address, and then click the **Install** button. Once the software is installed, you will continue to the **Driver Installation Complete** screen.

If the product's network settings are not known, click the **Help me find my device on the network** button. You will continue to the **Devices Found** screen once the computer has finished searching the network for HP LaserJet P3010 Series products.

 **NOTE:** To find the product network settings, follow these directions to print a configuration page from the product control panel.

Print a configuration page

- a. Press the **menu** button  to open the menus.
- b. Press the **up arrow** ▲ or the **down arrow** ▼ to scroll to **INFORMATION**, and then press **OK**.
- c. Press the **up arrow** ▲ or the **down arrow** ▼ to scroll to **PRINT CONFIGURATION**.
- d. Press **OK** to print the configuration page.

6. A list of HP LaserJet P3010 Series products is displayed. Select the product you want to install and click the **OK** button to continue to the **Devices Found** screen.

Figure 3-26 Device Connection — Devices Found screen

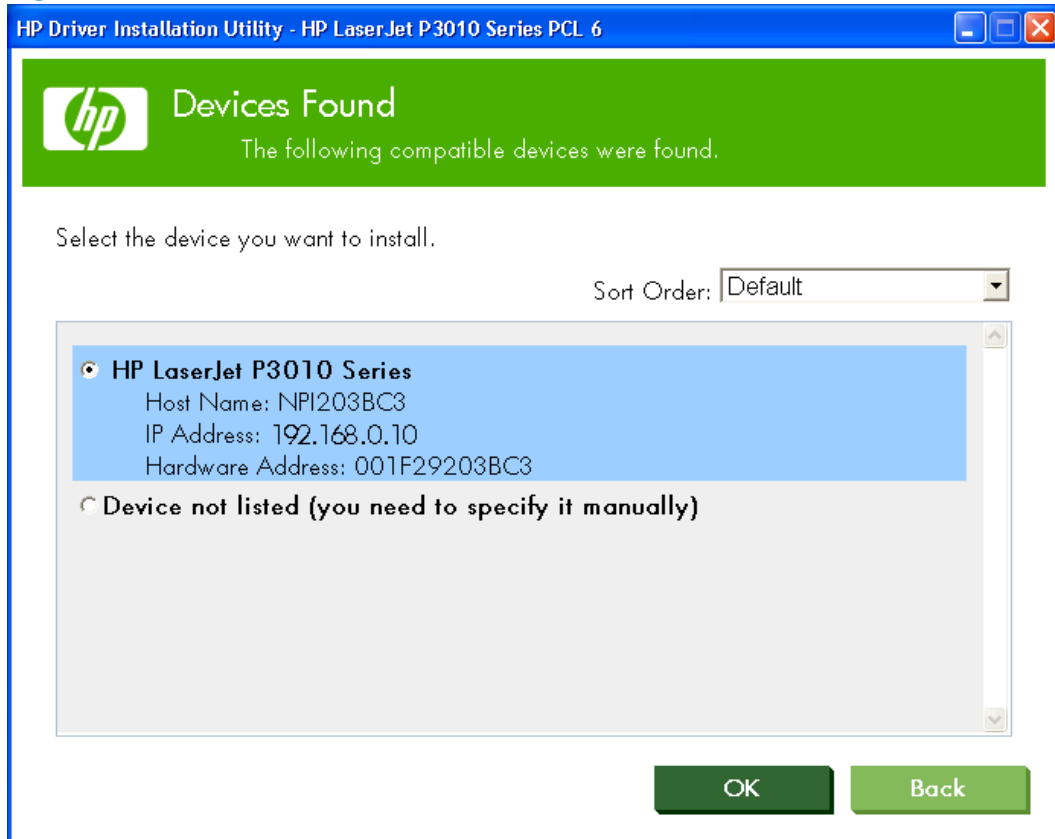

7. The network settings (Host Name, IP Address, and Hardware Address) for the product are displayed. Click the **Install** button. Once the software is installed, you will continue to the **Driver Installation Complete** screen.

Figure 3-27 Software Installation — Device Connection screen 2

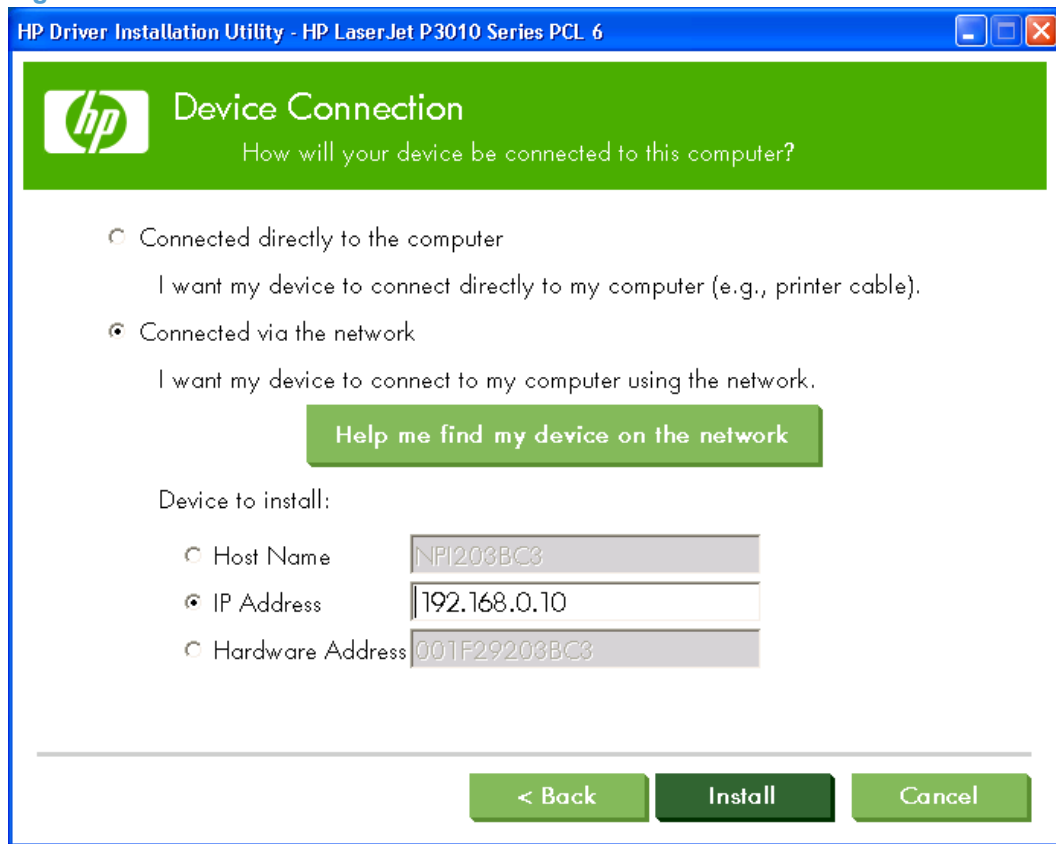

8. If you selected the **Connected directly to the computer** installation method, the following screen will appear at the conclusion of the software installation:

Figure 3-28 Software Installation — Driver Installation Complete – Direct Connection

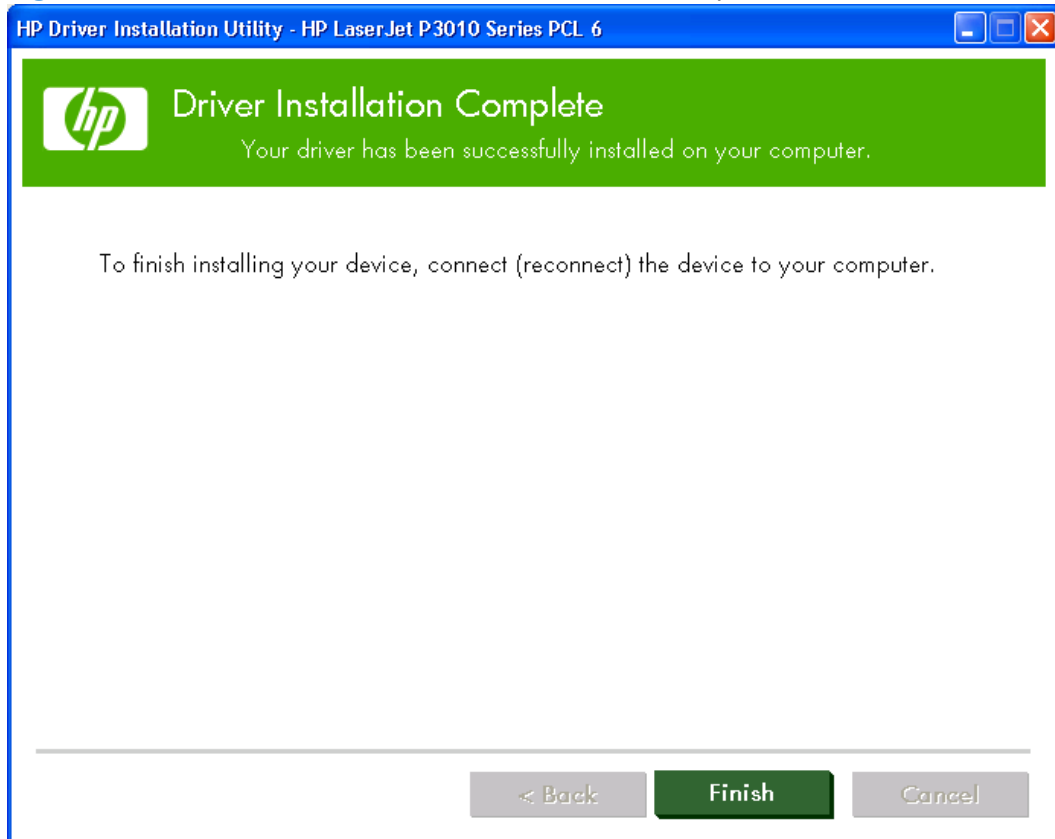

9. If you selected the **Connected via the network** installation method, the following screen will appear at the conclusion of the software installation:

Figure 3-29 Software Installation — Driver Installation Complete – Network connection

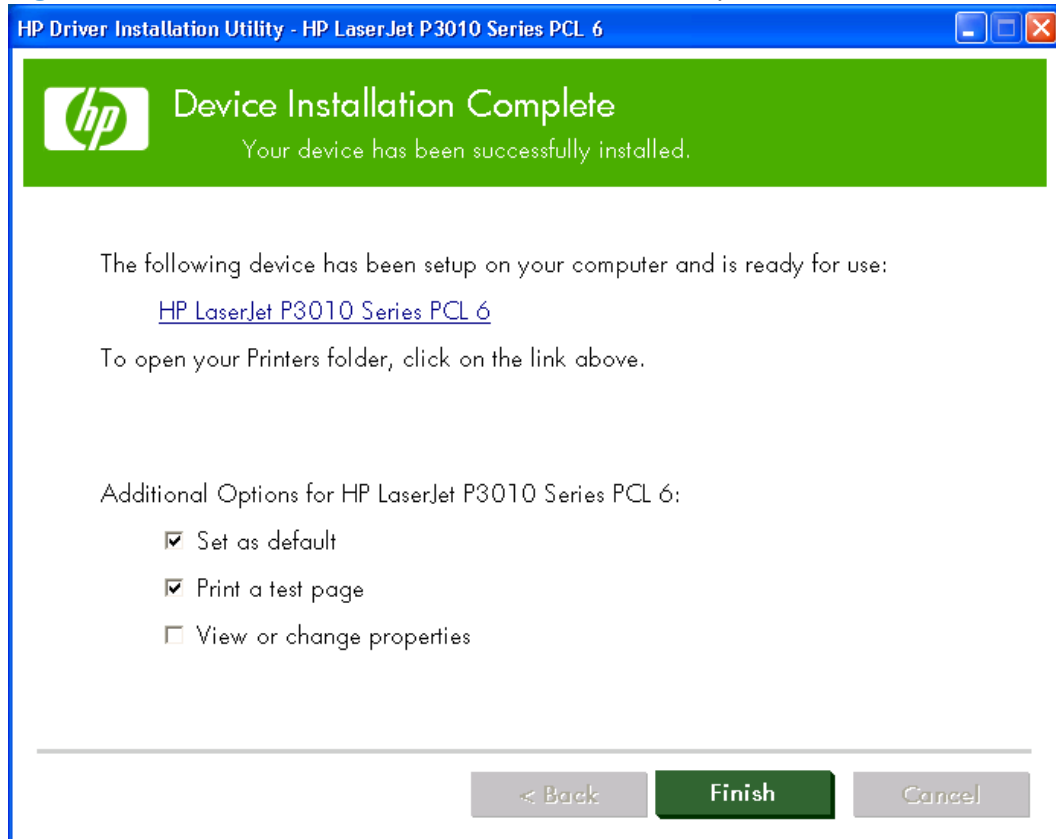

Point and Print installation for Windows 2000 Service Pack 3, XP, Server 2003, Server 2008, and Vista

The following information helps you install a print driver by using the Microsoft Point and Print function when you cannot see the product on the network.

Point and Print is a Microsoft term that describes a two-step driver installation process:

1. Install a shared driver on a network print server.
2. "Point" to the print server from a network client so that the client can use the print driver.

Hewlett-Packard provides drivers that are compatible with the Point and Print feature, but this is a function of the Microsoft operating systems, not of HP print drivers. Windows 2000 Service Pack 3, Windows XP, Windows Server 2003, Windows Server 2008, and Windows Vista drivers from HP are supported only on Intel x86 processor types.

In a homogenous operating system environment (clients and servers running the same operating system), the same print-driver version that is vended from the server to the clients in a Point and Print environment also runs and controls the print queue configuration on the server.

However, in a mixed operating system environment (servers and clients running different operating systems), conflicts can occur when client computers run a version of the print driver that is different from the one on the print server.

In an effort to increase operating system stability, Microsoft determined that in Windows 2000 Service Pack 3 and all future operating systems, print drivers would run as *user-mode* processes. User-mode drivers run in a protected part of the operating system, as do all of the normal end-user processes and software programs. A user-mode print driver that functions incorrectly can terminate (or “crash”) only the process in which it is running—not the whole operating system. Because access to critical system resources is restricted, overall operating system stability is increased.

Detailed MS Windows installation instructions

The dialog boxes shown here appear in the Windows XP Professional installation sequence. The order and appearance of dialog boxes can vary among operating systems.

Perform the recommended print driver installation using the HP Driver Installation Utility (HPDIU)

The recommended installation (**Install Now**) installs the PCL 6 print driver, screen fonts, and user guide. For information about how to perform an advanced (customized) installation, see [Performing an advanced print driver installation using the HP Driver Installation Utility \(HPDIU\) on page 98](#).

A series of dialog boxes appear during installation of the HP LaserJet P3010 Series printing-system software in Windows environments.

 **NOTE:** You can return to the previous dialog box by clicking **Back** or exit the HP LaserJet P3010 Series printing-system software installation by clicking **Cancel** wherever these options appear in the installation sequence.

1. Close all programs.
2. Insert the HP LaserJet P3010 Series printing system software CD into the CD-ROM drive. The software installer detects the language of the operating system, and then displays the main menu of the CD Browser program in the same language.

If the installer program has not started after 30 seconds, complete these steps:

- a. On the **Start** menu, click **Run**.
- b. Type the following: X:\SETUP.EXE (where X is the letter of the CD-ROM drive).
- c. Click **OK**.

3. Click **Install Now** to begin the installation process.

Figure 3-30 Software Installation — Initial screen



4. After reading the license agreement, click the **Accept** button to continue the installation.

Figure 3-31 Software Installation — License Agreement screen

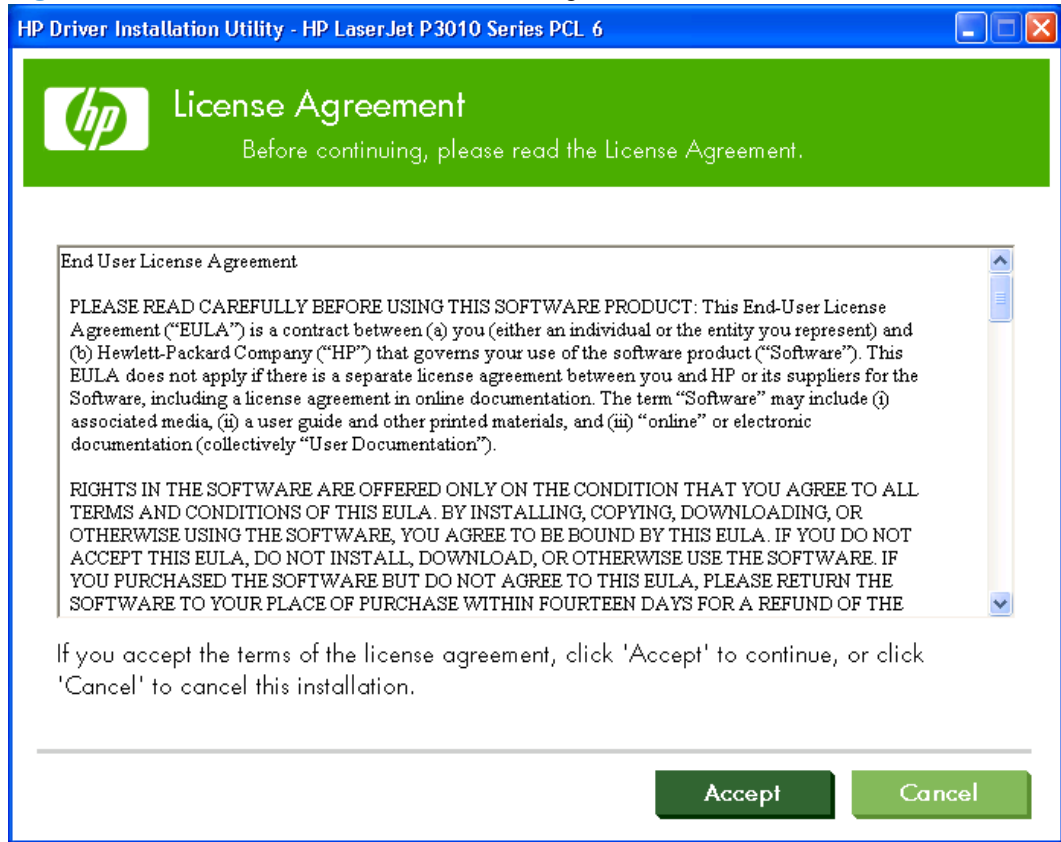

5. The **Device Connection** screen appears. Select an option based on how the product will be connected to the computer.

Figure 3-32 Software Installation — Device Connection screen

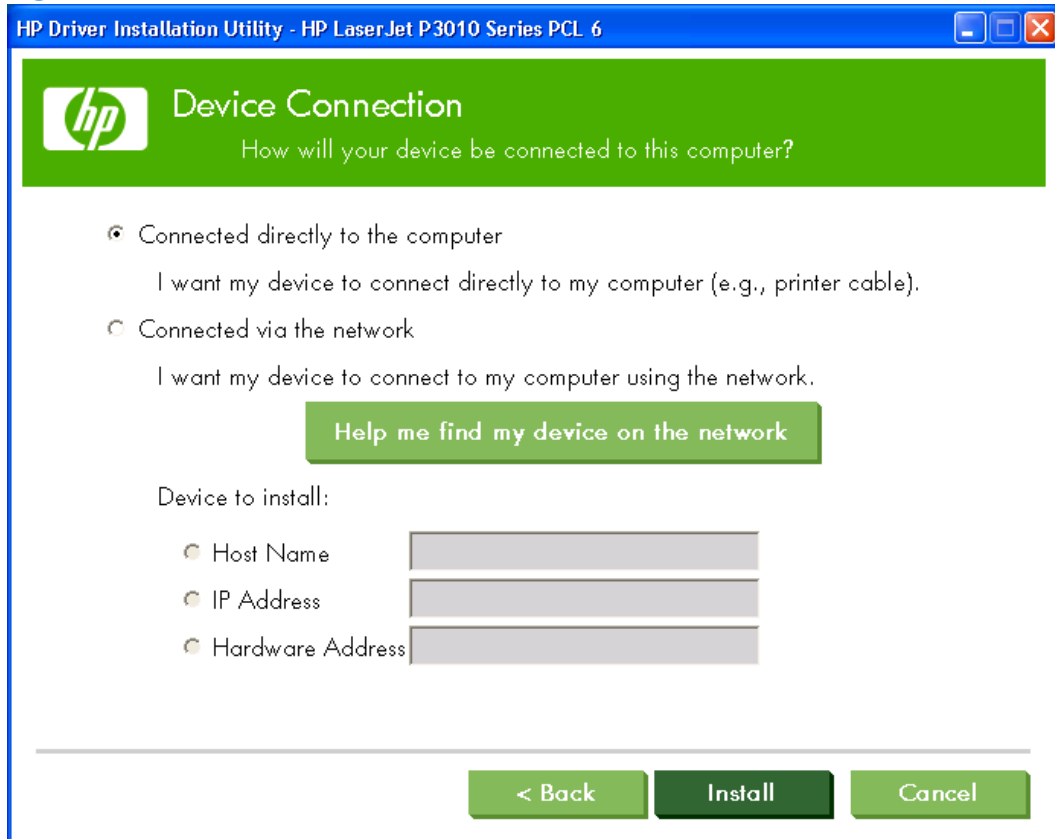

- **Connected directly to the computer:** Select this option and then click the **Install** button if the product will be connected to the computer using a USB cable. Once the software is installed, the **Driver Installation Complete** screen appears.

 **NOTE:** If you choose this option, the printer should not be connected to the computer until prompted during the installation process.

-or-

- **Connected via the network:** Select this option if the product will be connected to the computer using a network cable.
 - If the product's networking settings are known, you can enter either the Host Name, IP Address, or the Hardware Address, and then click the **Install** button. Once the software is installed, the **Driver Installation Complete** screen appears.
 - If the product's network settings are not known, click the **Help me find my device on the network** button. A **Discovery in Progress** window appears. After the computer searches the network, the **Devices Found** screen appears.

6. A list of products is displayed. Select the product you want to install and then click the **OK** button to continue to the **Device Connection** screen.

Figure 3-33 Software Installation — Devices Found screen

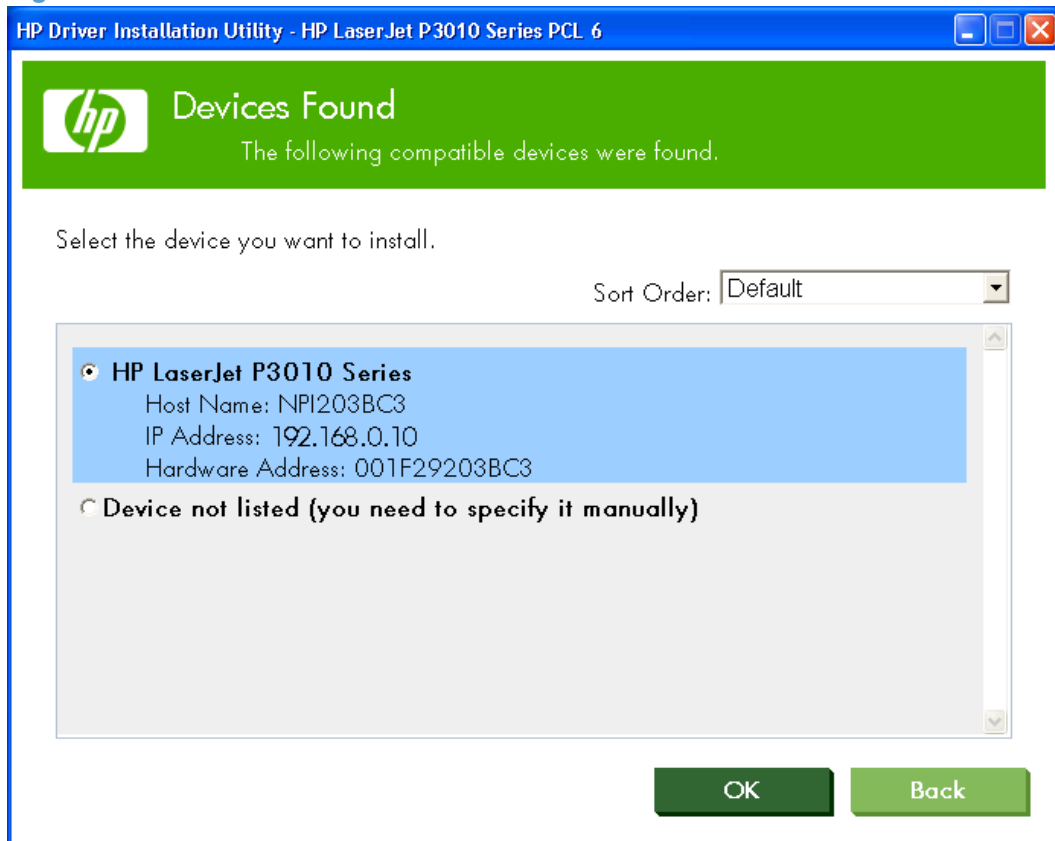

7. The network settings (Host Name, IP Address, and Hardware Address) for the product are displayed. Click the **Install** button. Once the software is installed, you will continue to the **Driver Installation Complete** screen.

Figure 3-34 Software Installation — Device Connection

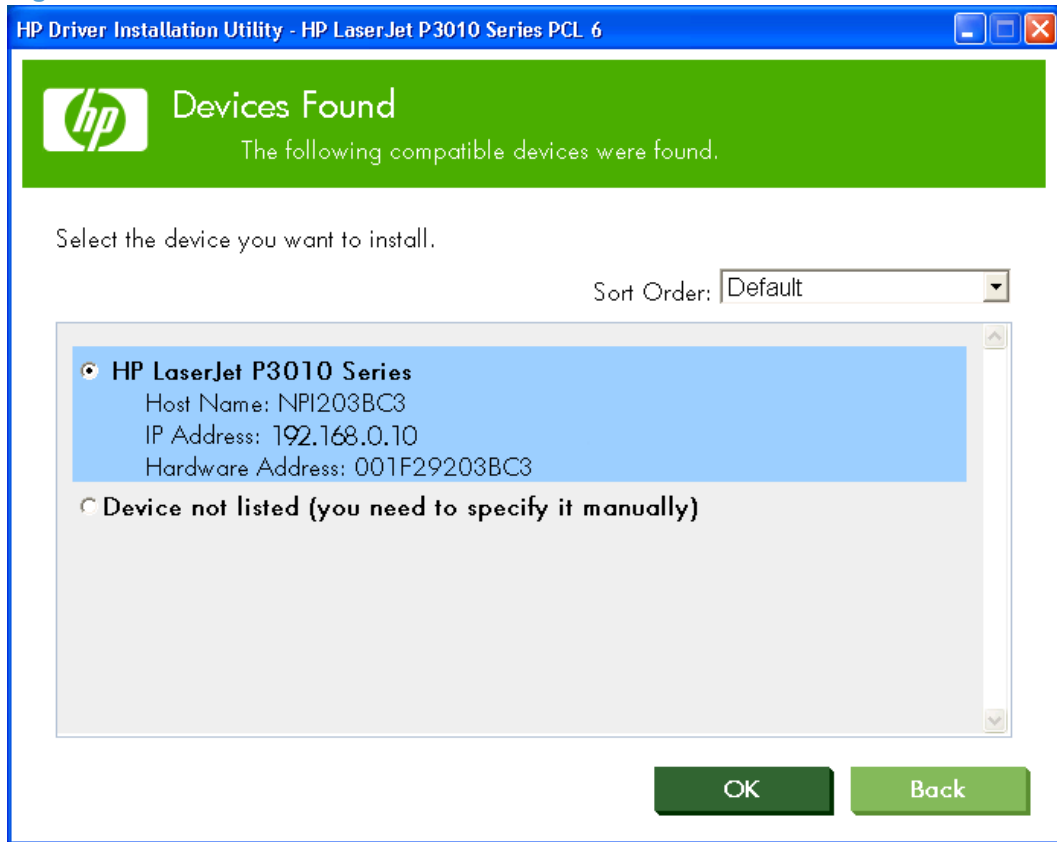

8. Depending on the installation method, one of the following dialog boxes appears at the conclusion of the software installation:
 - If you selected the **Connected directly to the computer** installation method, the following screen appears once the software is installed. Click the **Finish** button to complete the installation.

Figure 3-35 Software Installation — Driver Installation Complete – Direct Connection

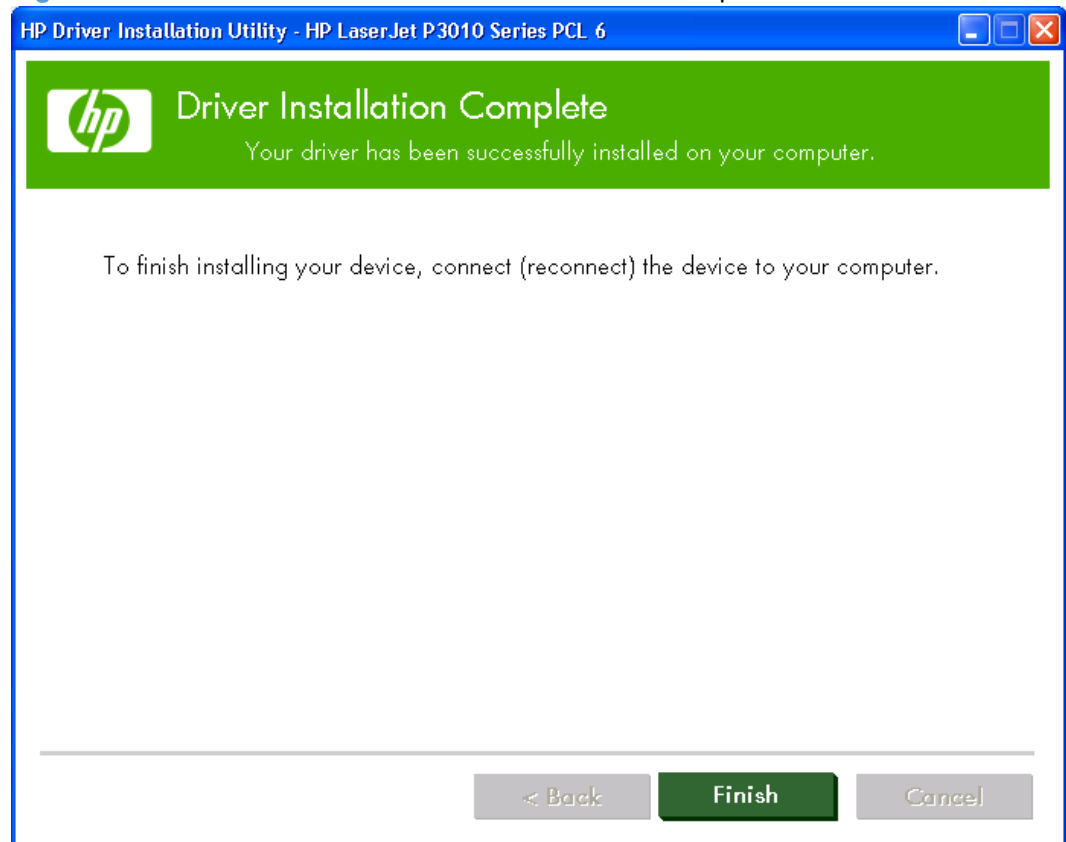

- If you selected the **Connected via the network** installation method, the following screen appears once the software is installed. You can make this your default product by selecting the **Set as default** check box, send a test page to the product by selecting the **Print a test page** check box, or gain access to the print driver by selecting the **View or change properties** check box.

Click the **Finish** button to complete the installation.

Figure 3-36 Software Installation — Driver Installation Complete – Network connection

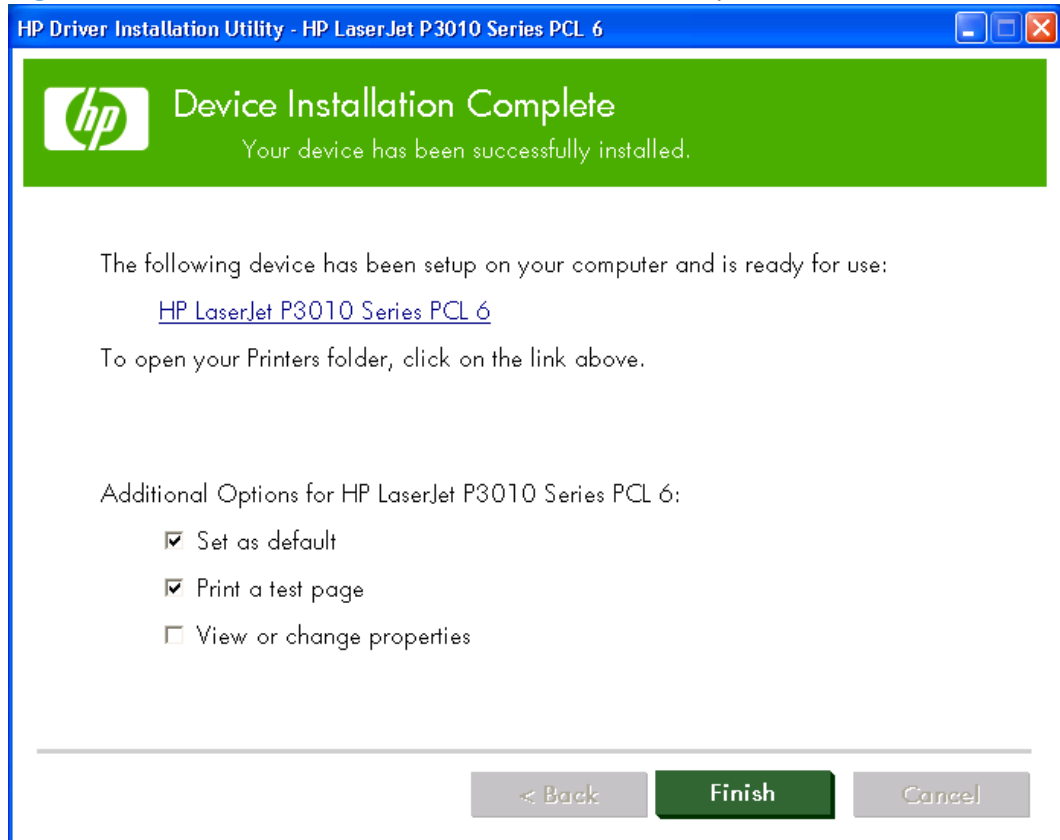

When you are finished with the installation, the Additional Options screen appears.

Figure 3-37 Additional Options

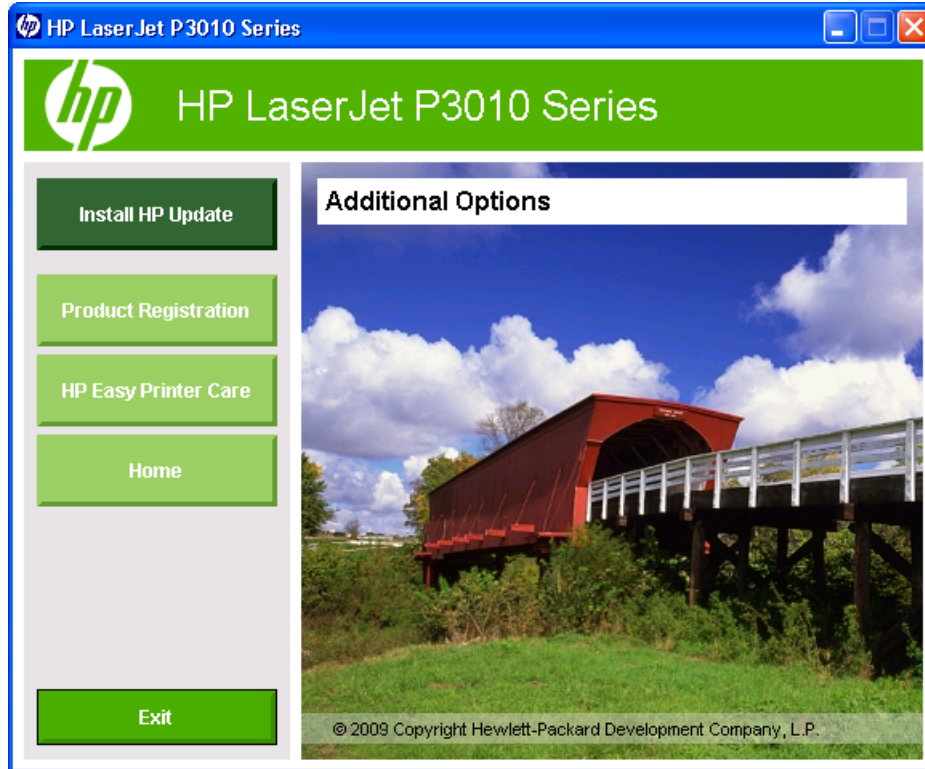

Use the options available on this screen to install HP Update, register your product using Web Registration, and download the HP Easy Printer Care software.

Use the Back, Next, Finish, and Cancel buttons

The following buttons appear on various dialog boxes during the installation process.

- **Back.** Click this button to return to the previous dialog box.
- **Next.** After you select any options on a given screen, click this button to proceed to the next step in the installation sequence.
- **Finish.** Click this button to complete the installation process and proceed to the **Additional Options** screen.

- **Cancel.** Click this button to exit the installer without installing the product. When you click **Cancel**, the **Installation Cancelled** dialog box opens, stating that the installation was cancelled.

Figure 3-38 Installation Cancelled dialog box

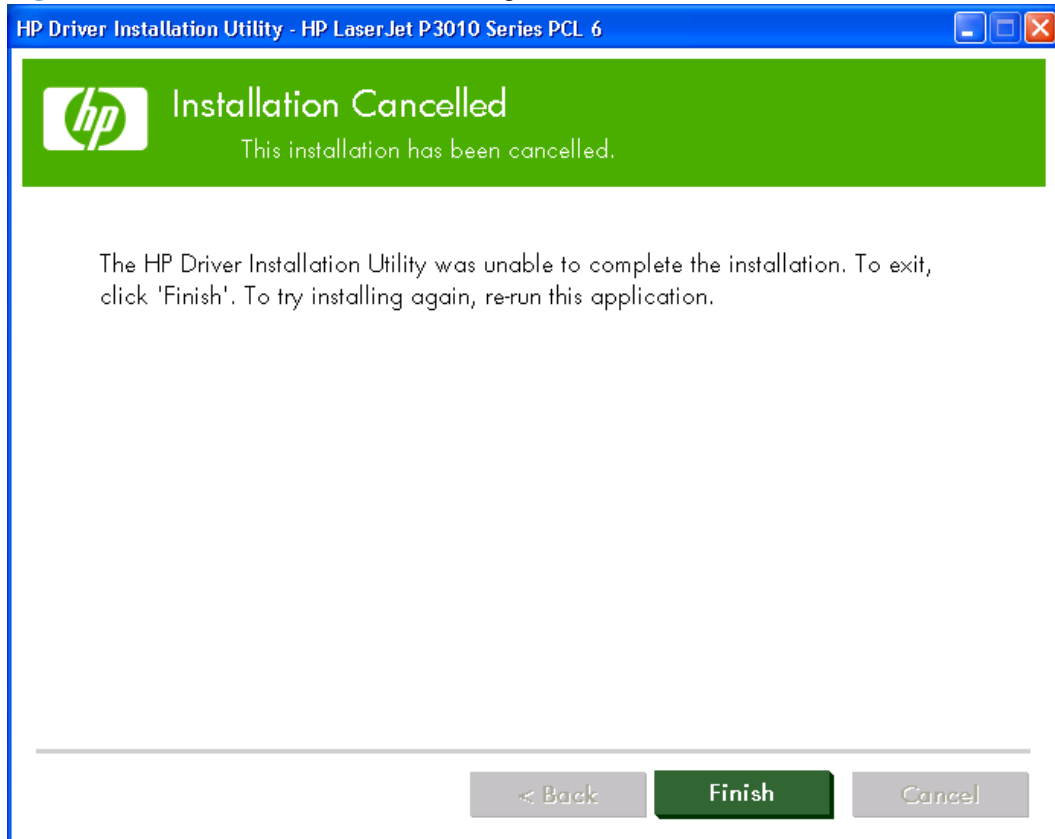

Click **Finish** to close the installer.

Performing an advanced print driver installation using the HP Driver Installation Utility (HPDIU)

The advanced installation enables you to select the print drivers and software that you want to install.

A series of dialog boxes appear during installation of the HP LaserJet P3010 Series printing-system software in Windows environments.

NOTE: You can return to the previous dialog box by clicking **Back** or exit the HP LaserJet P3010 Series printing-system software installation by clicking **Cancel** wherever these options appear during the installation.

1. Close all programs.
2. Insert the HP LaserJet P3010 Series printing system software CD into the CD-ROM drive. The software installer detects the language of the operating system, and then displays the main menu of the CD Browser program in the same language.

If the installer program has not started after 30 seconds, complete these steps:

- a. On the **Start** menu, click **Run**.
- b. Type the following: X:\SETUP.EXE (where X is the letter of the CD-ROM drive).

- c. Click **OK**.

This screen appears when the HP LaserJet P3010 Series software CD is inserted into the CD-ROM drive.

Figure 3-39 Software Installation — Initial screen



3. Click the **Advanced Install Options** button to view the **Advanced Install Options** screen.

Figure 3-40 Software Installation — Advanced Installation Options screen



4. Click the button for the print driver that you want to install. This begins the installation process.

5. After reading the license agreement, click the **Accept** button to continue to the **Device Connection** screen.

Figure 3-41 Software Installation — License Agreement screen

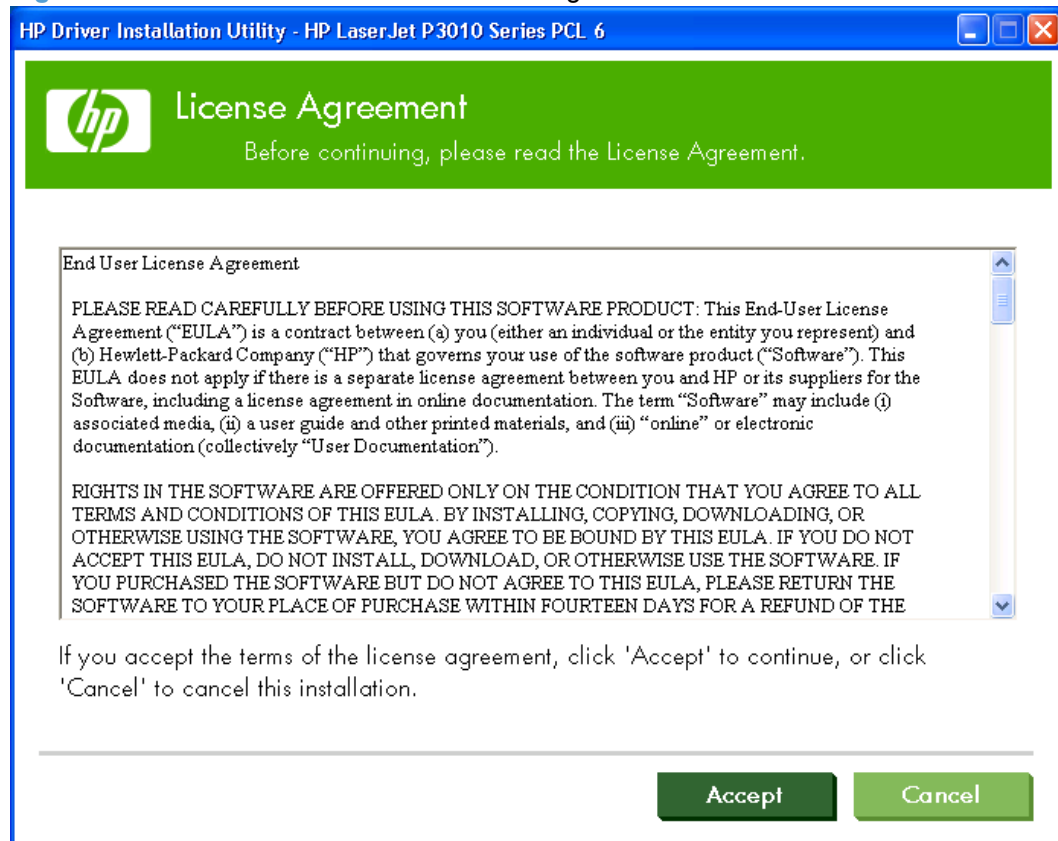

6. Select an option based on how the product will be connected to the computer.

Figure 3-42 Software Installation — Device Connection screen

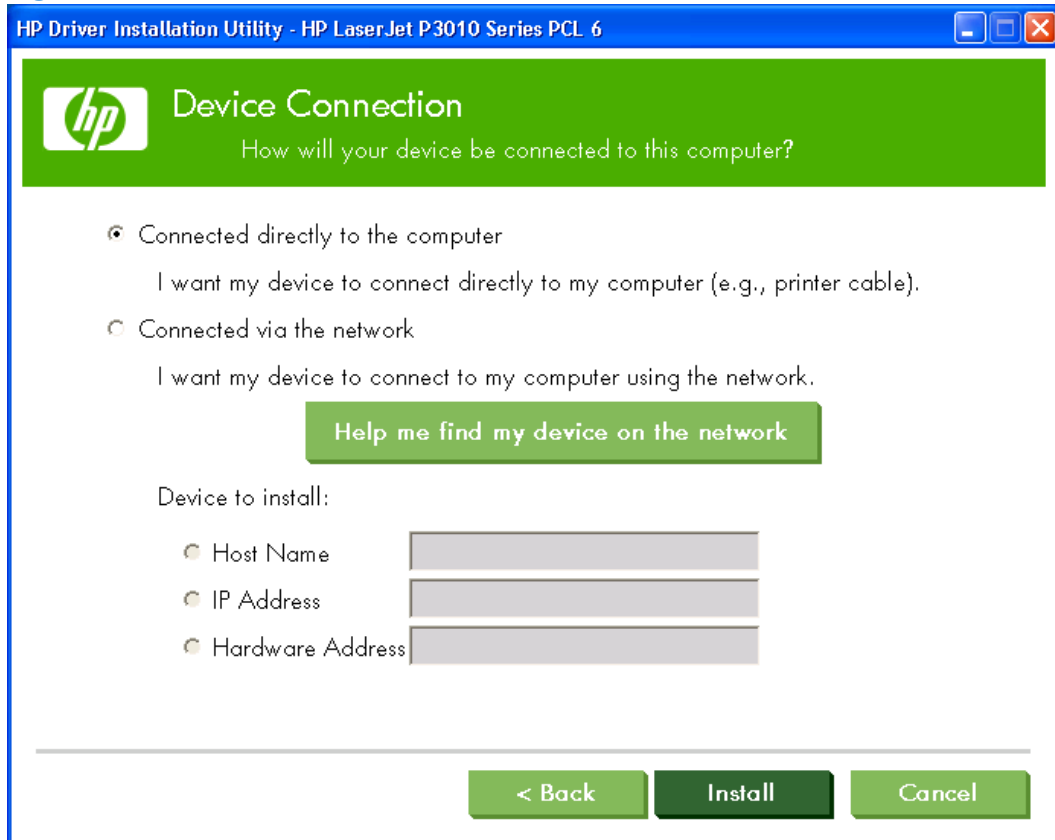

- **Connected directly to the computer:** Select this option and then click the **Install** button if the product will be connected to the computer using a USB cable. Once the software is installed, the **Driver Installation Complete** screen appears.

 **NOTE:** If you choose this option, the printer should not be connected to the computer until prompted during the installation process.

-or-

- **Connected via the network:** Select this option if the product will be connected to the computer using a network cable.
 - If the product's networking settings are known, you can enter either the **Host Name**, **IP Address**, or the **Hardware Address**, and then click the **Install** button. Once the software is installed, the **Driver Installation Complete** screen appears.
 - If the product's network settings are not known, click the **Help me find my device on the network** button. A **Discovery in Progress** window appears. After the computer searches the network, the **Devices Found** screen appears.

7. A list of products is displayed. Select the product you want to install and then click the **OK** button to continue to the **Device Connection** screen.

Figure 3-43 Software Installation — Devices Found

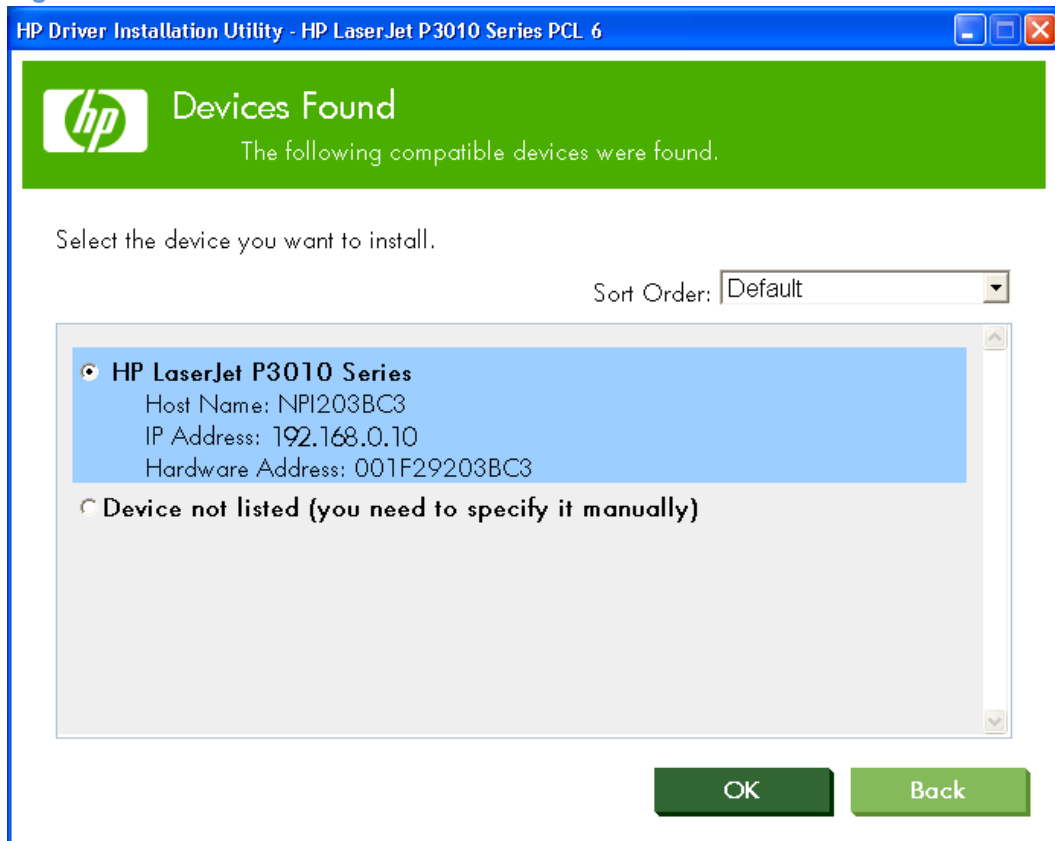

8. The network settings (Host Name, IP Address, and Hardware Address) for the product are displayed. Click the **Install** button. Once the software is installed, you will continue to the **Driver Installation Complete** screen.

Figure 3-44 Software Installation — Device Connection

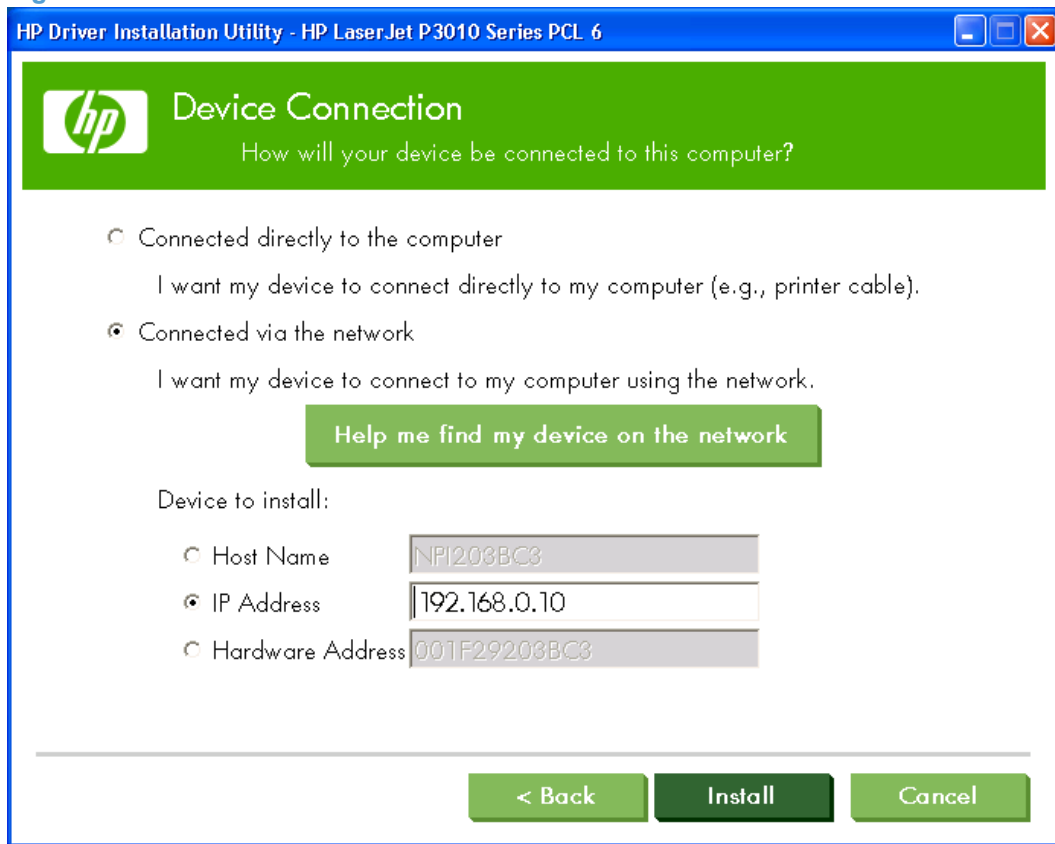

9. Depending on the installation method, one of the following dialog boxes appears at the conclusion of the software installation:
 - If you selected the **Connected directly to the computer** installation method, the following screen appears once the software is installed. Click the **Finish** button to complete the installation.

Figure 3-45 Software Installation — Driver Installation Complete screen

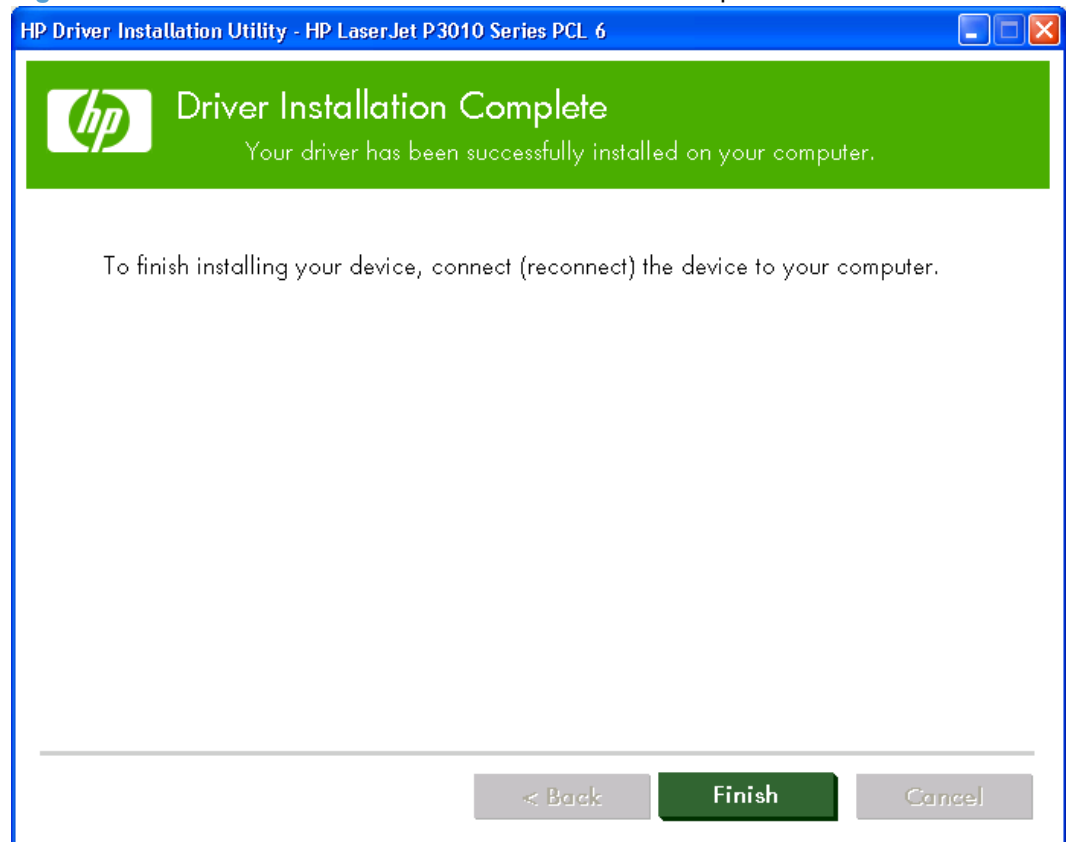

- If you selected the **Connected via the network** installation method, the following screen appears once the software is installed. You can make this your default product by selecting the **Set as default** check box, send a test page to the product by selecting the **Print a test page** check box, or gaining access to the print driver by selecting the **View or change properties** check box.

Click the **Finish** button to complete the installation.

Figure 3-46 Software Installation — Driver Installation Complete screen 2

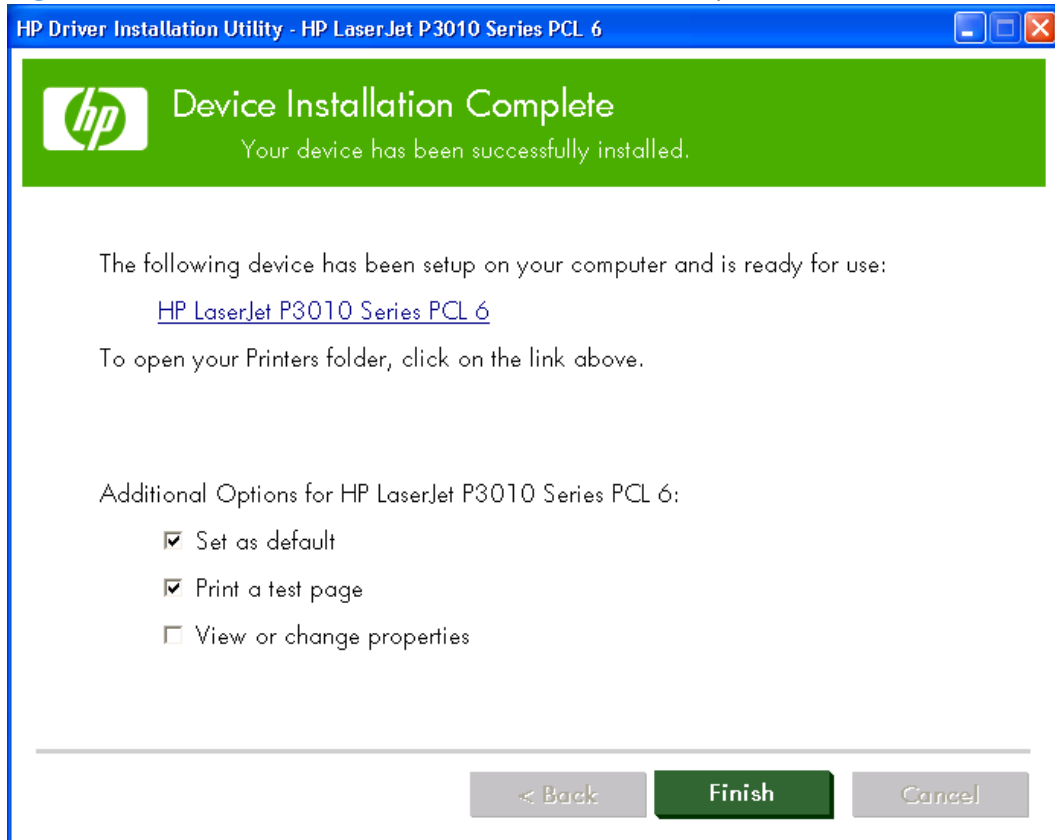

When the installation is complete, the **Additional Options** screen appears.

You can click on any of the **Additional Options** buttons, return to the **Home** screen, or exit the HPDIU.

Figure 3-47 Software Installation — Additional Options screen

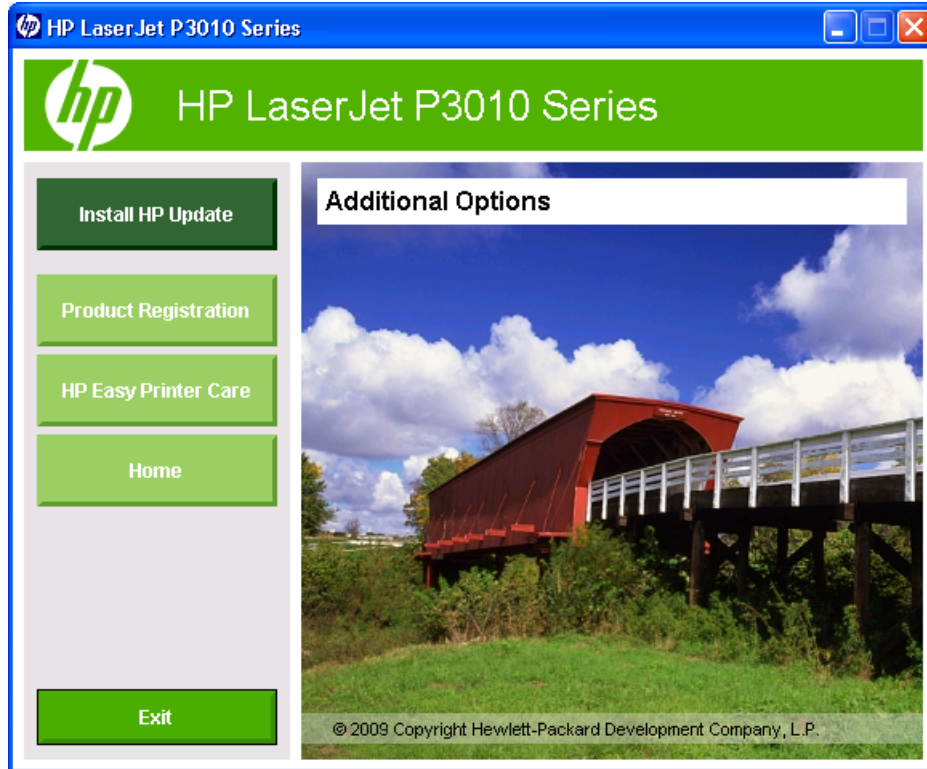

Use the options available on this screen to install HP Update and marketing resources software, download the HP Easy Printer Care software, check online for product-specific merchandise, and register your product using Web Registration.

Set a default printer

1. In Windows Vista, click the **Start** button, click **Control Panel**, and then click **Hardware and Sound**. Under the **Printers** section, click **Change default printer**.

In Windows XP, Windows Server 2003, and Windows Server 2008, click **Start**, click **Control Panel**, and then click **Printers and Faxes** (Windows XP Professional) or **Printers and other hardware devices** (Windows XP Home).

In Windows 2000 Service Pack 3 operating systems, click **Start**, click **Settings**, and then click **Printers**.

2. Right-click the product that you want to set as the default printer.
3. Click **Set As Default**. A check mark appears next to the menu option.

Install documentation and optional software

The following optional software programs are available for the product:

- Shop for HP Supplies – this utility helps you order supplies using HP SureSupply, where you can view a list of the cartridges that work with your printer(s) and shop from a variety of online sources.
- HP LaserJet P3010 Series printer Screen Fonts: Printer-matching TrueType fonts to help ensure screen match printing.
- HP LaserJet P3010 Series User Guide – this is the product user guide.

 **NOTE:** This screen also contains a link to the HP web site where you can download and install the PS Universal Print Driver.

1. Insert the HP LaserJet P3010 Series printing-system software CD into the CD-ROM drive. The installer program should open.

If the installer program has not started after 30 seconds, complete these steps:

- a. On the **Start** menu, click **Run**.
 - b. Type the following: X:\SETUP.EXE (where X is the letter of the CD-ROM drive).
 - c. Click **OK**.
2. Click **Advanced Install Options** to open the **Advanced Installation Options** screen.
 3. Click **Optional Software**.
 4. Accept the License Agreement and then click either the **Add** or the **Remove** button next to the documentation or optional software program you want to install or uninstall.

Figure 3-48 Install or Uninstall Software

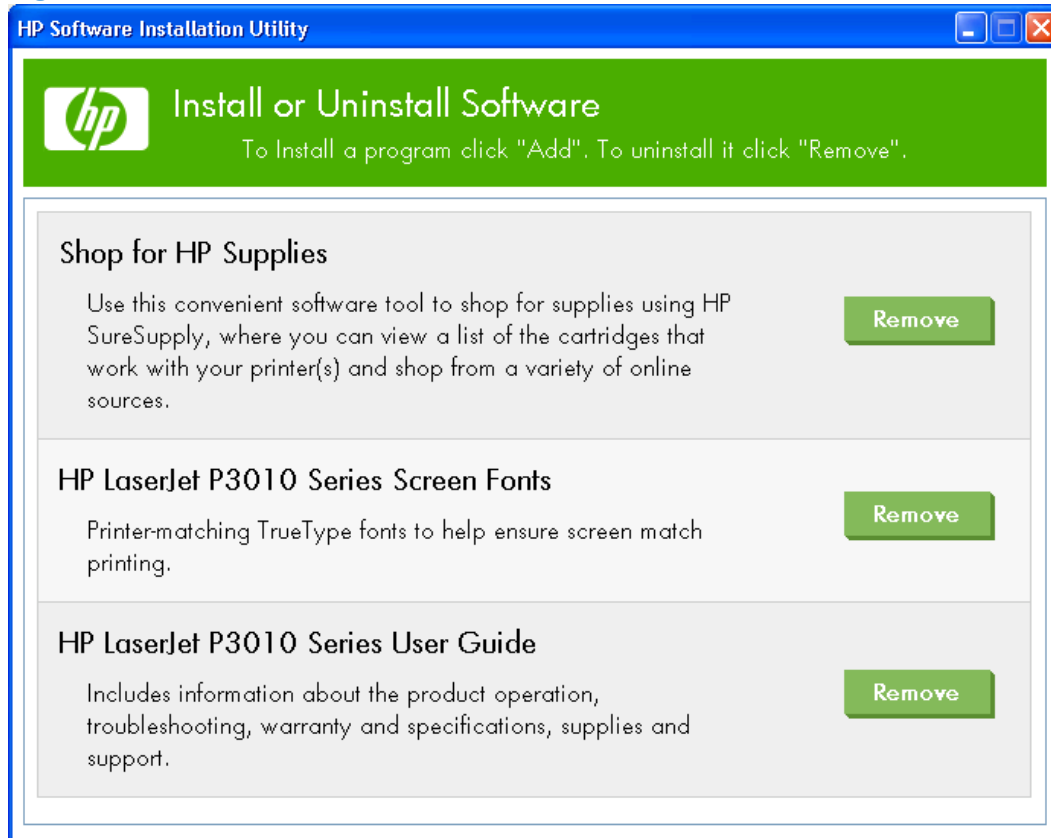

Uninstall software

Use these instructions to uninstall the product using the Windows Add or Remove Programs feature.

NOTE: You must have Administrator privileges to uninstall the product using Add or Remove Programs.

1. In Windows Vista, click the **Start** button, click **Control Panel**, and then click **Add or Remove Programs**.

In Windows XP, Windows Server 2003, and Windows Server 2008, click **Start**, click **Control Panel**, and then double-click **Add or Remove Programs**.

In Windows 2000 Service Pack 3, click **Start**, click **Settings**, click **Control Panel**, and then click **Add or Remove Programs**.

2. Click the entry for the HP LaserJet P3010 Series product, and then click **Remove**. The following screen appears.

Figure 3-49 Uninstall

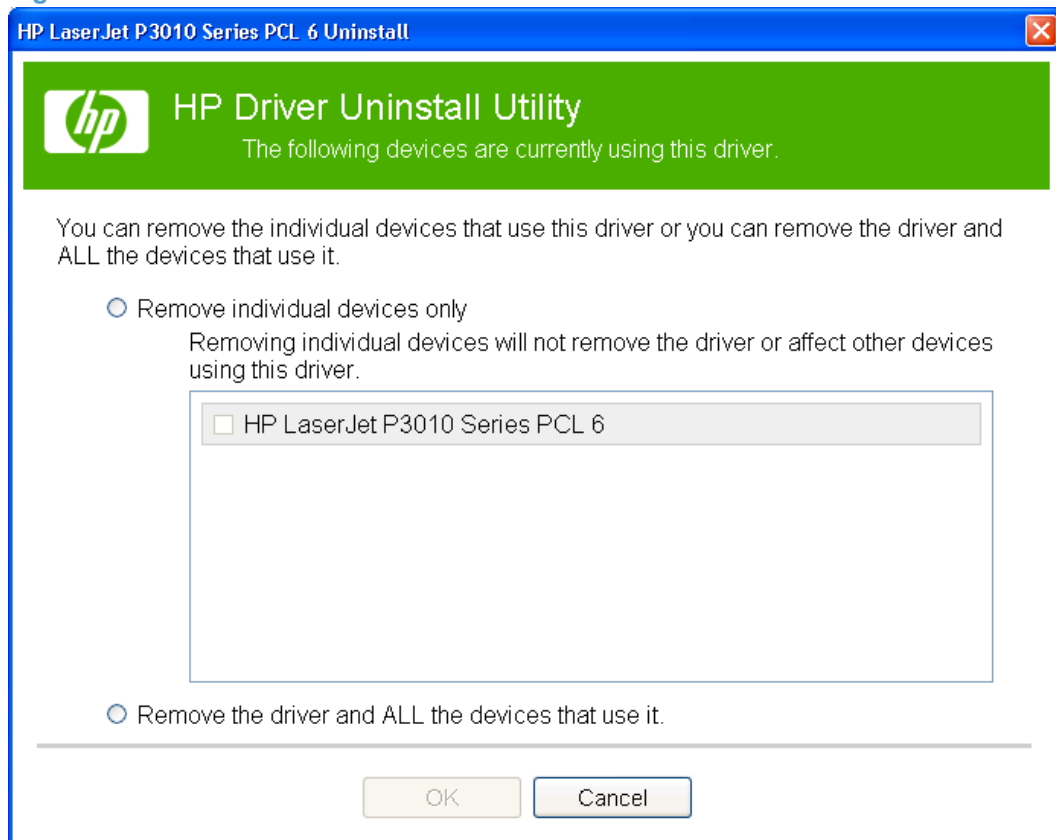

Select the uninstall option that you want to perform, and then click **OK** to initiate the uninstall process.

4 HP PCL 6 Print Driver for Windows

Introduction

This chapter describes the features of the HP LaserJet P3010 Series PCL 6 Print Driver for Windows 2000 Service Pack 3, Windows XP (32-bit and 64-bit), Windows Server 2003 (32-bit and 64-bit), Windows Vista (32-bit and 64-bit), and Windows Server 2008 (32-bit and 64-bit).

You can control print jobs from several places:

- The product control panel
- The software program print dialog box
- The driver user interface

Generally, for features that are duplicated in more than one location (for instance, you can select the paper input tray from any of them), settings that are established in the software program take precedence over print-driver settings. Print-driver settings, in turn, override product control-panel settings.

When you install the printing-system software in Microsoft Windows 2000 Service Pack 3, Microsoft Windows XP, Microsoft Windows Server 2003, Microsoft Windows Vista, and Windows Server 2008, the HP PCL 6 Print Driver is the recommended driver and the first selection in the CD Browser. A product-specific PS print driver, based on the HP PS Universal Print Driver is also available from the CD. The HP PS Universal Print Driver and the HP PCL 5 Universal Print Driver can be installed by download from hp.com (link in browser button). An installer is included with the driver.

Topics:

- [Gain access to print drivers](#)
- [Help system](#)
- [Advanced tab features](#)
- [Printing Shortcuts tab features](#)
- [Paper/Quality tab features](#)
- [Effects tab features](#)
- [Finishing tab features](#)
- [Job Storage tab features](#)
- [Services tab features](#)
- [Device Settings tab features](#)

- [About tab features](#)

Gain access to print drivers

Depending on the operating system on which you are installing the print drivers, you can gain access to the print drivers and different print-driver interfaces in several ways.

To gain access to the print-driver settings from within most software programs, follow these steps:

1. Click **File**.
2. Click **Print**.
3. Click **Properties**.

The appearance and names of the driver tabs can vary, depending on the operating system. These driver settings apply only while that software program is open.

You can control the drivers directly from the **Printers** folder. Here you have access to two sets of driver tabs: the **Printing Preferences** tabs and the **Properties** tabs. The settings that you make on the **Printing Preferences** driver tabs control the driver default settings for each user's profile. Installable options can be configured in the **Properties** driver tabs.

Printing Preferences driver tabs

The **Printing Preferences** driver tabs change the default settings that are used across all software programs. To gain access to these tabs, follow these steps:

1. **Windows Vista:** Click **Start**, click **Control Panel**, click **Hardware and Sound**, and then click **Printers**.

Windows XP and Windows Server 2003: Click **Start**, click **Settings**, and then click **Printers and Faxes**.

Windows 2000: Click **Start**, click **Settings**, and then click **Printers**.

Windows Server 2008: Click **Start**, click **Control Panel**, and then open the **Printers** folder.

2. Right-click the product name.
3. Click **Printing Preferences**.

The following **Printing Preferences** print-driver tabs are available:

- **Advanced**
- **Printing Shortcuts**
- **Paper/Quality**
- **Effects**
- **Finishing**
- **Job Storage**
- **Services**

Properties driver tabs

This set of tabs controls the driver behavior and driver connections. To gain access to the **Properties** tabs, follow these steps:

1. **Windows Vista:** Click **Start**, click **Control Panel**, click **Hardware and Sound**, and then click **Printers**.

Windows XP and Windows Server 2003: Click **Start**, click **Settings**, and then click **Printers and Faxes**.

Windows 2000: Click **Start**, click **Settings**, and then click **Printers**.

Windows Server 2008: Click **Start**, click **Control Panel**, and then open the **Printers** folder.

2. Right-click the product name.
3. Click **Properties**.

The following **Properties** print-driver tabs are available:

- **General**
- **Sharing**
- **Ports**
- **Advanced**
- **Security**
- **Device Settings**
- **About**

Help system

The HP PCL 6 print driver includes a full-featured Help system to provide assistance with printing and configuration options.

“What's this?” Help

Windows 2000 Service Pack 3, Windows XP, Windows Server 2003, Windows Server 2008, and Windows Vista support **What's this?** Help. You can gain access to What's this? Help messages in any of the following ways:

- Right-click a feature or control. A pop-up Help window appears.
- Click the ? question mark button in the upper-right corner of the frame, next to the **X**, to change the cursor to an arrow with a question mark. When you use this special cursor to select a control, the pop-up Help window for that control appears.
- Click a feature or control, and then press the **F1** key. The Help window for the currently selected control appears.

Incompatible Print Settings messages

Incompatible Print Settings (constraint) messages are unsolicited messages that appear in response to specific print-driver selections. These messages alert you to selections that are illogical or impossible given the product capabilities or the current settings of other controls.

 **NOTE:** Constraint messages are limited, and the underlying software architecture might accept some settings that are illogical or impossible for the product to perform. Sending a job with incompatible settings can lead to unexpected results. If print jobs do not print as expected, check the product documentation for the product capabilities.

In supported Windows operating environments, some technically invalid print-driver configurations result in warning messages. Duplexing, for example, is not possible when the Transparency paper type is selected. The following figure shows an **Incompatible Print Settings** message.

Figure 4-1 An **Incompatible Print Settings** message

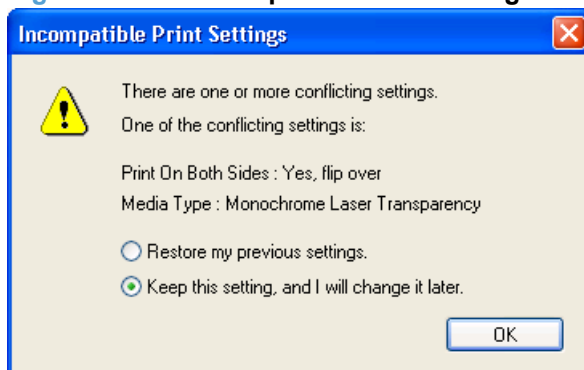

To resolve the conflicting settings, click **Restore my previous settings.** and then click **OK.** The driver resets the conflicting control back to its previous state.

If you want to keep the conflicting setting, click **Keep this setting, and I will change it later.** and then click **OK.**

 **NOTE:** In this example, the conflict can be resolved manually. If the conflict is not resolved when the driver is closed, then the same message appears again when a print job is sent to the product.

Advanced tab features

 **NOTE:** The **Advanced** tab is in the **Printing Preferences** tab set. For information about how to gain access to these tabs, see [Printing Preferences driver tabs on page 113](#).

Use the **Advanced** tab to change the layout of printed pages. Use this tab to configure special controls that are not commonly used, as well as to control features such as paper size and copies in the driver (although most current software programs support these features in the **Print** dialog box or through the page settings in the software program). The following figure shows the **Advanced** tab.

Figure 4-2 The default appearance of the **Advanced** tab

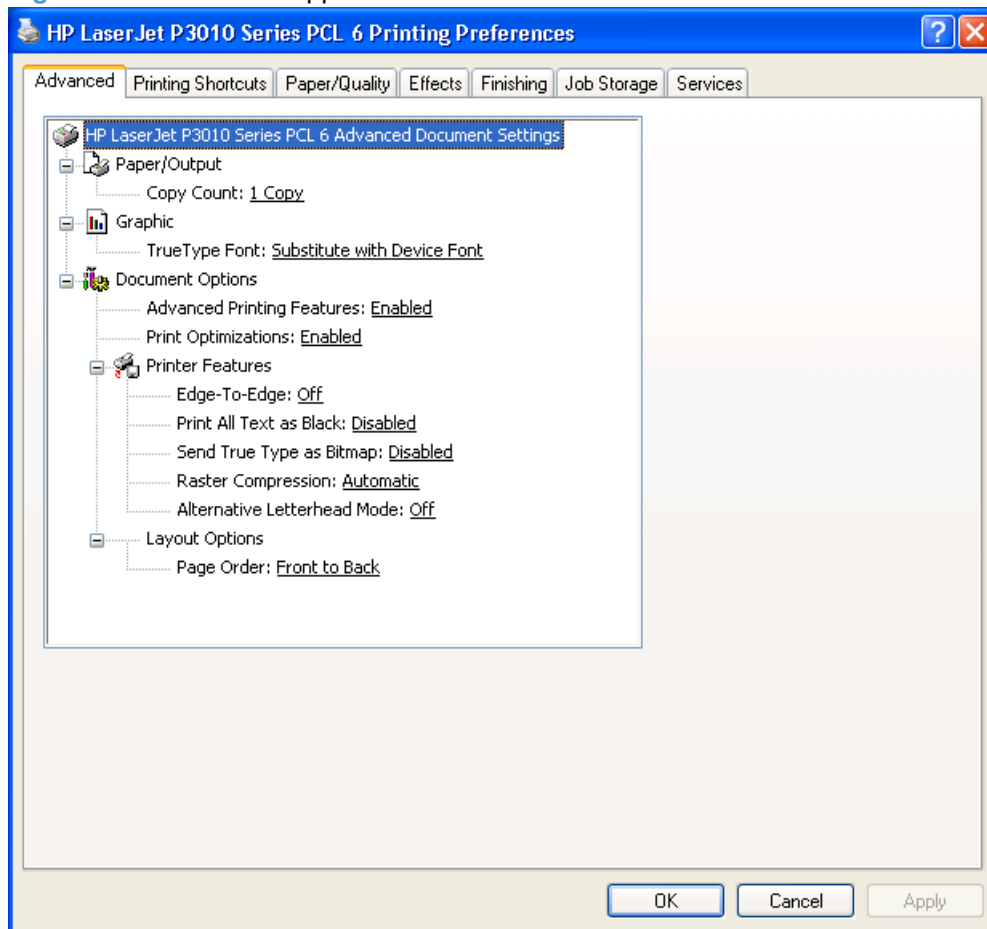

The **Advanced** tab contains the following controls:

- [Paper/Output](#)
- [Graphic](#)
- [Document Options](#)

Paper/Output

The **Paper/Output** control contains the **Copy Count** setting.

Copy Count

Copy Count: Specifies the number of copies to print. This driver setting is useful for software programs that do not provide a copy count. If a copy count is available in the software program, set the copy count in the software program.

The number of copies that you request appears in the **Copy Count** option. You can select the number by typing in the text box or by using the up and down arrows to the right of the text box. Valid entries are numbers from 1 to 9999. The copies value will not advance from the maximum number (9999) to 1 when the up arrow is used, or change from 1 to the maximum number (9999) when the down arrow is used. When you click another group box or leave the **Advanced** tab, invalid entries into the text box (such as non-numerical input, numbers less than 1, or numbers greater than the maximum allowed) are changed to the last valid value that appeared in the text box. The default number of copies is 1.

Because you can set the number of copies that you want from some software programs, conflicts between the software program you are using and the driver can arise. In most cases, the software program and the driver communicate, so that the number of copies set in one location (such as the program) will appear in the other (such as the driver). For some programs, this communication does not take place, and the copies values are treated independently. For these programs, setting 10 copies in the program and then setting 10 copies in the driver will result in 100 copies (10 x 10) being printed. It is recommended that you set the number of copies in the program, whenever possible.

Graphic

The **Graphic** control contains the **TrueType Font** settings.

TrueType Font

Use **Substitute with Device Font** (the default setting) to print documents that contain TrueType fonts by using equivalent printer fonts. This permits faster printing; however, you might lose special characters that the equivalent printer font does not support. Select **Download as Softfont** to download TrueType fonts for printing instead of using printer fonts.

Document Options

The **Document Options** control contains the following settings:

- [Advanced Printing Features](#)
- [Print Optimizations](#)
- [Printer Features](#)
- [Layout Options](#)

Advanced Printing Features

When the **Advanced Printing Features:** setting is **Enabled**, metafile spooling is turned on and **Finishing** tab options such as **Page order:**, **Booklet layout:**, and **Pages per sheet:** are available, depending on your product.

Enhanced metafile spooling is used to greatly reduce the amount of time that elapses between a request to print (initiated by an application) and the return of control to the application by the operating system.

For normal printing, leave the **Advanced Printing Features:** setting at the default (**Enabled**). If compatibility problems occur, you can disable the feature. However, some advanced printing features might still appear in the print driver, even though they have been disabled. If you select an advanced

printing feature in the print driver that has been disabled on the **Advanced** tab, the feature is automatically re-enabled.

Print Optimizations

The default setting for **Print Optimizations:** is **Enabled**. When this feature is enabled and your document contains overlapping text and graphics, the text that is placed on top of a graphic might not print correctly. If the printed output is not correct, you can disable this feature. When this feature is disabled, print optimization features, such as substituting device fonts for TrueType fonts and scanning for horizontal and vertical rules, are turned off.

Printer Features

The **Printer Features** control contains the following settings:

- **Edge-To-Edge**

Select this control to enable printing within 2 mm (0.078 inch) of the edge of the page. This feature is set to **Off** by default.

- **Print All Text as Black**

The feature is **Disabled** by default. When **Enabled** is selected, the driver prints all text as black regardless of the original document text color. Color text is printed as black, except for white text, which remains white. (White text is a reliable method of printing reverse typeface against a dark background.) This setting does not affect graphic images on the page, nor does it affect any text that is part of a graphic.

- **Send TrueType as Bitmap**

Send TrueType as Bitmap: Provides an alternative for software programs that have trouble using TrueType fonts for special graphic aspects such as shading, rotation, or slanting. The setting is **Disabled** (off) by default. The TrueType fonts are converted to Bitmap soft fonts before downloading. The **Enabled** setting causes the driver to send TrueType fonts to the product as outlines, which retains the standard format (outline) of the fonts.

- **Raster Compression**

Use the **Raster Compression:** feature to select the graphics-compression method.

- **Automatic.** The software determines the best compression method to use.
- **Best Quality.** This option forces the software to use a lossless compression method. (Lossless means that no data is lost during compression.)
- **Maximum Compression.** Where applicable, this option requires the software to always use a lossy compression method (some data is lost).

- **Alternative Letterhead Mode**

When selected, this option eliminates the need to flip or reload letterhead or preprinted paper in a tray, whether you are printing on one or both sides of the sheet. Load the paper as you would for printing on both sides. If the product tray has an icon that indicates whether to load paper either face-up or face-down, load the paper in the opposite orientation of that shown. The default setting is **Off**.

When this option is selected, you must use one of the following options in the **Paper type** setting:

- Letterhead
- Preprinted

Layout Options

Layout Options contains the **Page Order:** setting.

Page Order: Specifies the order in which the pages of your document are printed. **Front to Back** (default setting) prints the document so that page 1 prints first. **Back to Front** prints the document so that page 1 prints last.

 **NOTE:** The page-ordering operation works on whole sheets of paper rather than on individual logical pages. Accordingly, if you set **Pages per sheet:** (on the **Finishing** tab) to be greater than 1, the ordering of logical pages on a physical sheet of paper does not change.

Printing Shortcuts tab features

- [Use defined printing shortcuts](#)
- [Create a custom printing shortcut](#)

 **NOTE:** The **Printing Shortcuts** tab is in the **Printing Preferences** tab set. For information about how to gain access to these tabs, see [Printing Preferences driver tabs on page 113](#).

Use the **Printing Shortcuts** tab to store specific combinations of driver settings for easy use.

The following figure shows the **Printing Shortcuts** tab.

Figure 4-3 Printing Shortcuts tab

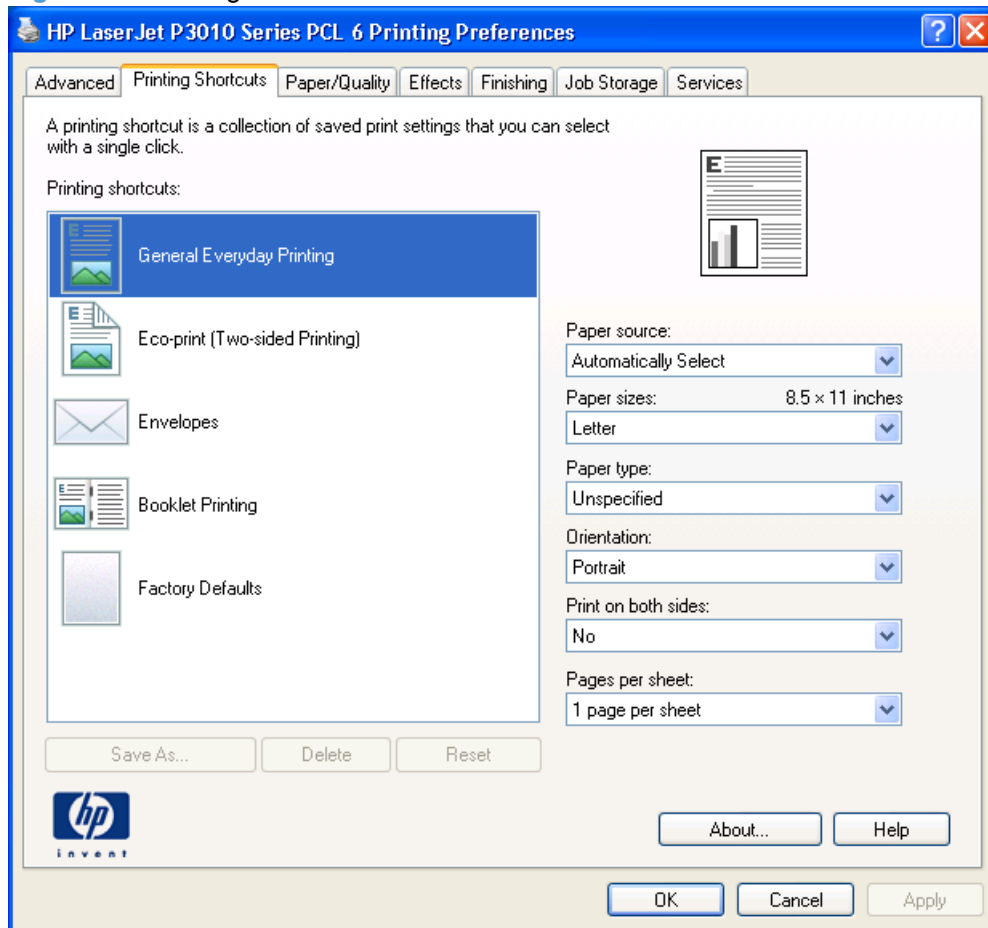

Printing Shortcuts is a new tab that appears on the HP PCL 6 Print Driver beginning with the HP Color LaserJet CM4730 MFP. In previous drivers, the Print Task Quick Sets appeared in most of the driver tabs and was used to capture commonly used driver settings. Like Quick Sets, the **Printing Shortcuts** tab saves commonly used driver settings under a shortcut name.

- [Use defined printing shortcuts](#)
- [Create a custom printing shortcut](#)

Use defined printing shortcuts

The **Printing Shortcuts** tab contains the following control sets:

- [General Everyday Printing](#)
- [Eco-print \(Two-sided Printing\)](#)
- [Envelopes](#)
- [Booklet Printing](#)
- [Factory Defaults](#)

 **NOTE:** Selections (for example, paper types) that are found under the **Printing Shortcuts** tab may include all items found in other driver tabs. The selection list may be shortened under a shortcut for simplification.

General Everyday Printing

When **General Everyday Printing** is selected, the following controls are available:

- **Paper source:**
- **Paper sizes:**
- **Paper type:**
- **Orientation:**
- **Print on both sides:**
- **Pages per sheet:**

When options other than the defaults are selected, the **Save as...** and **Reset** buttons become active.

Click **Save as...** to create a custom printing shortcut.

Click **Reset** to change customized settings back to the default settings.

Paper source

The following options are available:

- **Automatically Select** (default)
- **Printer auto select**
- **Manual Feed in Tray 1**
- **Tray 1**
- **Tray 2**
- **Optional Tray 3** (if installed)
- **Optional Tray 4** (if installed)

Paper sizes

The following options are available:

- **Letter** (default)
- **Legal**

- **Executive**
- **Statement**
- **8.5 x 13**
- **A4**
- **A5**
- **A6**
- **B5 (JIS)**
- **B6 (JIS)**
- **16K 195 x 270mm**
- **16K 197 x 273mm**
- **16K 184 x 260mm**
- **Double Japan Postcard Rotated**

Paper type

The following options are available:

- **Unspecified** (default)
- **Plain**
- **Light 60 - 74g**
- **Labels**
- **Letterhead**
- **Envelope**
- **Preprinted**
- **Prepunched**
- **Colored**
- **Rough**

Orientation

The following options are available:

- **Portrait** (default)
- **Landscape**

Print on both sides

The following options are available:

- **No** (default)
- **Yes, Flip Over**
- **Yes, Flip Up**

Pages per sheet

The following options are available:

- **1 page per sheet** (default)
- **2 pages per sheet**
- **4 pages per sheet**
- **6 pages per sheet**
- **9 pages per sheet**
- **16 pages per sheet**

Eco-print (Two-sided Printing)

 **NOTE:** Because the HP LaserJet P3015, the HP LaserJet P3015d and HP LaserJet P3015n models do not include a duplexing unit, the **Eco-print (Two-sided Printing)** option is available, but duplexing is a manual process.

When **Eco-print (Two-sided Printing)** is selected, the following options are selected.

- **Paper source: Automatically Select**
- **Paper sizes: Letter** (This setting changes according to country/region.)
- **Paper type: Unspecified**
- **Orientation: Portrait**
- **Print on both sides: Yes, flip over**
- **Pages per sheet: 1 page per sheet**

Envelopes

When **Envelopes** is selected, the following options are selected.

- **Paper source: Automatically Select**
- **Paper sizes: Envelope #10**
- **Paper type: Envelope**
- **Orientation: Landscape**

Booklet Printing

When **Booklet Printing** is selected, the following options are selected.

- **Paper source: Automatically Select**
- **Paper sizes: Letter** (This setting changes according to country/region.)
- **Paper type: Unspecified**
- **Orientation: Portrait**
- **Booklet Layout: Left binding**
- **Print document on: Letter**

Factory Defaults

When **Factory Defaults** is selected, the customizable options are unavailable, and the default options are locked in.

The **Factory Defaults** are as follows:

- **Paper source: Automatically select**
- **Paper sizes: Letter** (This setting changes according to country/region.)
- **Paper type: Unspecified**
- **Orientation: Portrait**
- **Print on both sides: No**
- **Pages per sheet: 1 page per sheet**

Create a custom printing shortcut

1. Select **General Everyday Printing** as a base.
2. Select the appropriate print settings on the **Printing Shortcuts** tab or use the settings on any of the **Printing Preferences** tabs.
3. On the **Printing Shortcuts** tab, click **Save As...** The **Printing Shortcuts** dialog box appears.

Figure 4-4 Printing Shortcuts dialog box

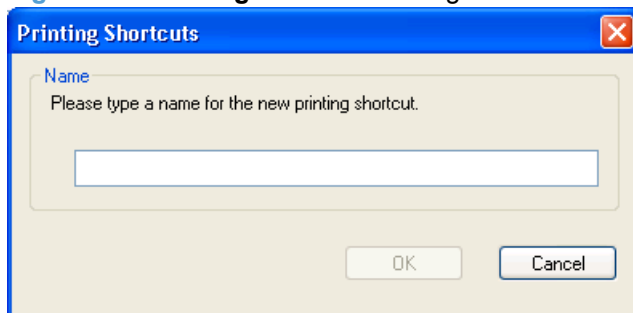

4. Type a name for the custom printing shortcut, and then click **OK**. The custom printing shortcut appears in the **Printing Shortcuts** list.

Figure 4-5 Printing Shortcuts tab—Custom shortcut

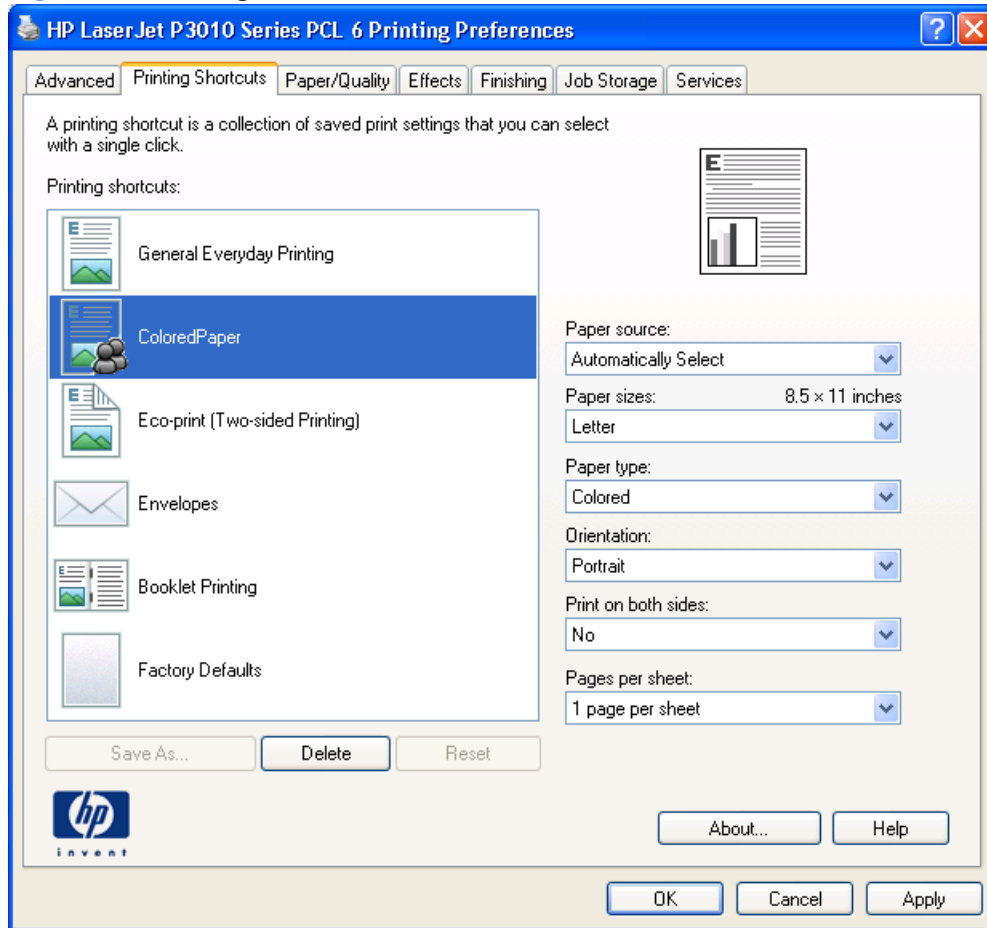

5. To delete a custom printing shortcut, click the custom shortcut, then click **Delete**.

Paper/Quality tab features

 **NOTE:** The **Paper/Quality** tab is in the **Printing Preferences** tab set. For information about how to gain access to these tabs, see [Printing Preferences driver tabs on page 113](#).

Use the **Paper/Quality** tab to specify paper size, type, and source. You can also use this tab to specify different paper selections for the front cover, first page, other pages, last page, and back cover of the document. The following figure shows the **Paper/Quality** tab.

Figure 4-6 Paper/Quality tab

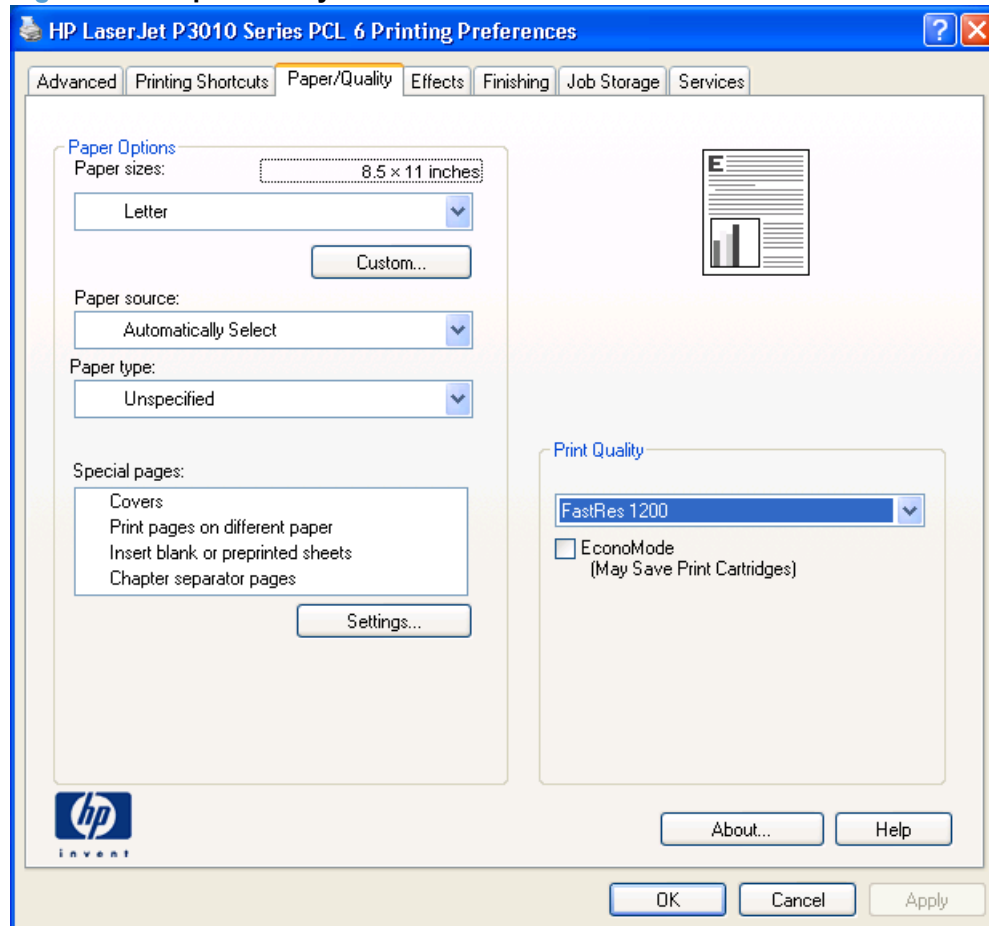

The **Paper/Quality** tab contains the following control sets:

- [Paper Options](#)
- [Document preview image](#)
- [Print Quality](#)

Paper Options

The settings in the **Paper Options** group box on the **Paper/Quality** tab apply to all of the pages of the document. The following figure shows the **Paper Options** group box and the selections that are available by default.

Figure 4-7 Paper Options group box

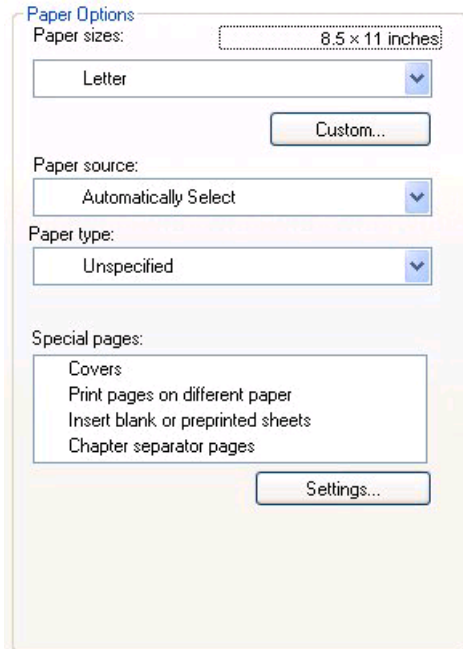

The settings in the **Paper Options** group box are described in the following order:

- [Paper sizes](#)
- [Custom Paper Size](#)
- [Paper source](#)
- [Paper type](#)
- [Special pages](#)

Paper sizes

The **Paper sizes:** drop-down menu lists all of the supported paper sizes.

When you move the mouse over the dimensions label, the mouse cursor changes from an arrow to a gloved hand. Click the dimensions label to toggle between English and metric units.

Because paper-size settings in most software programs override driver settings, it is generally best to use the driver to set the paper size only when you are printing from software programs that do not include a paper-size setting, such as NotePad, or when you are producing a book or a booklet that does not require different paper sizes.

 **NOTE:** Certain software programs can override the size command and specify different paper sizes within a single document.

When you change the print-driver setting to a paper size that is not currently loaded in the product, a control-panel message appears that prompts you to load the paper size or select another tray.

For information about paper sizes, see [Engineering Details on page 205](#).

NOTE: Several **Paper Sizes** are listed in the paper size drop-down menus that are physically too large for the printer, such as 11x17, A3, B4, 8k. These sizes are included for scaling purposes— the printer scales down the printed output from a larger original size used by a software program.

When the settings under the **Special pages:** section have been changed, the **Paper sizes:**, **Paper source:**, and **Paper type:** menus change also, offering a variety of options. For more information, see [Special pages on page 131](#).

Custom Paper Size

The **Custom Paper Size** dialog box appears when you click **Custom...** on the **Paper/Quality** tab. The following figure shows the initial appearance of the **Custom Paper Size** dialog box.

Figure 4-8 Custom Paper Size dialog box

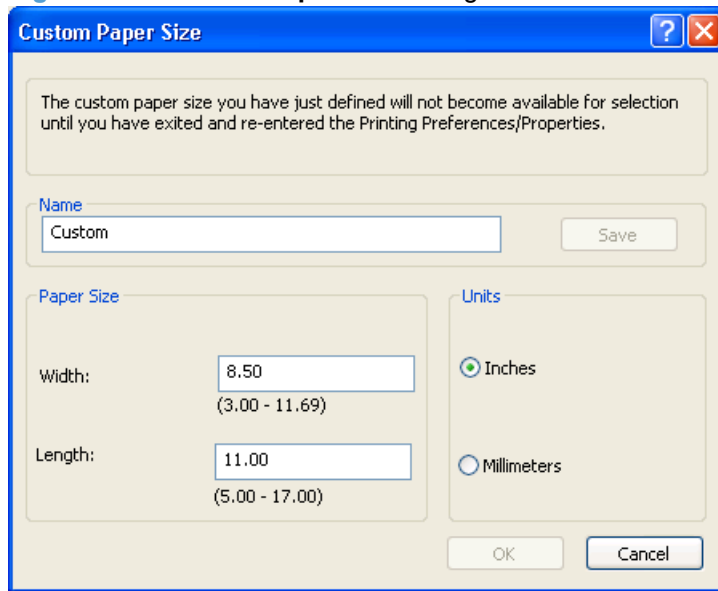

Name

Use the **Name** text box to type a name for a new custom paper size or to rename an existing paper size.

The text that appears in the **Name** text box is one of the following::

- The name of the any custom paper size that is selected on the **Paper/Quality** tab.
- "Custom" if a standard paper size has been selected on the **Paper/Quality** tab.
- Any text that has been typed into the **Name** text box. This text remains in the text box until the new size is saved or the dialog box is closed.

If you type a new name into the **Name** text box but then do not click **Save**, you can change the **Width:** and **Length:** values without losing the name. However, if you close the dialog box without clicking **Save**, any unsaved name or size values are lost without warning.

Paper Size

The **Width:** and **Length:** values can be changed by typing numeric strings into the edit boxes.

Any entry that is too large is rounded down to the maximum valid entry, while any entry that is too small is rounded up to the minimum valid entry.

If units are in millimeters, the custom paper-size range minimum is the limit rounded up to the nearest whole millimeter. The custom paper-size range maximum is the limit rounded down to the nearest whole millimeter. Any non-numerical entry reverts to the last valid entry. Width and length entries are validated when the focus changes.

The resolution of each control is 1/100 of a millimeter or 1/100 of an inch, depending on the current measurement units.

Units

To change measurement units, click one of the options in the **Units** group box (either **Inches** or **Millimeters**).

Custom width and height control limits

The minimum paper size for this product is 98.4 x 148.0 mm (3.87 x 5.83 in) and the maximum is 215.9 x 355.6 mm (8.5 x 14.0 inches). The following table summarizes paper size limits for each paper-handling device.

Table 4-1 PCL 6 custom paper sizes

Tray	Dimensions	Minimum	Maximum
Tray 1 (100-sheet multipurpose)	Width	98.4 mm (3.87 inches)	215.9 mm (8.5 inches)
	Height	148.0 mm (5.83 inches)	355.6 mm (14.0 inches)
Tray 2 (250-sheet), and the optional Trays 3 and 4 (500-sheet)	Width	148.0 mm (5.83 inches)	215.9 mm (8.5 inches)
	Height	210.0 mm (8.27 inches)	297.0 mm (11.69 inches)
Duplexer	Width	148.0 mm (5.83 inches)	215.9 mm (8.5 inches)
	Height	152.4 mm (6.00 inches)	355.6 mm (14.0 inches)

Paper source

The **Paper source**: setting specifies the source tray to use for printing a document. The list of source trays depends on the product accessories that are installed. Any optional source trays that are installed through the **Device Settings** tab also appear here.

The **Paper source**: drop-down menu can contain the following options, depending on what has been installed on the product:

- **Automatically Select**
- **Printer Auto Select**
- **Manual Feed in Tray 1**
- **Tray 1** (100-sheet multipurpose tray)
- **Tray 2** (250-sheet tray)
- **Tray 3** (500-sheet tray), if installed
- **Tray 4** (500-sheet tray), if installed

The default setting is **Automatically Select**. When this setting is selected, the product uses the source tray that supports the paper size that you have selected. If you select a setting other than **Automatically Select**, make sure that the correct paper size is loaded in the source tray. For information about paper sources, see [Engineering Details on page 205](#).

Paper type

The **Paper type**: drop-down menu contains two selections: **Unspecified** and **More**.

The default setting, **Unspecified**, uses the default paper type, which is usually **Plain**.

Selecting **More** opens the **Type is:** dialog box.

Figure 4-9 Type is: dialog box

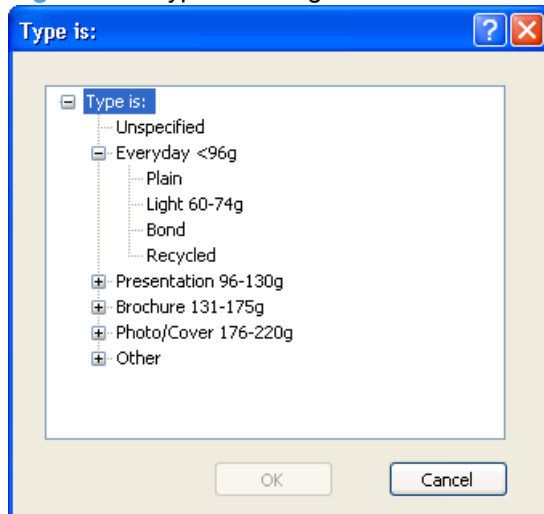

The **Type is:** dialog box contains the following paper types:

- **Unspecified**
- **Everyday <96g**
 - **Plain**
 - **Light 60–74g**
 - **Bond**
 - **Recycled**
- **Presentation 96–130g**
 - **Mid-Weight 96–110g**
 - **Heavy 111–130g**
- **Brochure 126–175g**
 - **Extra Heavy 131–175g**

- **Photo/Cover 176–220g**
 - **Cardstock 176–220g**
- **Other**
 - **Monochrome Laser Transparency**
 - **Labels**
 - **Letterhead**
 - **Envelope**
 - **Preprinted**
 - **Prepunched**
 - **Colored**
 - **Rough**

No mechanism exists for manually adding custom paper types through the driver. Custom types can be added only through the bidirectional communication mechanism, so they must already exist in the product when the bidirectional query occurs. If bidirectional communication is enabled, then the information on an updated list of paper types is returned. If bidirectional communication is not enabled, then the driver looks for custom paper types that have been saved from a previous bidirectional communication query, and uses those. Otherwise, no custom paper types are available through the driver.

The default setting is **Unspecified**, and the program selects the paper type. If you select a different setting, make sure that the correct paper type is loaded in the tray that you selected in the **Paper source:** setting. For more information about paper types, see [Engineering Details on page 205](#).

When you change the print-driver setting to a paper type that is not currently loaded in the product, a control-panel message appears that prompts you to load the paper type or select another tray.

Special pages

To specify special pages to be used, click the **Settings...** button under **Special pages:**.

Covers

To specify cover settings, click **Covers** on the **Special pages:** window, then click **Settings....**

Use the **Covers** options to include a blank or preprinted cover on a document or to include a front/back cover from a source tray that is different from the one used for the remainder of the document.

The following are the **Covers** options:

- **Add a blank or preprinted cover:** Select which cover is customized: **Front**, **Back**, or **Both**.
- **Paper source:** This setting specifies the source tray to use for adding a front and/or back cover to the document. The list of source trays depends on the accessories that are installed. Any optional trays that are installed through the **Device Settings** tab also appear here.
- **Paper type:** This setting specifies the paper size to use for front and/or back covers. Changes made to the **Paper type:** setting here override any previous **Paper type:** settings that use the same paper source.

 **NOTE:** The **Back Cover** options are not available when the **Booklet layout:** setting is enabled on the **Finishing** tab. The **Back Cover** setting is unavailable, because this page would be printed in the middle of a booklet.

NOTE: The same size of paper will be used for the entire print job.

When you change the type and source of the paper and covers, the settings remain configured until you quit the software program.

Print pages on different paper

Use the **Print pages on different paper** options to select an alternative paper type or source for the first or last page of a document.

The following figure shows the **Print pages on different paper** settings and options.

Figure 4-10 Print pages on different paper—First or Last

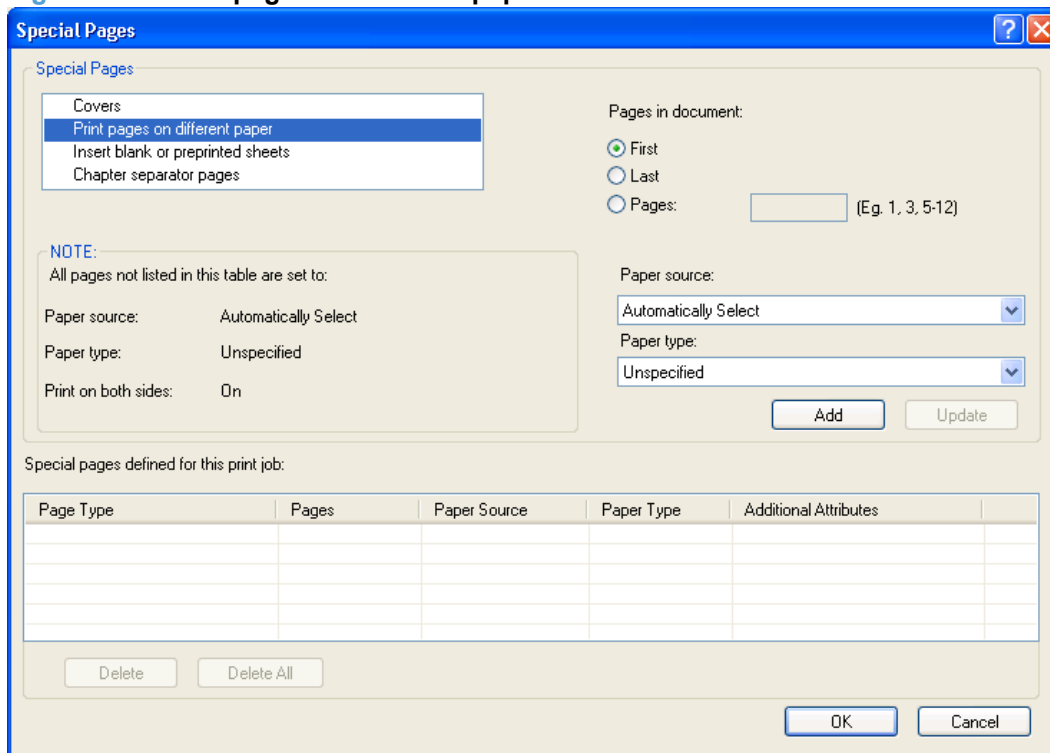

The following are the **Print pages on different paper** options:

- **Pages in document:** Select which pages are customized: the **First** page, the **Last** page, or **Pages:** to select a range of pages or non-sequential, individual pages.
- **Paper source:** This setting specifies the source tray to use for printing a document. The list of source trays depends on the accessories that are installed. Any optional trays that are installed through the **Device Settings** tab also appear here.
- **Paper type:** This drop-down menu shows all of the paper types that the product supports.

 **NOTE:** The same type of paper is used for the entire print job.

When you change the type and source of the paper and covers, the settings remain configured until you close the software program.

Insert blank or preprinted sheets

Use the **Insert blank or preprinted sheets** option to specify the page numbers where blank or preprinted sheets are to be inserted. **Paper Source:** and **Type:** can also be selected.

Chapter separator pages

Use the **Chapter separator pages** option to insert separator pages between chapters. **Paper Source:** and **Type:** can also be selected.

Document preview image

The document preview image is a line-drawn image of a page that represents graphics and text. The document preview image is always oriented so that the contents of the page are right-side-up. The document preview image appears in the upper-right corner of the following **Printing Preferences** driver tabs:

- **Printing Shortcuts**
- **Paper/Quality**
- **Effects**
- **Finishing**

Switching between tabs does not change the location or appearance of the document preview image. When you move the mouse over the document preview image, the mouse cursor changes from an arrow to a gloved hand. You can toggle between portrait and landscape page orientation by clicking the image.

Print Quality

The Print Quality section contains the following controls:

- [Print Quality drop-down menu](#)
- [EconoMode check box](#)

Print Quality drop-down menu

Use this control to select a print quality. Numeric values are in dots per inch (dpi).

The **Print Quality** drop-down menu contains the following resolution options.

- **FastRes 1200.** Prints using 1200 x 600 resolution, is faster than full 1200 x 1200 resolution, but has slightly lower print quality.
- **ProRes 1200.** Prints using 1200 x 1200 resolution, prints slower than the other resolutions, but has the best print quality.
- **600 dpi.** Prints using standard 600 dpi resolution.

EconoMode check box

Click the EconoMode check box to allow the printer to use less toner/ink on each page. This extends the life of your print cartridge and reduces your cost per page, but it reduces print quality. This option may work only if a genuine HP print cartridge is installed. HP print cartridges are able to measure the life of the mechanical parts as well as the toner/ink. When Economode is used a lot the mechanical

parts may wear out before the toner/ink does. This may result in toner/ink spillage, which could damage your printer. Using genuine HP print cartridges avoids this problem.

Effects tab features

NOTE: The **Effects** tab is in the **Printing Preferences** tab set. For information about how to gain access to these tabs, see [Printing Preferences driver tabs on page 113](#).

Use the **Effects** tab to create unique paper effects such as scaling and watermarks. The following figure shows the **Effects** tab.

Figure 4-11 Effects tab

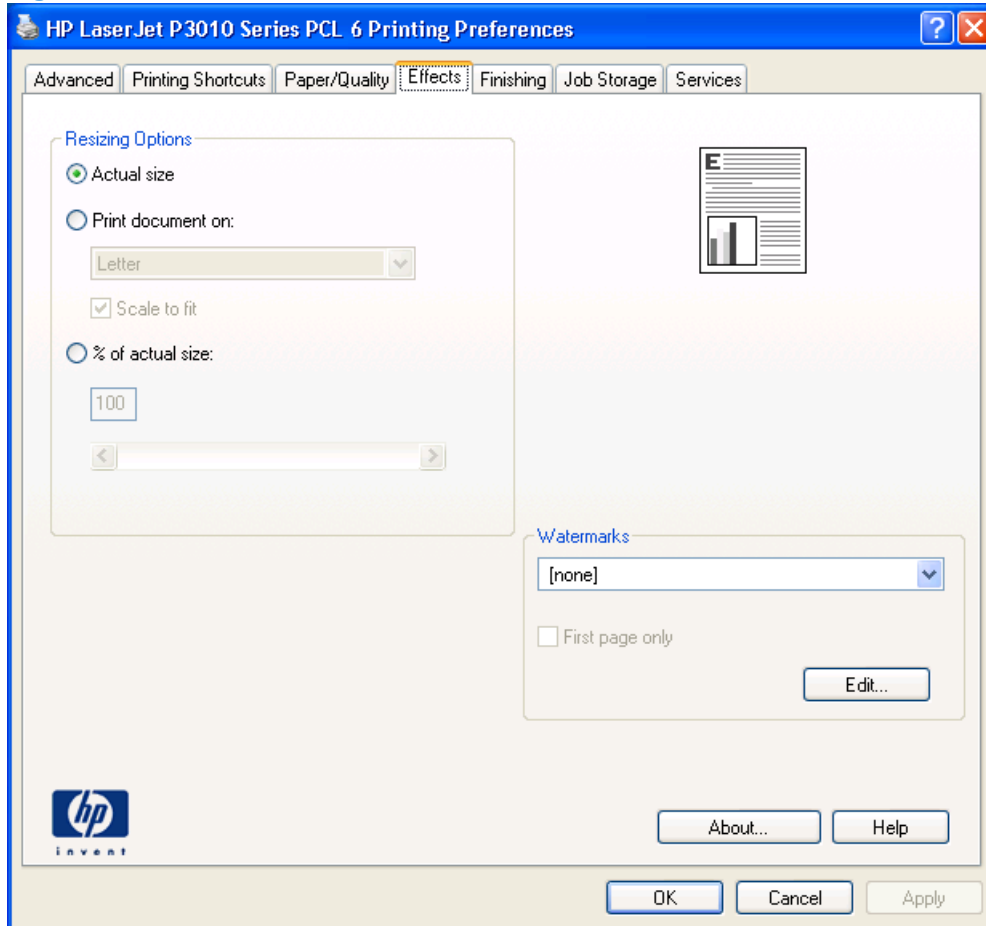

The **Effects** tab contains the following controls:

- [Resizing Options](#)
- [Document preview image](#)
- [Watermarks](#)

Resizing Options

The **Resizing Options** group box consists of the following controls:

- **Actual size** (default)
- **Print document on:**

- **Scale to fit**
- **% of actual size:**

Actual size

Actual size is the default setting. It prints the document without changing the document size.

Print document on

Click the **Print document on:** option to format the document for one paper size and then print the document on a different paper size, with or without scaling the image to fit the new paper size.

Print document on: control is disabled by either of the following conditions:

- The **% of actual size:** value is selected.
- The **Pages per sheet:** value (on the **Finishing** tab) is not 1.

When **Print document on:** is selected, the drop-down menu shows the paper sizes on which you can print. The list contains all of the standard paper sizes that the selected paper source supports and any custom sizes that you have created. When **Print document on:** is selected, **Scale to fit** is automatically selected. Clear this check box if you do not want your document reduced or enlarged to fit on the selected paper.

Scale to fit

The **Scale to fit** option box specifies whether each formatted document page image is scaled to fit the target paper size. By default, **Scale to fit** is selected when **Print document on:** is selected. If the setting is turned off, then the document page images will not be scaled and are instead centered at full size on the target paper. If the document size is larger than the target paper size, then the document image is clipped. If it is smaller, then it is centered within the target paper. The following figure shows the effect that **Scale to fit** has on a document formatted for Legal-size paper but printed on Letter.

Figure 4-12 Preview images – Legal on Letter; **Scale to Fit** off (left) and on (right)

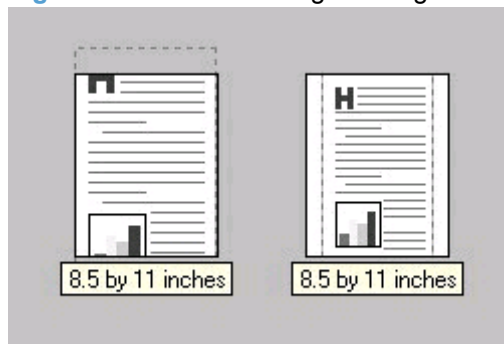

When the size for which the document is formatted (that is, the logical size) differs from the target size, the preview image uses a dashed gray line to show the boundaries of the logical page in relation to the target paper size.

% of actual size

The **% of actual size:** option provides a slider bar for scaling the percentage setting. The default setting is 100%. Actual size is defined as the paper size that is selected within the driver or the size that the driver receives from the software program (if the software program does not negotiate the paper size with the driver). The driver scales the page by the appropriate factor and sends it to the product.

The limits of the range are from 25% to 400%, and any values outside the range are adjusted to those limits as soon as the focus is removed from the control (that is, when the Tab key is pressed or another control is selected).

Any change to the scale also changes the page preview, which increases or decreases from the upper-left corner of the preview.

The slider bar controls the scale directly. The value in the edit box changes as the slider bar is dragged, and the document preview image is updated to the new image scale. Each click on the arrows increases or decreases the scale by 1%. Each click on the slider bar affects the scale by 10%.

To achieve an exact scaling value, either use the slider bar to approximate the value that you want and then use the arrows to refine the value, or type the value into the edit box.

The following settings disable **% of actual size**:

- **Print document on:** (on the **Effects** tab) is selected
- **Pages per sheet:** (on the **Finishing** tab) is not 1

Document preview image

The document preview image is a line-drawn image of a page that represents graphics and text. The document preview image is always oriented so that the contents of the page are right-side-up. The document preview image appears in the upper-right corner of the following **Printing Preferences** driver tabs:

- **Printing Shortcuts**
- **Paper/Quality**
- **Effects**
- **Finishing**

Switching between tabs does not change the location or appearance of the document preview image. When you move the mouse over the document preview image, the mouse cursor changes from an arrow to a gloved hand. You can toggle between portrait and landscape page orientation by clicking the image.

Watermarks

Use the **Watermarks** feature to select a watermark, create a new watermark (text only), or edit an existing watermark. The following watermarks are preset in the driver:

- **(none)**
- **Confidential**
- **Draft**
- **SAMPLE**

The drop-down menu shows alphabetically sorted watermarks that are currently available on the system, plus **(none)** which indicates that no watermark is selected. This is the default setting. Any watermark that is selected from this list appears in the preview image.

When the **First page only** check box is selected, the watermark is printed only on the first page of the document. The **First page only** check box is disabled when the current watermark selection is **(none)**.

Watermarks are applied to logical pages. For example, when **Pages per sheet:** is set to **4** and **First page only** is turned off, four watermarks appear on the physical page (one on each logical page).

Click **Edit**, and the **Watermark Details** dialog box appears.

Figure 4-13 Watermark Details dialog box

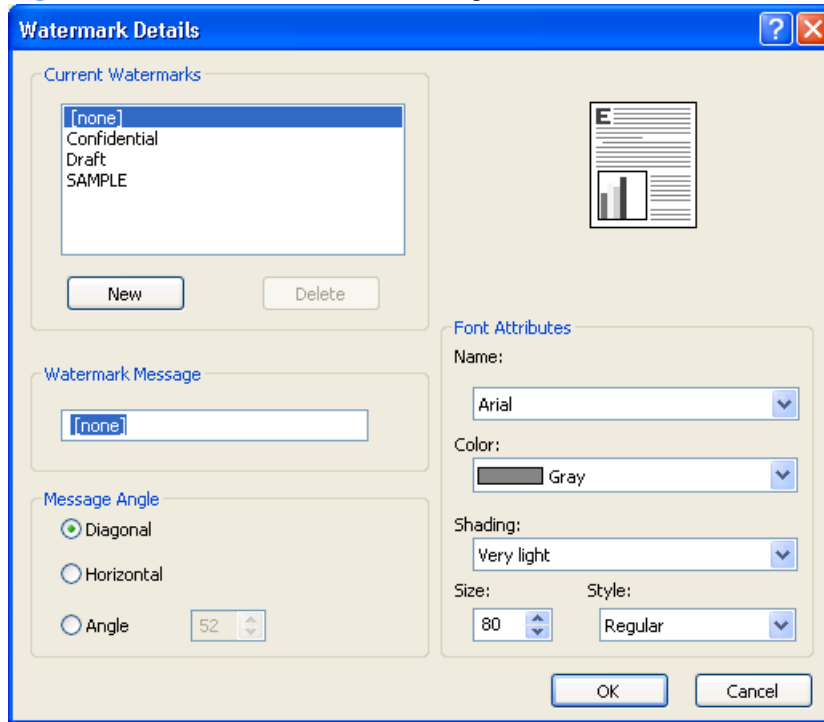

The dialog box shows a preview image and provides options for creating a new watermark and controlling the message angle and font attributes.

Click **OK** to accept all of the changes that are made in the **Watermark Details** dialog box. However, clicking **Cancel** does not cancel all of the changes. If you make changes to a watermark and then select a different watermark or click **New**, all of the changes are saved, and only the current, unsaved changes can be canceled.

Current Watermarks

The **Current Watermarks** group box contains a list of available watermarks, both predefined watermarks that are available in the driver and any new watermarks that you have created.

To create a new watermark, click **New**. The new watermark appears in the **Current Watermarks** list and in the **Watermark Message** edit box as "**Untitled**" until you type a new name in the **Watermark Message** edit box. The new name then appears in the **Current Watermarks** group box, in the **Watermark Details** dialog box, and in the **Watermarks** group box on the **Effects** tab.

To delete a watermark, select the watermark in the **Current Watermarks** list and click **Delete**. At the warning that appears, click **Cancel** to keep the watermark, or click **OK** to delete it.

 **NOTE:** When you reach the limit of 30 watermarks in the **Current Watermarks** list at one time, the **New** button is disabled.

To edit an existing watermark, select the watermark in the **Current Watermarks** list. If you change the **Watermark Message** for that watermark, you are, in effect, creating a new watermark.

Watermark Message

The **Watermark Message** is also the name that identifies the watermark in the **Current Watermarks** list, except when more than one watermark has the same message. For example, you can have several different watermarks with the message DRAFT, each with a different typeface or font size. When this occurs, the string is appended with a space, a pound sign, and a number (for example, **Draft #2**). When a number is added, the number 2 is used first, but if the resulting name is also in the list, then the number increases until the name is unique (**Draft #3**, **Draft #4**, and so on).

Message Angle

Use the controls in the **Message Angle** group box to print the watermark in different orientations on the page. All settings center the watermark string within the page; the selection of a particular setting affects only the angle of the string placement. The following settings are available:

- **Diagonal.** This is the default setting. Select this setting to place the text along a line that spans the lower-left to upper-right corners of the page.
- **Horizontal.** Select this setting to place the text along a line that spans the mid-left and mid-right edges of the page.
- **Angle.** Select this setting to place the text at the specified angle across the page. Use the numeric spin box to select the angle.

Font Attributes

Use the controls in the **Font Attributes** group box to change the font and the shading, size, and style of the font.

The **Font Attributes** group box contains the following controls:

- **Name**

The **Name:** drop-down menu lists fonts that are currently installed on the system. The default is language dependent.

- **Shading**

The default **Shading:** setting for new and preset watermarks is **Very light**. The following range of shades is available from the **Shading** drop-down menu:

- **Lightest**
- **Very light** (default)
- **Light**
- **Medium light**
- **Medium**
- **Medium dark**
- **Dark**
- **Very dark**
- **Darkest**

These values represent the intensity of the gray that is used. **Light** produces a lightly saturated gray watermark, **Lightest** produces the lightest shade of watermark, and **Darkest** produces a black watermark.

- **Size**

Font sizes from 1 to 999 points are available from the **Size** menu. The default point size is language dependent.

- **Style**

The following settings are available:

- **Regular**
 - **Bold**
 - **Italic**
 - **Bold Italic**
- The default **Style**: setting for new and preset watermarks is **Regular**.

Default watermark settings

The following table shows **Font Attribute** settings for new and preset watermarks.

Table 4-2 Font Attribute settings for new and preset watermarks

Setting	New watermark	Preset watermark
Name	Arial	Varies by language
Shading	Very light	Very light
Size	80	Varies by language
Style	Regular	Regular

Click **OK** to accept all of the changes that have been made in the **Watermark Details** dialog box. Clicking **Cancel** does not cancel all of the changes. If you make changes to a watermark and then select a different watermark or click **New**, all of the changes are saved, and only the current, unsaved changes can be canceled.

Finishing tab features

 **NOTE:** The **Finishing** tab is on the **Printing Preferences** tab set. For information about how to gain access to these tabs, see [Printing Preferences driver tabs on page 113](#).

Use the **Finishing** tab to print booklets and control the paper output. The following figure shows the **Finishing** tab.

Figure 4-14 Finishing tab

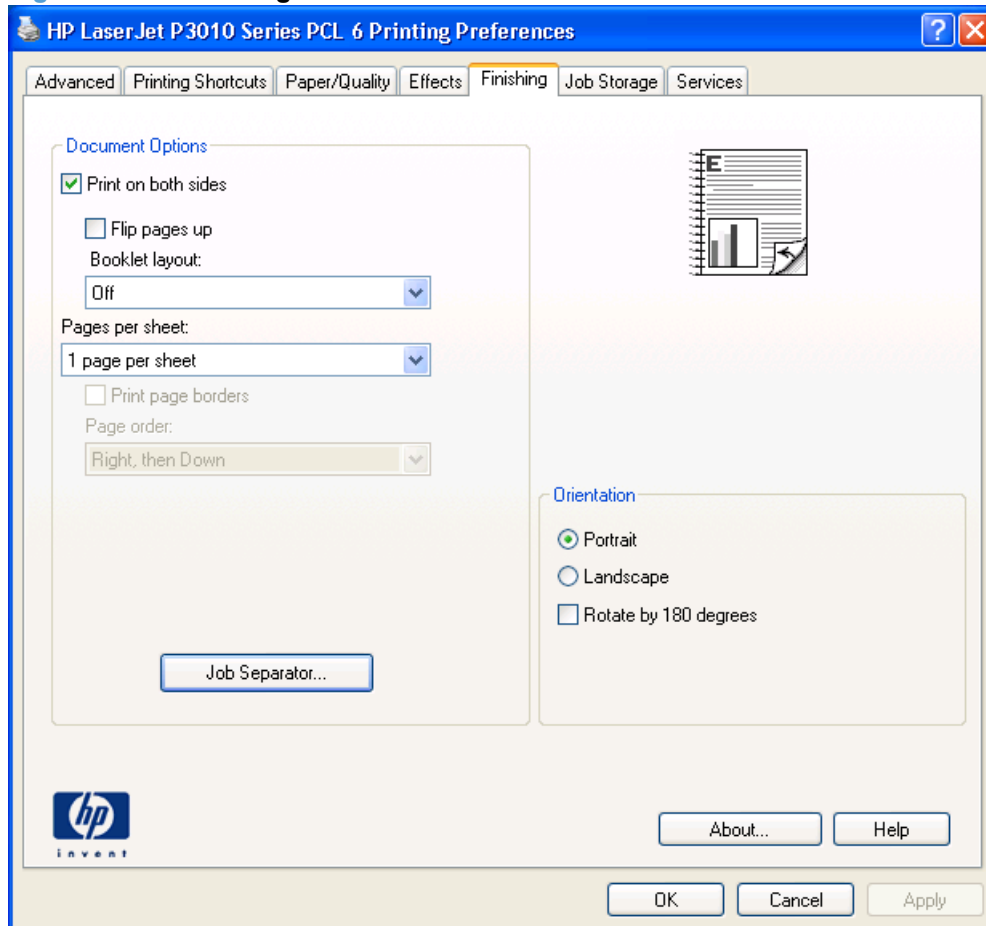

The **Finishing** tab contains the following controls:

- [Document Options](#)
- [Job Separator](#)
- [Document preview image](#)
- [Orientation](#)

Document Options

The **Document Options** group box contains the following controls:

- [Print on both sides](#)
- [Flip pages up](#)

- [Booklet layout](#)
- [Pages per sheet](#)
- [Print page borders](#)
- [Page order](#)

Print on both sides

 **NOTE:** This feature is called **Print on Both Sides (manually)** for the HP LaserJet P3015, the HP LaserJet P3015d, and the HP LaserJet P3015n, because these models do not include an automatic duplex unit. For all other product models, this feature is called **Print on Both Sides**.

The default setting for **Print on both sides** is off (not selected). **Print on both sides** is available when the following conditions exist:

- **Paper type:** on the **Paper/Quality** tab is set to any paper type *except for* the following types:
 - **Labels**
 - **Monochrome Laser Transparency**
 - **Envelope**
 - **Cardstock 176–220g**
- **Paper sizes:** is set to any paper size *except for* the following sizes:
 - **Envelope #10**
 - **Double Postcard (JIS)**
 - **Envelope #9**
 - **Envelope Monarch**
 - **Envelope B5**
 - **Envelope C5**
 - **Envelope C6**
 - **Envelope DL**
 - **Statement**
 - **4x6**
 - **5x8**
 - **A6**
 - **B6**

 **NOTE:** The check box for **Print on both sides (manually)** is not disabled if paper types or sizes that are not allowed for duplexing are selected. However, on the **Paper/Quality** tab next to the paper type or size setting, a caution symbol shows if a selection is not supported by the printer.

Print on both sides (automatically)

The duplexing unit in the HP LaserJet P3010 Series product prints on two sides of a sheet of paper when the **Print on Both Sides** option is specified in the print job. The HP LaserJet P3010 Series product comes with a duplexing unit installed in the following models:

- HP LaserJet P3015dn
- HP LaserJet P3015x

These product models support smart duplexing. The smart duplexing feature increases printing performance by preventing one-page print jobs or single-sided pages of a duplexed print job from going through the duplexing unit even when the duplexing feature has been selected in the driver.

All paper types support the smart duplexing feature, except for paper types that cannot be printed on both sides (such as labels, transparencies, and envelopes) and the following paper types:

- Prepunched
- Preprinted
- Letterhead
- Cardstock

When the paper type is set to **Unspecified**, the smart duplexing feature is disabled.

To achieve the best print quality when printing on the second side of the page, the product needs to make adjustments to its print modes. When you select a paper type, you are, in effect, instructing the product to use a group of settings (such as fuser temperature and print speed) to print the paper with the best possible quality. This group of settings is known as print mode. For the best print quality, a different print mode is used with each paper type. Print-mode adjustments for the second side of a duplexed page are automatic.

Print on both sides manually

Select the **Print on Both Sides (Manually)** check box to print on the second side of the paper for the HP LaserJet P3015, the HP LaserJet P3015d, and the HP LaserJet P3015n, because these models do not include an automatic duplex unit. Also, select **Print on Both Sides (Manually)** on the other HP LaserJet P3010 Series product models for paper types that are not available when using the automatic duplexing unit, such as cardstock and thick paper.

Manually printing on the second side of a page is available when you are using the HP PCL 6 driver. If a duplexing unit is installed and manual duplexing is enabled in the driver, the product automatically prints on both sides of paper types that are supported for automatic duplexing (Letter, A4, Legal, and 8.5 x 11 only). For paper types that are *not* supported for automatic duplexing, a Help message appears prompting you to configure the driver settings for manual printing on both sides. Manual printing on both sides does not occur automatically.

Select the paper type that corresponds to the paper that you are using for the print job. The following paper types have a different print modes when you manually print on the second side:

- Plain
- Preprinted
- Letterhead
- Prepunched

- Bond
- Recycled
- Colored
- Rough

 **NOTE:** To make the **Print on Both Sides (Manually)** check box available in the document options, select the **Allow Manual Duplexing** option on the **Device Settings** tab in the print-driver **Properties** tab set. See [Installable Options on page 161](#).

If you want to print on both sides manually while using paper that is supported for automatic duplexing, you must select and apply the **Not Installed** setting on the **Allow manual duplexing** option on the **Device Settings** tab.

Cardstock paper can be manually printed on the second side, but no change occurs to the print mode. Transparencies and labels should *never* be manually printed on the second side.

To print a multiple-page document, follow these steps:

1. Select the **Print on Both Sides (Manually)** check box.
2. Click **OK**. The even-number pages of the document print.
3. When the control panel shows the MANUALLY FEED message, insert the stack of paper (on which the even-number pages have been printed) as indicated in the following figure.

Figure 4-15 Print on Both Sides Instructions dialog box

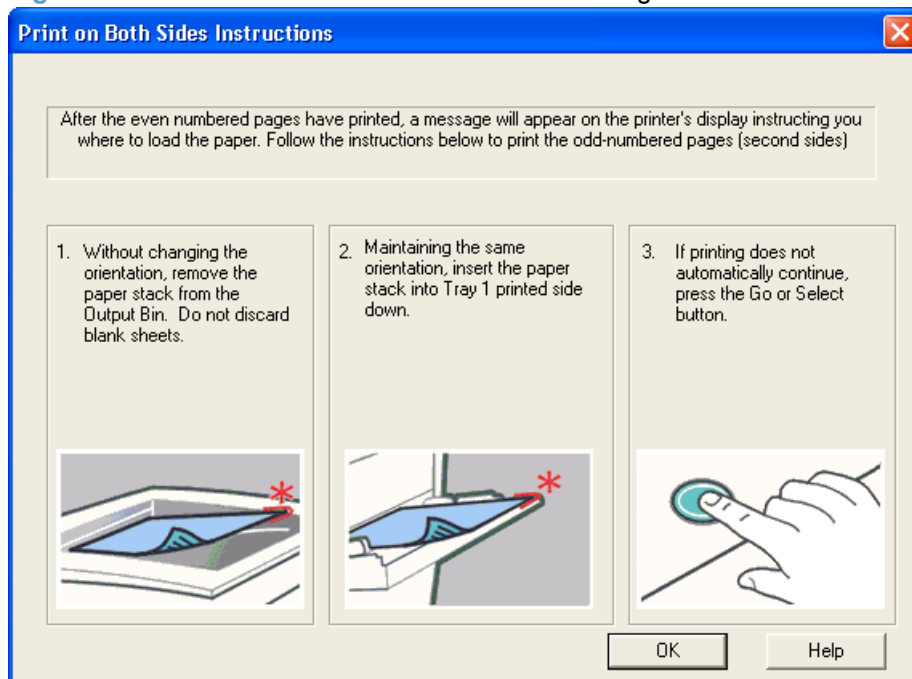

When you have completed the steps that appear in the dialog box, the second half of the print job prints on the back side of the stack of paper. The driver does not require the program to specifically support odd- and even-page printing, because the driver coordinates this function.

Flip pages up

Use the **Flip pages up** check box to specify the duplex-binding option. By default, the **Flip pages up** check box is not available. It is available only when **Print on both sides** is selected. The following table demonstrates the results of selecting this check box, depending on the paper orientation selected on the **Finishing** tab.

Table 4-3 Page orientation

Orientation (Finishing tab)	Flip pages up selected	Flip pages up not selected
Portrait	Short-edge binding	Long-edge binding
Landscape	Long-edge binding	Short-edge binding

When **Print on both sides** is selected, the document preview image changes to show a spiral binding along either the left edge or the top edge of the page. In addition, a folded-over corner appears in the lower-right portion of the preview image, indicating that printing occurs on the back side. An arrow on the folded-over corner points in the direction that the pages would be flipped if they were bound together.

Short-edge binding is for print jobs with pages that read by flipping over like the pages of a calendar. Long-edge binding is for print jobs with pages that read by turning like the pages of a book.

Booklet layout

The **Booklet layout:** drop-down menu, visible when **Print on both sides** is selected, offers choices that are based on the current paper size. The default setting for the **Booklet layout:** drop-down menu is **Off**. The other settings have the following format, where **[paper size]** depends on the paper size that is set on the **Paper/Quality** tab:

- **Left Edge Binding**
- **Right Edge Binding**

When you select **Left Edge Binding** or **Right Edge Binding**, the document preview image changes to show the location of the binding. If the **Pages per sheet:** setting is on the default setting of 1, it automatically changes to **2 pages per sheet**. If you manually change the **Pages per Sheet** setting to 4, 6, 9, or 16 pages per sheet, the **Booklet layout:** is disabled. See [Pages per sheet on page 146](#) for more information.

Book and booklet printing

The product supports book and booklet printing.

A book is a print job consisting of at least two pages. You can use the **Covers** and **Print pages on different paper** settings on the **Paper/Quality** tab to select different paper for the front cover, first page, other pages, and back cover. For more information, see [Paper/Quality tab features on page 126](#).

A booklet is a print job that places two pages on each side of a sheet that can then be folded into a booklet that is half the size of the paper. Use the **Booklet layout:** drop-down menu on the **Finishing** tab to control booklet settings.

 **NOTE:** Booklet folding is a manual process. The product does not fold.

Pages per sheet

Use the **Pages per sheet:** option to select the number of pages that you want to print on a single sheet of paper. If you choose to print more than one page per sheet, the pages appear smaller and are arranged on the sheet in the order that they would otherwise be printed. The **Pages per sheet:** drop-down menu provides the following settings:

- **1 page per sheet** (default)
- **2 pages per sheet**
- **4 pages per sheet**
- **6 pages per sheet**
- **9 pages per sheet**
- **16 pages per sheet**

 **NOTE:** When you select an option other than **2 pages per sheet**, booklet printing is unavailable.

Print page borders

Related controls indented beneath **Pages per sheet:** are **Print page borders** and **Page order:**, which become active when **Pages per sheet:** is greater than 1.

Print page borders sets a line around each page image on a printed sheet to help visually define the borders of each logical page.

Page order

The **Page order:** drop-down menu contains the following options:

- **Right, then Down**
- **Down, then Right**
- **Left, then Down**
- **Down, then Left**

The preview document image reflects changes in these settings, as shown by the examples in the following figure.

Figure 4-16 Page-order preview images

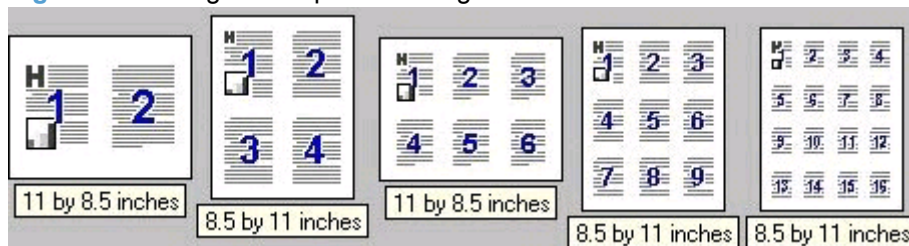

- **2 pages per sheet**
- **4 pages per sheet**
- **6 pages per sheet**

- **9 pages per sheet**
- **16 pages per sheet**

Job Separator

Click the **Job Separator...** button to insert a separator page between print jobs. The **Separator Page Details** dialog box allows you to enable job separation, select the paper source and paper type for the separator page, and specify information to include on the page.

Figure 4-17 Separator Page Details dialog box

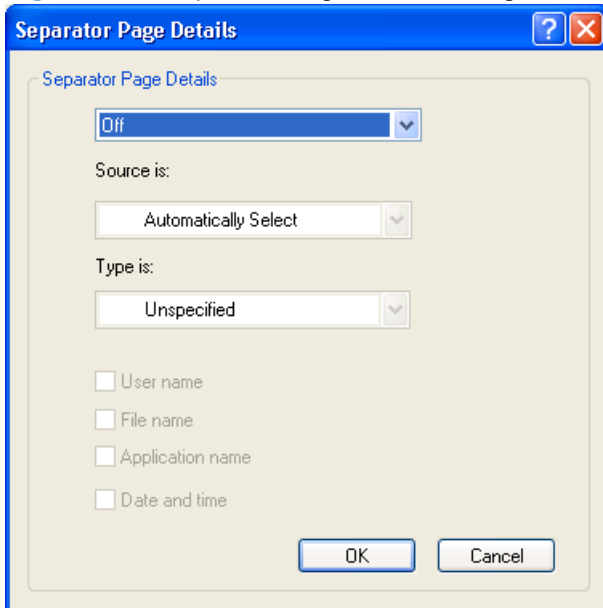

Select **Separator page** from the first drop-down menu. The default setting is **Off**.

Select a paper source for the separator page from the **Source is:** drop-down menu.

Select a paper type from the **Type is:** drop-down menu.

Select any information to be printed on the separator page. The available options are **User name**, **File name**, **Application name**, and **Date and time**.

Document preview image

The document preview image is a line-drawn image of a page that represents graphics and text. The document preview image is always oriented so that the contents of the page are right side up. The document preview image appears in the upper-right corner of the following **Printing Preferences** driver tabs:

- **Printing Shortcuts**
- **Paper/Quality**
- **Effects**
- **Finishing**

Switching between tabs does not change the location or appearance of the document preview image. When you move the mouse over the document preview image, the mouse cursor changes from an arrow to a gloved hand. You can toggle between portrait and landscape page orientation by clicking the image.

Orientation

Orientation refers to the layout of the image on the page and does not affect the way that paper feeds into the product. The orientations that you can specify are portrait, landscape, and rotated. The default orientation is **Portrait**.

 **NOTE:** Because nearly all software programs establish orientation the page orientation in the driver is useful only for the few software programs that do not set it.

The **Orientation** group box contains the following options:

- **Portrait.** The top edge of the document is the shorter edge of the paper.
- **Landscape.** The top edge of the document is the longer edge of the paper.
- **Rotate by 180 degrees.** This creates a landscape or portrait orientation in which the image is rotated 180°. This setting is useful for printing prepunched paper.

You can toggle orientation between portrait and landscape by clicking the document preview image. If you select the **Rotate by 180 degrees** check box, no change occurs in the document preview image.

Job Storage tab features

 **NOTE:** The **Job Storage** tab is located on the **Printing Preferences** tab set. For information about how to access these tabs, see [Printing Preferences driver tabs on page 113](#).

Use the job-storage feature to store print jobs in the HP LaserJet P3010 Series product memory or hard disk for printing at a later time.

The **Job Storage** tab appears among the driver tabs only if the job-storage feature is enabled on the **Device Settings** tab. To support job-storage features for complex jobs, or if you often print complex graphics, print postscript (.PS) documents, or use many downloaded fonts, HP recommends that you install additional memory, install a hard disk, or both. Added memory also gives you more flexibility in supporting job-storage features. A minimum total memory of 288 MB is required to use the **Proof and Hold** and **Personal Job** job-storage features. A hard disk is required to use the **Quick Copy** and **Stored Job** job-storage features.

Job storage features are available in the PCL 6 driver only. Job storage is not available for the PCL 6, PCL 5, or PS Universal Print Drivers.

After a hard disk is installed, the driver must be configured to reflect the changes in the product. If bidirectional communication is enabled in your environment, the Update Now feature can be used to update the drivers. For more information, see [Automatic Configuration on page 161](#).

To configure the drivers manually after installing a hard disk, follow these steps:

1. In Windows Vista, click the **Start** button, click **Control Panel**, click **Hardware and Sound**, and then click **Printers**.

In Windows XP, Windows Server 2003, and Windows Server 2008, click **Start**, click **Settings**, and then click **Printers and Faxes**.

In Windows 2000 Service Pack 3, click **Start**, click **Settings**, and then click **Printers**.

2. Right-click the product name.
3. Click **Properties**.
4. Click the **Device Settings** tab.
5. Select **Installed** for the **Printer Hard Disk** under **Installable Options**, and then select **Installed** in the drop-down menu.
6. Click **OK** to make the printer hard disk and job-storage features available.

You can disable the job-storage feature while leaving the printer hard disk enabled. To disable the job-storage feature, follow these steps:

1. In Windows Vista, click the **Start** button, click **Control Panel**, click **Hardware and Sound**, and then click **Printers**.

In Windows XP, Windows Server 2003, and Windows Server 2008, click **Start**, click **Settings**, and then click **Printers and Faxes**.

In Windows 2000 Service Pack 3, click **Start**, click **Settings**, and then click **Printers**.

2. Right-click the product name.
3. Click **Properties**.

4. Click the **Device Settings** tab.
5. Select **Job Storage**.
6. Select **Disabled** in the **Change 'Job Storage' Setting** dialog box that appears.

If the job-storage feature is enabled (without installing a hard disk but with at least 288 MB of total memory), two **Job Storage Mode** settings are available on the **Job Storage** tab:

- **Proof and Hold**
- **Personal Job**

Two additional **Job Storage Mode** settings become available on the **Job Storage** tab if a hard disk is installed:

- **Quick Copy**
- **Stored Job**

The following figure shows the **Job Storage** tab.

Figure 4-18 Job Storage tab

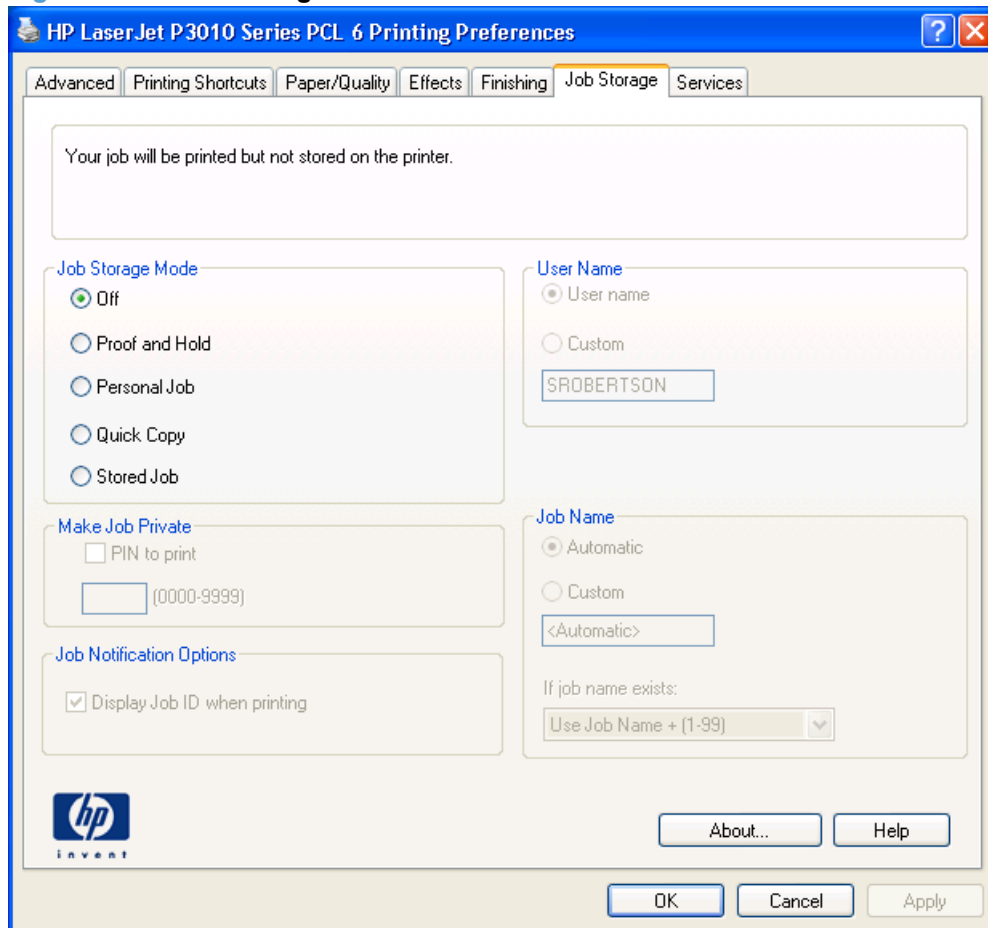

The **Job Storage** tab contains the following controls:

 **NOTE:** Information about using the job-storage feature when printing is also provided here.

- [Status group box](#)

- [Job Storage Mode](#)
- [PIN to print](#)
- [Job Notification Options](#)
- [User Name](#)
- [Job Name](#)
- [Use job-storage features when printing](#)

Status group box

The unlabeled group box on the **Job Storage** tab contains a status message about the destination of a print job. The status information changes depending on the selections that are made on the **Job Storage** tab.

Job Storage Mode

Use the **Job Storage Mode** options on the HP LaserJet P3010 Series product to store documents at the product and then control their printing at the product control panel.

The HP LaserJet P3010 Series product offers the following **Job Storage Mode** options:

- **Off**
- **Proof and Hold** – Prints only the first copy of a print job and holds additional copies until they are requested from the control panel.
- **Personal Job** – Stores a print job on the printer. Printing this stored job requires the print job's personal identification number (PIN). The print job is deleted from memory after it prints.
- **Quick Copy** – Allows additional copies of a print job to be printed from the printer control panel without resending the job from the computer.
- **Stored Job** – Stores a print job on the printer to make it available for printing. The print job is stored on the printer's hard drive (or in memory if available) until it is deleted via the printer control panel.

These options and the settings that control them are described below.

Off

When selected, this option turns the job-storage feature off (it is disabled), which means that the print job will not be stored in the product.

Proof and Hold

To use the **Proof and Hold** option, the job-storage feature must be enabled.

When selected, this option stores the print job in memory and prints only the first copy of the job, allowing you to check the first copy. If the document prints correctly, you can print the remaining copies of the print job at the control panel. You can set the number of proof-and-hold print jobs that can be stored in the product at the control panel.

After it is released for printing, the proof-and-hold job is immediately deleted from the product. If more copies are needed, you must reprint the job from the software program. If you send a second proof-and-hold job to the product with the same user name and job name as an existing proof-and-hold job (and

you have not released the original job for printing), the job overwrites the existing job. Proof-and-hold jobs are deleted if you turn off the product.

 **NOTE:** The product configuration can be set to hold a maximum of 50 quick-copy or proof-and-hold jobs. The number is set at the product control panel in the **CONFIGURATION** menu, and the default is 32. When this preset limit is reached, the new document overwrites the oldest held document. Also, a document that has the same user name and job name as one that is already stored on the printer hard disk will overwrite the existing document.

Personal Job

To use the **Personal Job** option, the job-storage feature must be enabled.

When you select **Personal Job**, the print job is sent to the product, but is not printed until you request the job at the product control panel. Selecting **Personal Job** activates the **PIN** group box. If **PIN to print** is selected, the print job can be printed only after you type the correct PIN at the control panel. After the job is printed, the job is immediately deleted from the product. This feature is useful when you are printing sensitive or confidential documents that you do not want to leave in an output bin after printing.

The Private Job/PIN coupling has a PIN restriction of four ASCII numeric characters (0 through 9). If you type non-numeric characters, they are removed immediately. If you type more than four characters, the characters past the fourth are truncated. The field temporarily accepts fewer than four digits in the string, but when the edit field loses focus, the zeroes pad the left end until the PIN contains exactly four digits. The default initialized value for the PIN is 0000 for **Personal Job**.

After it is released for printing, the private job is immediately deleted from the product. If more copies are needed, you must reprint the job from the software program. If you send a second private job that has the same user name and job name as an existing private job (and you have not released the original job for printing), the job overwrites the existing job, regardless of the PIN. Private jobs are deleted if you turn off the product.

Quick Copy

To use the **Quick Copy** option, a printer hard disk must be installed, and the job-storage feature must be enabled.

When you select **Quick Copy**, the entire print job prints and a copy of the print job is stored on the product, after which you can print additional copies of the print job at the product control panel. The number of quick-copy print jobs that can be stored in the product is set by using the product control panel.

 **NOTE:** The product configuration can be set to hold a maximum of 50 quick-copy or proof-and-hold jobs. The number is set at the product control panel in the **CONFIGURATION** menu, and the default is 32. When this preset limit is reached, the new document overwrites the oldest held document. Also, a document that has the same user name and job name as one that is already stored on the printer hard disk will overwrite the existing document. **Quick Copy** jobs are deleted if you turn off the product.

Stored Job

To use the **Stored Job** option, a hard disk must be installed on the product and the job-storage feature must be enabled.

Use the **Stored Job** option to send a print job directly to the printer hard disk without printing it. The print job is stored in the product as if it is an electronic file cabinet. After the print job is stored on the printer hard disk, you can print the job at the product control panel.

The job remains stored in the product until it is deleted or overwritten by a document that has the same user name and job name. Stored jobs remain on the printer hard disk when the product is turned off. Use this feature for forms and other common or shared documents.

A stored job can be managed in two ways: as either a private or a public job.

Select the **PIN to Print** check box to set the private mode. Use a private stored job to send a print job directly to the product, which can then be printed only after you type a PIN up to 4 digits long at the product control panel. (You can set the PIN in the **PIN** group box.)

After the job is printed, the job remains in the product and can be printed again at the product control panel.

The box labeled **PIN** is usually inactive. The **PIN to Print** option becomes available when you select **Stored Job**. If you select the **PIN to Print** box, you must type a PIN to make the stored job private.

 **NOTE:** A *private* stored job is not the same as a *personal* job. *Personal* jobs are deleted from the product after they are printed. *Private* stored jobs are retained in the product after printing, but require that a PIN be typed each time they are printed. A printer hard disk is required for *Private* stored jobs.

PIN to print

PIN to print check box is available when **Stored Job** is selected. Select the **PIN to Print** box, then type a 4-digit PIN number in the box provided. The stored job is sent to the product, where you must enter the 4-digit PIN on the control panel to retrieve the personal job.

The **PIN to Print** check box is available when **Personal Job** is selected. Select the **PIN to Print** option, and then type a 4-digit PIN number in the box provided. The personal job is sent to the product, where you must type the 4-digit PIN on the control panel to retrieve the stored job.

Job Notification Options

Clicking a **Job Storage Mode** selection causes the **User Name** and **Job Name** options to become available. The **Display Job ID when printing** check box is selected by default. The **Display Job ID when printing** option causes a pop-up dialog box to appear when the job-storage print job is printed. The dialog box shows the user name and job name that are associated with the stored print job, as well as the printer name, port, and location.

User Name

Use the **User Name** settings to help identify the job at the product control panel. The following are the **User Name** settings:

- **User Name.** This option associates your Windows user name with the stored print job. The Windows user name automatically appears in the text field below the **User Name** options.
- **Custom.** Use this option to type a custom name for the stored print job. When you click **Custom**, the text field below the option becomes available. The **User Name** field can contain no more than 16 characters, and is limited to A through Z and 0 through 9 because the name appears on the product control-panel display. If you try to type a lowercase character, it automatically shifts to uppercase. If you try to type a character in an ASCII code of fewer than 32 or more than 126 characters, the character is removed from the edit field, along with all of the characters that follow it. If you try to type more than 16 characters, any character beyond 16 is truncated.

Job Name

Use the **Job Name** options to specify a name to identify the job at the product control panel. The following are the **Job Name** settings:

- **<Automatic>** This option, which is the default selection, automatically generates the job name that is associated with the stored print job. The file name of the print job is used if it is available to the print driver. Otherwise, the software program name or a time stamp is used for the job name.
- **Custom.** Use this to type a custom job name for the stored print job. When you click **Custom**, the text field below the option becomes available. In those languages for which **<Automatic>** cannot be translated without the use of invalid characters, the driver uses a string of three dashes. The acceptable characters for job name and user name vary for each operating system. The string must be of a length and type that can appear on the product control-panel display.

The **Job Name** field can contain no more than 16 characters, and is limited to A through Z (uppercase or lowercase) and 0 through 9 so that the name can appear on the product control-panel display. If you try to type a character in an ASCII code of fewer than 32 or more than 126 characters, the character is removed from the edit field, along with all of the characters that follow it. If you try to type more than 16 characters, any character beyond 16 is truncated.

When the dialog box is closed, or as soon as the focus is removed from the control (that is, when the **Tab** key is pressed or another control is selected), an empty string is replaced with **<Automatic>**. The acceptable characters for job name and user name vary for each operating system. The string must be of a length and type that can appear on the product control-panel display.

If Job Name Exists. When you store a print job, you can create a print-job name or the product software can assign one automatically. If a print job with the same name already exists, the new print job will overwrite the existing print job. To eliminate the chances of a new print job overwriting an old print job because both have the same name, select **Use Job Name + (1-99)**. After you create the print job name, or when one is created automatically, the product software assigns a number between 1 and 99 to the end of the print job name to make the name unique. Select **Replace Existing File** if you always want the product software to overwrite an existing print job with the same print job name.

Use job-storage features when printing

To use job-storage features when printing, follow these steps:

1. Click **File**, and then click **Print** from the software program. The **Print** dialog box appears.

 **NOTE:** Clicking the print icon in the software program toolbar prints the job without using job-storage features.

2. Click **Properties**. The **Properties** dialog box appears.
3. Click the **Job Storage** tab.
4. Select the job-storage options by clicking the appropriate option button, and then complete any required fields.
5. Click **OK**.

Release a job-storage print job

After you send a print job that uses the job-storage feature, you can release the job to print from the product control panel.

1. Press the **menu** button  to open the menus.
2. Press the **up arrow** ▲ or the **down arrow** ▼ until **RETRIEVE JOB** is highlighted on the product control panel, and then press **OK**.
3. Press the **up arrow** ▲ or the **down arrow** ▼ to scroll to your user name, and then press **OK**.
4. Press the **up arrow** ▲ or the **down arrow** ▼ to scroll to the job name, and then press **OK**.
5. Press the **up arrow** ▲ or the **down arrow** ▼ until **PRINT** is highlighted on the product control panel, and then press **OK**.
6. Press **OK**.
7. If a PIN number is assigned to the job, press the **up arrow** ▲ or the **down arrow** ▼ to select the first digit of the PIN, and then press **OK**. The number in the product control-panel display changes to an asterisk. Repeat this step for each of the remaining three digits of the PIN number.

If no PIN number is assigned to the job, continue with the next step.
8. Press the **up arrow** ▲ or the **down arrow** ▼ to select the number of copies to print.
9. Press **OK** to print the job.

Delete a job-storage print job

Sometimes it is necessary to delete a print job from the printer hard disk. You can do this from the product control panel.

1. Press the **menu** button  to open the menus.
2. Press the **up arrow** ▲ or the **down arrow** ▼ until **RETRIEVE JOB** is highlighted on the product control panel, and then press **OK**.
3. Press the **up arrow** ▲ or the **down arrow** ▼ to scroll to your user name, and then press **OK**.
4. Press the **up arrow** ▲ or the **down arrow** ▼ to scroll to the job name, and then press **OK**.
5. Press the **up arrow** ▲ or the **down arrow** ▼ until **DELETE** is highlighted on the product control panel, and then press **OK**.
6. Press **OK**.
7. If a PIN number is assigned to the job, press the **up arrow** ▲ or the **down arrow** ▼ to select the first digit of the PIN, and then press **OK**. The number in the product control-panel display changes to an asterisk. Repeat this step for each of the remaining three digits of the PIN number.

If no PIN number is assigned to the job, continue with the next step.
8. Press **OK** to delete the job.

Services tab features

NOTE: The **Services** tab is on the **Printing Preferences** tab set. For information about how to gain access to these tabs, see [Printing Preferences driver tabs on page 113](#).

The **Services** tab is shown in the following figure.

Figure 4-19 Services tab

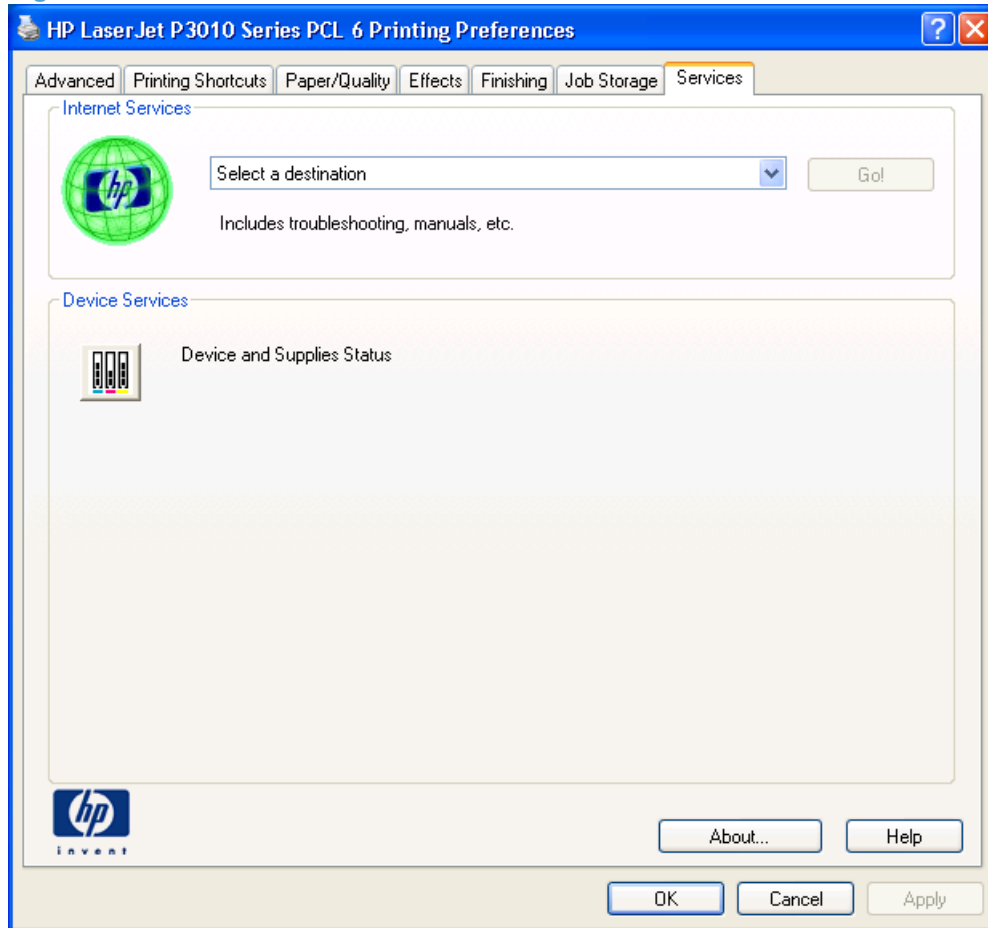

The **Services** tab contains the following group boxes:

- [Internet Services](#)
- [Device Services](#)

Internet Services

The **Internet Services** group box contains the **Select a destination** drop-down menu with the following options:

- **Online diagnostic tools.** This is the HP Instant Support Web site, where you can find interactive tools and contacts for troubleshooting.
- **Support and troubleshooting.** This is the main Web site for product support.
- **Product manuals.** View or download product manuals.

- **Check for driver updates.** Automatically check to see whether the correct and most up-to-date print drivers are installed.
- **Shop for supplies.** Shop online for product supplies.

If you have Internet access, select any of these items and then click **Go!** to open the corresponding HP Web page.

Device Services

Click the **Device and Supplies Status** icon to open the **Device Status** screen of the HP EWS, which shows supply levels and the control-panel status.

Device Settings tab features

NOTE: The **Device Settings** tab is in the **Properties** tab set. For information about how to gain access to these tabs, see [Properties driver tabs on page 114](#).

Available options depend on the feature. The following figure shows the **Device Settings** tab.

Figure 4-20 Device Settings tab

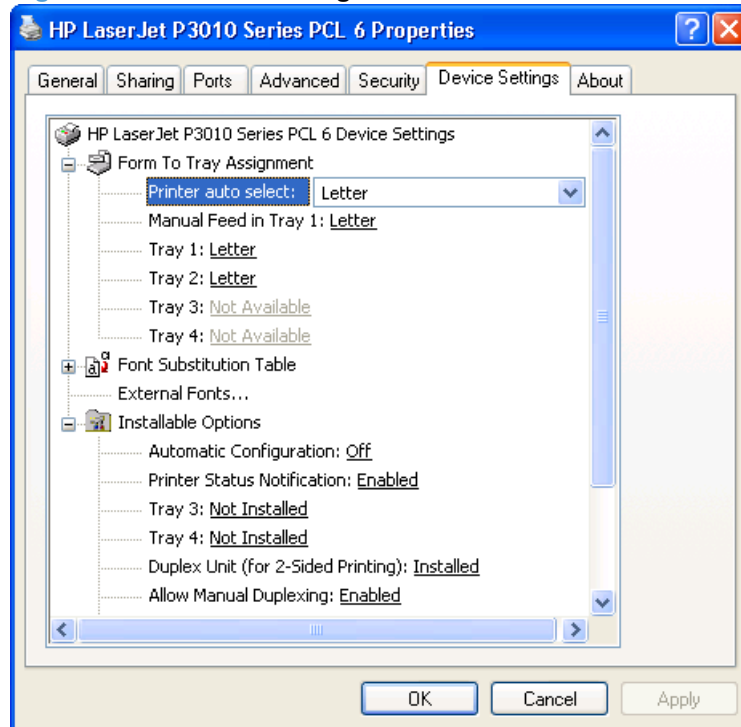

The **Device Settings** tab contains controls for paper-handling devices and controls for managing the product.

The **Device Settings** tab contains the following controls:

- [Form to Tray Assignment](#)
- [Font Substitution Table](#)
- [Installable Options](#)

Form to Tray Assignment

A network administrator can use **Form to Tray Assignment** to specify the paper size in each input tray.

The product supports more than one source of paper. You can assign a form (which defines the paper size and margins) to each paper source. When a form is matched to a source, you can select the form when you print. The product prints from the tray to which that form is assigned.

Network administrators can use the **Form to Tray Assignment** setting to specify, in the driver, the paper size that is loaded into each available input tray. The use of forms constrains the choices that are available in the **Paper-Size** list on the **Paper/Quality** tab in the **Printing Preferences** driver tabs. This constraint reduces the likelihood of tying up the product with paper-mount messages that occur when users request sizes or types that are not available.

The trays listed in **Form to Tray Assignment** include standard trays and optional accessory trays. Generally, items that are installed separately have a separate **Installable Options** setting.

The input trays listed here are also listed as paper sources on the **Paper/Quality** tab.

Configuring the trays

1. Select the appropriate tray in the **Form to Tray Assignment** list.
2. Use the drop-down menu to select the paper size (or form) that is loaded in that tray.
3. Repeat steps 1 and 2 for the remaining trays.
4. Click **OK** to enable your settings, or, if necessary, click **Cancel** to reconfigure all the trays and remove the size and type constraints that have been imposed on the **Paper/Quality** tab.

Font Substitution Table

Use **Font Substitution Table** to change the TrueType-to-product font mapping and to install and remove external fonts for the product through the **External Fonts** option. External fonts can be soft fonts or DIMM fonts.

Click **Font Substitution Table** to open a list of fonts, as shown in the following figure. Use the settings to change the TrueType-to-product font mappings.

Figure 4-21 Font Substitution Table

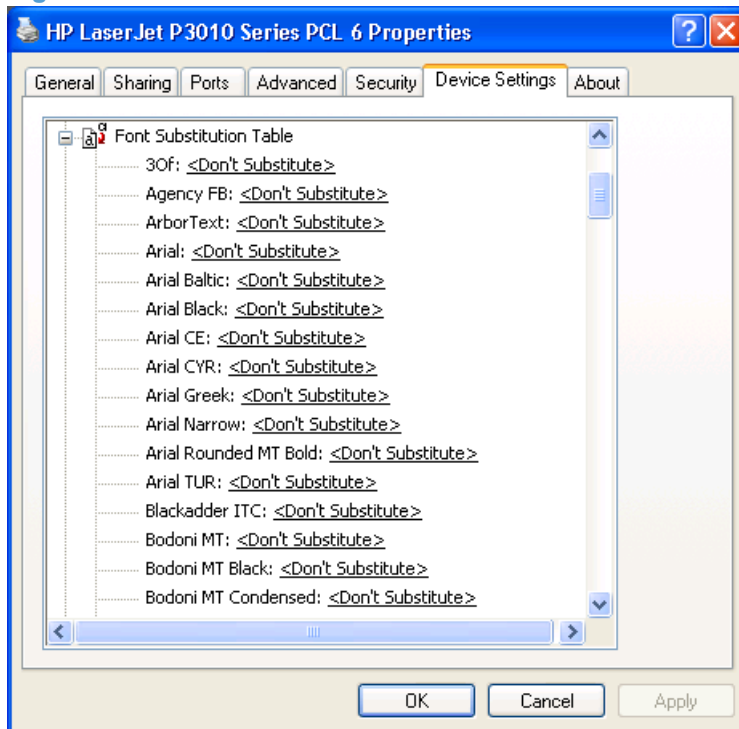

External Fonts

Use **External Fonts** to install and remove external fonts for the product. External fonts can be soft fonts or DIMM fonts.

Click **External Fonts** to make the **Properties** button available. Click **Properties** to open the **HP Font Installer** dialog box, which is shown in the following figure.

Figure 4-22 HP Font Installer dialog box

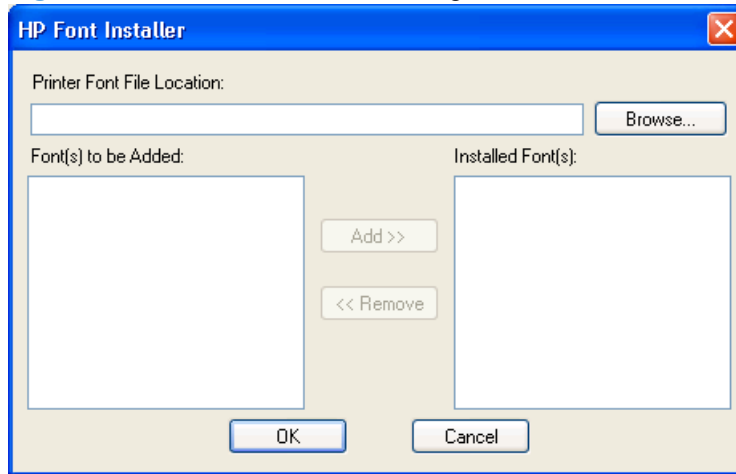

Installing external fonts

Follow these steps to install external fonts.

1. In Windows Vista, click the **Start** button, click **Control Panel**, click **Hardware and Sound**, and then click **Printers**.

In Windows XP and Windows Server 2003, click **Start**, click **Settings**, and then click **Printers and Faxes**.

In **Windows Server 2008**, click **Start**, click **Control Panel**, and then open the **Printers** folder.

In Windows 2000 Service Pack 3, click **Start**, click **Settings**, and then click **Printers**.
2. Right-click the name of the product.
3. Click **Properties**.
4. Click the **Device Settings** tab.
5. Click the **External Fonts** option. The **Properties** button appears.
6. Click **Properties**. The **HP Font Installer** dialog box appears.
7. Type the name and path of the font metric file in the **Printer Font File Location:** text box, or click **Browse...** to locate the file on the computer. The font file names appear in the **Font(s) to be Added:** window.
8. Select the fonts that you want to add, and then click **Add**. The fonts are installed and the file names appear in the **Installed Font(s):** window.
9. Click **OK** to close the **HP Font Installer** dialog box.

Remove external fonts

1. In Windows Vista, click the **Start** button, click **Control Panel**, click **Hardware and Sound**, and then click **Printers**.

In Windows XP and Windows Server 2003, click **Start**, click **Settings**, and then click **Printers and Faxes**.

In **Windows Server 2008**, click **Start**, click **Control Panel**, and then open the **Printers** folder.

In Windows 2000 Service Pack 3, click **Start**, click **Settings**, and then click **Printers**.
2. Right-click the name of the product.
3. Click **Properties**.
4. Click the **Device Settings** tab.
5. Click the **External Fonts** option. The **Properties** button appears.
6. Click **Properties**. The **HP Font Installer** dialog box appears. The external fonts that are installed appear in the **Installed Font(s)** window.
7. Select the fonts that you want to remove, and then click **Remove**. The fonts are removed.
8. Click **OK** to close the **HP Font Installer** dialog box.

Installable Options

Items under **Installable Options** are automatically populated and their defaults set when the driver is installed.

The product has printing options that you can install and configure in this section. The following controls are available:

- [Automatic Configuration](#)
- [Printer Status Notification](#)
- [Tray 3 and Tray 4](#)
- [Duplex Unit \(for 2-Sided Printing\)](#)
- [Allow Manual Duplexing](#)
- [Printer Memory](#)
- [Printer Hard Disk](#)
- [Job Storage](#)
- [Job Separator](#)
- [Mopier Mode](#)

Automatic Configuration

Use the **Device Settings** tab to tell the driver about the hardware configuration of the product. If bidirectional communication is enabled in a supported environment, update this tab by selecting the

Update Now setting in the **Automatic Configuration:** setting. The default setting is **Off**. After an automatic configuration, the setting returns to **Off** after the changes are made.

If your environment does not support bidirectional communication, the **Update Now** setting is unavailable, so you must manually configure the options on this tab.

If you have more than one driver installed for the product (for example, the default HP PCL 6 Print Driver and the HP PS Universal Print Driver), the Update Now feature works only on the driver on which it is activated. The other driver will not be updated and might show the default setting for the specific product model.

Printer Status Notification

When enabled, this option displays a small status-notification window in the lower-right corner of the screen. This window is visible while printing a document or while viewing the printer driver settings. It provides information about the status of the document being printed as well as information about the printer, including the current status of printer supplies.

Tray 3 and Tray 4

These controls specify whether you have Tray 3 or Tray 4, additional 500-sheet trays, installed on the product.

Duplex Unit (for 2-Sided Printing)

The duplexing unit comes installed on the HP LaserJet P3015dn and the HP LaserJet P3015x product models.

 **NOTE:** The HP LaserJet P3010 Series product supports smart duplexing. The product uses the smart duplexing feature to detect information on both sides of the print job pages and only runs the pages through the duplexing unit if printable information appears on the second side of the page.

Allow Manual Duplexing

Select **Allow Manual Duplexing** to print on both sides of any supported size and most types of paper (except transparencies, envelopes, and labels). To use this feature, you must reinsert the paper stack into the input tray to print the second side. The product pauses while you make this adjustment.

This setting is enabled by default.

Printer Memory

Specifies the amount of memory installed in your printing device. The minimum memory requirement is 288 MB for using job storage functions. For some complex print jobs, more memory might be required.

Printer Hard Disk

When this option is installed, the **Job Storage** option and the **Mopier Mode** are enabled in the print driver. Use the **Job Storage** option to store print jobs and then print them later from the control panel. The multiple-original print (mopy) function is an HP-designed feature that produces multiple, collated copies from a single print job.

Job Storage

When **Job Storage** is enabled, the product can store print jobs so that you can gain access to those print jobs later at the control panel.

Job Separator

Use this control to specify whether a print job identifier page should be printed between print jobs.

For more information, see [Job Separator on page 147](#).

Mopier Mode

The multiple-original print (mopy) function is an HP-designed feature that produces multiple, collated copies from a single print job. Multiple-original printing (mopying) increases performance and reduces network traffic by transmitting the job to the product once and then storing it in memory or on the hard disk. The remainder of the copies are printed at the fastest speed. All documents that are printed in mopier mode can be created, controlled, managed, and finished from the computer, which eliminates the extra step of using a photocopier.

The product supports the transmit-once mopying feature when the **Mopier Mode:** setting on the **Device Settings** tab is **Enabled**.

When you use the HP PCL 6 Print Driver, mopying is performed in one of two ways: either through the software or through the product hardware. When **Mopier Mode:** is enabled, mopying takes place through the product hardware. One copy of a multiple-page print job is transmitted once through the network to the product, together with a printer job language (PJL) command directing the product to make the specified number of copies.

When you disable mopying, you are not necessarily disabling multiple collated copies, which the driver can still perform through the software rather than the product hardware (the mopying path that is disabled when you change the **Mopier Mode:** setting to **Disabled**). However, a multiple-copy print job that is sent when the mopier is disabled loses the advantage of transmitting the print job once, because the job is sent through the network for each collated copy.

Mopier mode and collation

Mopying and collating print jobs are independent but closely related functions. Mopying, the ability to send original print jobs to the product, is performed by the print driver. Collating can be controlled by either the print driver or the document software program. The mopying mode is selected by default in the driver and can be disabled by changing the **Mopier Mode:** setting on the **Device Settings** tab to **Disabled**.

Control collation through the print driver by selecting or clearing the **Collated** check box on the **Advanced** tab. Click **Copy Count** under the **Paper Output** setting. You can clear the check box, which is available only when the **Copy Count** option is set to more than 1 copy, to allow the software program to control collation.

To receive uncollated multiple copies of a print job, you must clear the **Collated** check box *and* make sure that the software program collation feature is not selected.

The following table shows the relation between **Mopier Mode:** settings and collation settings in the software program and the driver. The first three columns show the settings; the last column, **Expected result**, shows how a three-page print job would appear.

Table 4-4 Driver Mopier Mode: and collation settings

Mopier Mode	Application collation	Driver collation	Expected result
Disabled	Not selected	Not selected	3 copies uncollated
Disabled	Not selected	Selected	3 copies uncollated
Disabled	Selected	Not selected	3 copies collated

Table 4-4 Driver Mopier Mode: and collation settings (continued)

Mopier Mode	Application collation	Driver collation	Expected result
Disabled	Selected	Selected	3 copies collated
Enabled	Not selected	Not selected	3 copies uncollated
Enabled	Not selected	Selected	3 copies uncollated
Enabled	Selected	Not selected	3 copies collated
Enabled	Selected	Selected	3 copies collated

About tab features

 **NOTE:** The **About** tab is located on the **Properties** tab set. For information about how to gain access to these tabs, see [Properties driver tabs on page 114](#).

The **About** tab provides detailed information about driver component versions. It contains an overall build version number (in parentheses after the model name) together with specific information about each of the components. The information varies according to the product model number, driver, date, and versions. The **About** tab is shown in the following figure.

Figure 4-23 About tab

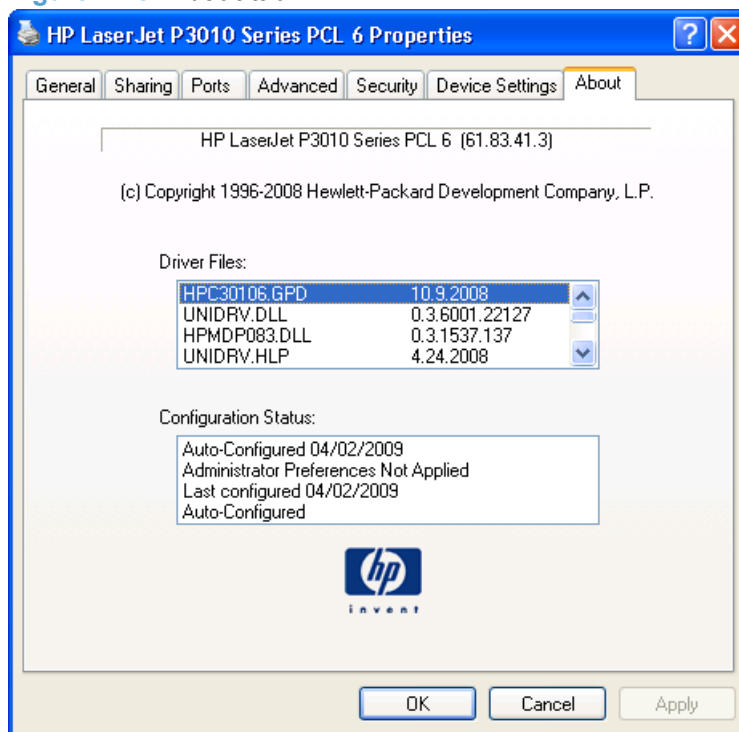

The **About** tab lists driver installation file names and their version numbers. The **About** tab also indicates whether the driver was autoconfigured, whether administrator preferences were set, the date the driver was last configured, and whether the configuration is auto-configured or user-configured.

The **About** button is also available on most driver screens. The **About** button provides a driver version number and creation date.

5 Macintosh software and utilities

- [Supported operating systems for Macintosh](#)
- [Macintosh system requirements](#)
- [Macintosh printing-system software](#)
- [Macintosh install and uninstall instructions](#)
- [HP Printer Utility for Macintosh](#)
- [Use features in the Macintosh printer driver](#)

Supported operating systems for Macintosh

The product supports the following Macintosh operating systems:

- Mac OS X V10.3.9, V10.4, V10.5 and later

 **NOTE:** For Mac OS X V10.4 and later, PPC and Intel Core Processor Macs are supported.

Macintosh system requirements

- PowerPC G3, G4, G5, or Intel Core processor
- 256 MB RAM
- 32 MB of available hard-disk space
- CD-ROM drive or Internet connection

Macintosh printing-system software

The printing-system software for Macintosh is composed of an HP-created postscript (PS) printer definition file (PPD) and a Printer Dialog Extension (PDE) file that work together with the Macintosh OS printing system. These files are used by the Macintosh OS printing system to determine default printer-driver settings and to allow the user to select between the various print options and settings. An HP-supplied Macintosh printer configuration utility is provided, which allows the user to access the HP Embedded Web Server (HP EWS) for additional configuration and product status monitoring. The following are provided on the printing-system CD:

- The HP LaserJet Installer for Macintosh
- Install notes (Readme file)

The following components are installed by the HP LaserJet Installer for Macintosh:

- HP LaserJet P3010 Series PPD
- HP LaserJet P3010 Series PDE
- HP USB EWS Gateway
- HP Printer Utility

HP LaserJet P3010 Series PPD

A postscript printer description (PPD) file is a text file that contains keywords and other information to specify printer features, options, and settings. PPD files are created by printer vendors for a specific postscript printer or printer family. PPD files are created by printer vendors to describe the set of printer features available for their postscript printers. On the Macintosh, PPD files provide all the information necessary to describe a postscript printer's features, including options and default settings. They also contain the postscript code used to invoke those features.

HP LaserJet P3010 Series PDE

A Print Dialog extension file can specify one or more PDEs to load in the Print dialog box to provide HP printer specific features. A printing dialog extension (PDE) is a way to extend the Print dialog box in Mac OS X with custom printer features.

A PPD file and printing dialog extension (PDE) for a printer are bound to a printer queue when the queue is created.

HP USB EWS Gateway

For network connected printers, the EWS can be accessed directly by typing the network IP address or DNS name of the product into the Web browser. HP USB EWS Gateway software, which is automatically installed, allows a Web browser to access the product's EWS if the product is connected using a USB cable. Click the **Utility** button when using a USB connection to access the EWS through the Web browser.

HP Printer Utility

Use the HP Printer Utility to configure, administer, and set up product features that are not available from the printer driver. You can use the HP Printer Utility with HP printers connected via USB, ethernet, and wireless networks.

Supported printer drivers for Macintosh

The HP installer provides Postscript Printer Description (PPD) files, Printer Dialog Extensions (PDEs), and the HP Printer Utility for use with Macintosh computers.

The PPDs, in combination with the Apple postscript printer drivers, provide access to device features. Use the Apple postscript printer driver that comes with the computer.

Priority for print settings for Macintosh

Changes to print settings are prioritized depending on where the changes are made:

 **NOTE:** The names of commands and dialog boxes might vary depending on your software program.

- **Page Setup dialog box:** Click **Page Setup** or a similar command on the **File** menu of the program you are working in to open this dialog box. Settings changed here might override settings changed anywhere else.
- **Print dialog box:** Click **Print**, **Print Setup**, or a similar command on the **File** menu of the program you are working in to open this dialog box. Settings changed in the **Print** dialog box have a lower priority and do *not* override changes made in the **Page Setup** dialog box.
- **Default printer driver settings:** The default printer driver settings determine the settings used in all print jobs, *unless* settings are changed in the **Page Setup**, **Print**, or **Printer Properties** dialog boxes.
- **Printer control-panel settings:** Settings changed at the printer control panel have a lower priority than changes made anywhere else.

Change printer-driver settings for Macintosh

Change the settings for all print jobs until the software program is closed	Change the default settings for all print jobs	Change the product configuration settings
<ol style="list-style-type: none">1. On the File menu, click Print.2. Change the settings that you want on the various menus.	<ol style="list-style-type: none">1. On the File menu, click Print.2. Change the settings that you want on the various menus.3. On the Presets menu, click Save as and type a name for the preset. <p>These settings are saved in the Presets menu. To use the new settings, you must select the saved preset option every time you open a program and print.</p>	<p>NOTE: Configuration settings might not be available in Classic mode.</p> <p>Mac OS X V10.3 or Mac OS X V10.4</p> <ol style="list-style-type: none">1. From the Apple menu, click System Preferences and then Print & Fax.2. Click Printer Setup.3. Click the Installable Options menu. <p>Mac OS X V10.5</p> <ol style="list-style-type: none">1. From the Apple menu, click System Preferences and then Print & Fax.2. Click Options & Supplies.3. Click the Driver menu.4. Select the driver from the list, and configure the installed options.

Software for Macintosh computers

HP Printer Utility

Use the HP Printer Utility to set up product features that are not available in the printer driver.

You can use the HP Printer Utility when the product uses a universal serial bus (USB) cable or is connected to a TCP/IP-based network.

Open the HP Printer Utility

Open the HP Printer Utility in Mac OS X V10.3 and V10.4

1. Open the Finder, click **Applications**, click **Utilities**, and then double-click **Printer Setup Utility**.
2. Select the product that you want to configure, and then click **Utility**.

1. From the **Printer** menu, click **Printer Utility**.

- or -

2. From the **Print Queue**, click the **Utility** icon.

HP Printer Utility features

The HP Printer Utility consists of pages that you open by clicking in the **Configuration Settings** list. The following table describes the tasks that you can perform from these pages.

Table 5-1 HP Printer Utility features

Item	Description
Device Information	Allows you to view and print a configuration page.
Supplies Status	Shows the device supplies status and provides links for online supplies ordering.
File Upload	Transfers files from the computer to the device.
Upload Fonts	Transfers font files from the computer to the device.
HP Support	Provides access to technical assistance, online supplies ordering, online registration, and recycling and return information.
Duplex Mode	Turns on the automatic two-sided printing mode.
Economode & Toner Density	Turns on the Economode setting to conserve toner, or adjusts toner density.
Resolution	Changes the resolution settings, including the REt setting.
Trays Configuration	Changes the default tray settings.
Stored Jobs	Manages print jobs that are stored on the device hard disk.
E-mail Alerts	Configures the device to send e-mail notices for certain events.
Network Settings	Changes the device network settings and provides access to the embedded Web server. Provides the ability to turn on or off Bonjour support or change the device service name that is listed on a network.
Protect Direct Ports	Use this setting to disable printing over USB or parallel ports.
Additional Settings	Provides access to the embedded Web server.
Supplies Management	Allows you to select how the printer responds to low or depleted supplies.

Embedded Web Server

The product is equipped with the HP Embedded Web Server (HP EWS), which provides access to information about device and network activities. For a complete explanation of the features and functionality of the HP EWS, see the *HP LaserJet P3010 Series Printers Embedded Web Server User Guide*, which is available on the printing-system software CD.

Availability

This STR provides information about the availability of the printing-system software and related software and firmware. Printing-system software on a CD is available from HP fulfillment centers.

- [Printing-system software on the Web](#)
- [In-box printing-system software CD](#)

Printing-system software on the Web

All software that is contained on the installation CDs is also available on the Web.

Web deployment is the preferred method for obtaining the latest software. The HP Web site offers an option for automatic e-mail notification about new software releases. See the HP Proactive support link on the Download Drivers and Software page.

 **NOTE:** This STR describes drivers that are shipped on the printing-system software CD that comes with the product. This STR does *not* describe drivers that will become available on the Web.

The printing-system software is available for download at the following Web site:

www.hp.com/support/ljp3010

In-box printing-system software CD

One CD is included in-box with the product. The printing-system software CD contains the following components:

- Software installer
- Administrator software and documentation
- Links to the HP Universal Print Drivers on the Web
- User guides
- Show Me How content
- Product demonstrations and simulations
- Support information

The CD is divided into two partitions, one for each of the following operating systems:

- Windows
- Macintosh

The files in each partition of the printing-system software CD include documentation files and files that are required to install and uninstall the printing-system software components. Use the printing-system software CD to install the printing-system software.

- [Macintosh partition](#)
- [CD versions](#)

Macintosh partition

The HP Macintosh printing-system software files reside in the Macintosh partition. The HP LaserJet Installer for Macintosh is at the root of the Macintosh CD partition. The user manuals (.PDF) are grouped by language and are in the Documentation directory on the Macintosh partition of the software CDs.

CD versions

The printing-system software CD is available in three regional versions and contains the printing-system software in all supported languages as follows:

CD 1 – Americas & Western Europe

- CA = Catalan (Català)
- DA = Danish (Dansk)
- DE = German (Deutsch)
- EN = English

- ES = Spanish (Español)
- ET = Estonian (Eesti)
- FI = Finnish (Suomi)
- FR = French (Français)
- HE = Hebrew
- IT = Italian (Italiano)
- LT = Lithuanian
- LV = Latvian
- NL = Dutch (Nederland)
- NO = Norwegian (Norsk)
- PT = Brazilian Portuguese (Português)
- SV = Swedish (Svenska)

CD 2 – Asia Pacific

- EN = English
- ID = Indonesia (Bahasa)
- JA = Japanese
- KO = Korean
- TH = Thai
- VI = Vietnamese
- ZHCN = Simplified Chinese
- ZHTW = Traditional Chinese

CD 3 – Eastern Europe

- AR = Arabic
- BG = Bulgarian
- CS = Czech (Cesky)
- EL = Greek
- EN = English
- FR = French
- HR = Croatian (Hrvatski)
- HU = Hungarian (Magyar)
- KK = Kazakh

- PL = Polish (Polski)
- RO = Romanian
- RU = Russian (Russ)
- SK = Slovak
- SL = Slovenian
- SR = Serbian
- TR = Turkish (Turkçe)
- UK = Ukranian

The printing-system software CD contains the following documents:

- *HP Jetdirect Administrator's Guide*
HP LaserJet P3010 Series Printers Control Panel Wall Poster
- *HP Driver Preconfiguration Support Guide*
- *HP LaserJet P3010 Series Printers User Guide*

Macintosh install and uninstall instructions

- [Install the Macintosh printing-system software](#)
- [Remove the printing-system software from Macintosh operating systems](#)

Install the Macintosh printing-system software

On a Macintosh computer, the printing-system software installation procedures are the same for a network administrator, a network client, or a single user. Install the printing-system software on any computer that has access rights to the product. The computer user must also have administrative rights on the computer to install the printing-system software.

- [General installation for Macintosh operating systems](#)
- [Detailed Mac OS X installation](#)
- [Setup instructions](#)

General installation for Macintosh operating systems

1. If you are connecting the product to a network, connect the network cable to the network port. If you are connecting the product to a computer by using the USB cable, install the software *before* connecting the USB cable.
2. Insert the printing-system software CD into the CD-ROM drive.

 **NOTE:** If the **HP LaserJet** installer browser screen does not open automatically when the CD is inserted into the CD-ROM drive, double-click the product CD image on the desktop to open the installer browser screen.

3. Double-click the product .MKPG icon to start the printing-system software installation.

 **NOTE:** In the HP LaserJet installer browser screen, double-click the **Documentation** icon to gain access to the manuals. Select a language folder and locate the available guides which are in .PDF format. The user guide is a .PDF file that is named like: P3015_use_enww.pdf.

4. The **Introduction** dialog box appears. Click **Continue** and then follow the onscreen instructions to complete the printing-system software installation.

 **NOTE:** When the printing-system software is installing, be patient. The installer must perform an initial search of the computer, which can take up to 1 minute. During this time, the installer might appear to be stalled.

5. When the printing-system software installation is complete, click **Close**.
6. Continue with the steps for setting up a product.

The software program that you use to finish setting up the product varies by operating system. The following table shows the product setup tools that are available.

Table 5-2 Adding a product in Macintosh operating systems

Operating system	Print Center	Printer Setup Utility	Print & Fax
Mac OS X V10.3		x	x

Table 5-2 Adding a product in Macintosh operating systems (continued)

Operating system	Print Center	Printer Setup Utility	Print & Fax
Mac OS X V10.4		x	x
Mac OS X V10.5 and later		x	x

Detailed Mac OS X installation

This section provides information about the Macintosh printing-system software installation dialog-box sequence for the **Easy Install** type, which is the typical type of printing-system software installation.

 **NOTE:** If you are connecting the product to a network, connect the network cable to the network port. If you are connecting the product to a computer by using the USB cable, install the software *before* connecting the USB cable.

Insert the printing-system software CD into the CD-ROM drive.

If the **HP LaserJet** installer browser screen does not open automatically when the CD is inserted into the CD-ROM drive, double-click the product CD image on the desktop to open the installer browser screen.

Figure 5-1 Product CD image



The **HP LaserJet** installer browser screen appears.

Figure 5-2 HP LaserJet installer browser screen

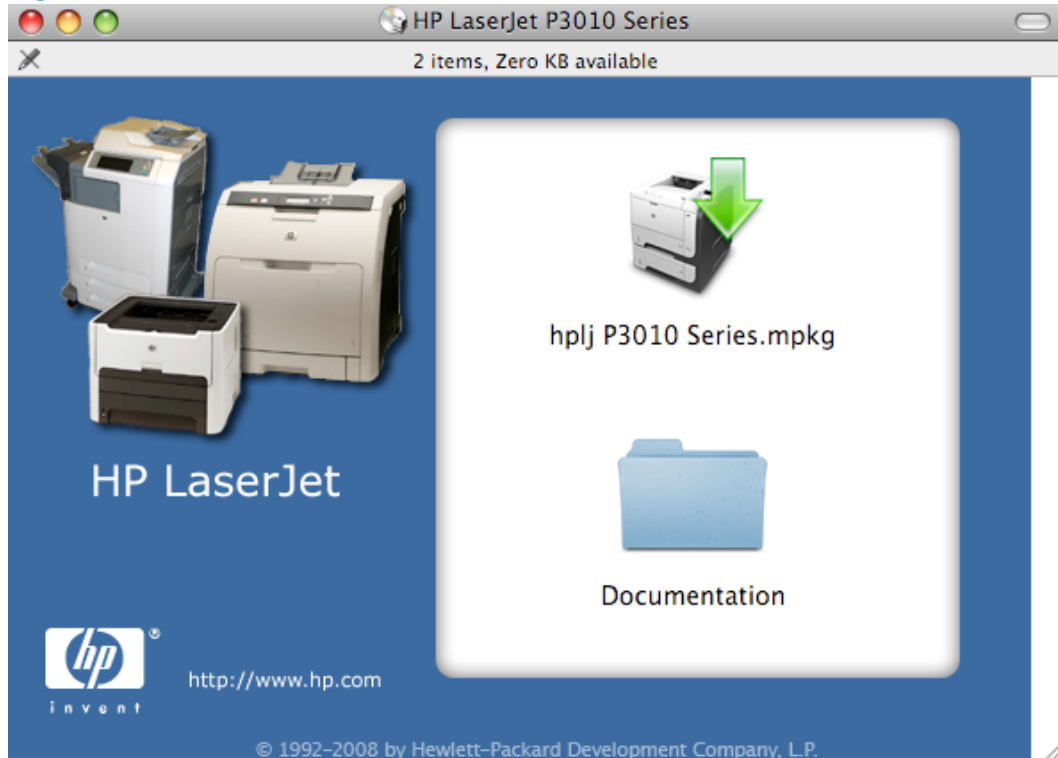

In the **HP LaserJet** installer browser screen, double-click the product .MKPG icon. This begins the printing-system installation.

 **NOTE:** The file name displayed on your **HP LaserJet** installer browser screen may be different than the file name displayed in the above figure.

NOTE: In the HP LaserJet installer browser screen, double-click the **Documentation** icon to gain access to the product manuals. Select a language folder and locate the available guides which are in .PDF format. The user guide is a .PDF file that is named like: P3015_use_enww.pdf.

Figure 5-3 Introduction dialog box



Click **Continue**. The **Software License Agreement** dialog box appears.

Figure 5-4 Software License Agreement dialog box

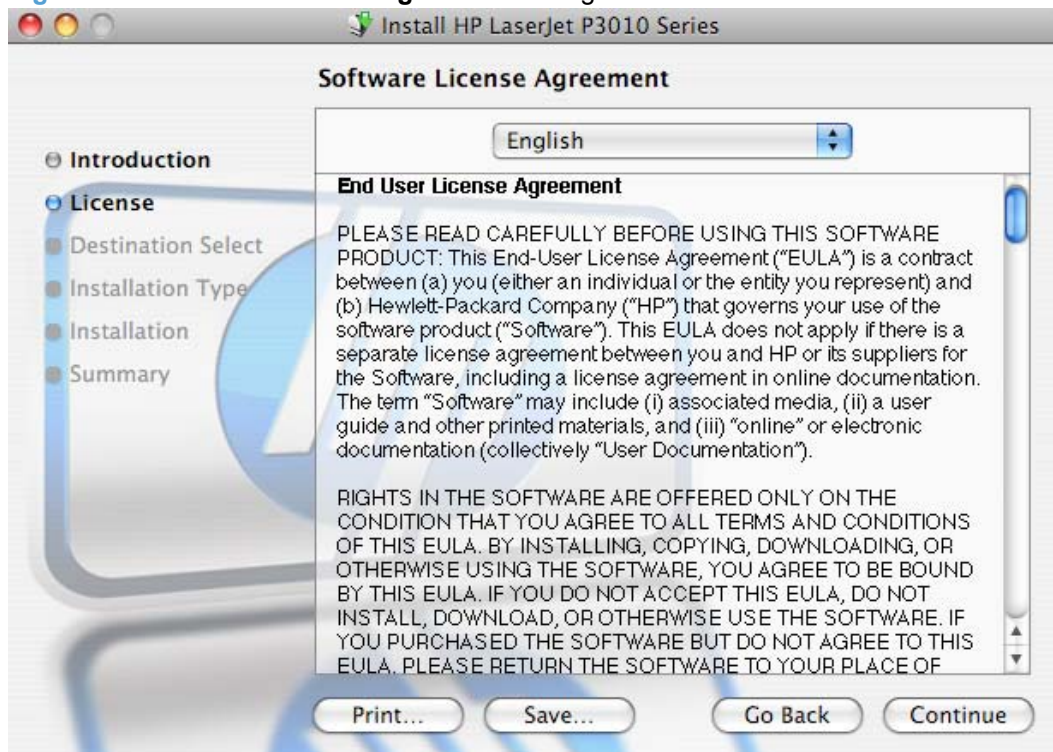

Click **Print...** to open the **Page Setup** dialog box and print a copy of the License Agreement.

Click **Save** to open the system **Save** dialog box and save the License Agreement to disk.

Click **Go Back** to return to the previous screen.

Read the Software License Agreement and then click **Continue**. The **Agree/Disagree** dialog box appears.

Figure 5-5 Agree/Disagree dialog box

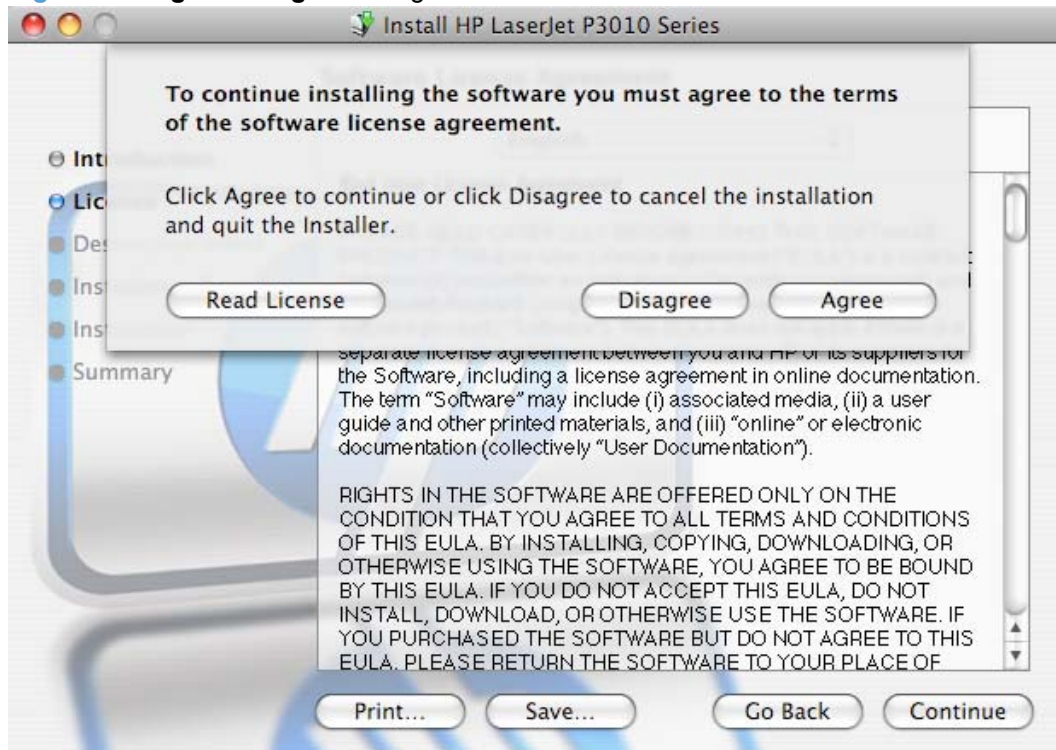

Click **Disagree** to end the installation and close the installer.

Click **Agree** to continue the installation. The **Select a Destination** dialog box appears.

Figure 5-6 Select a Destination dialog box

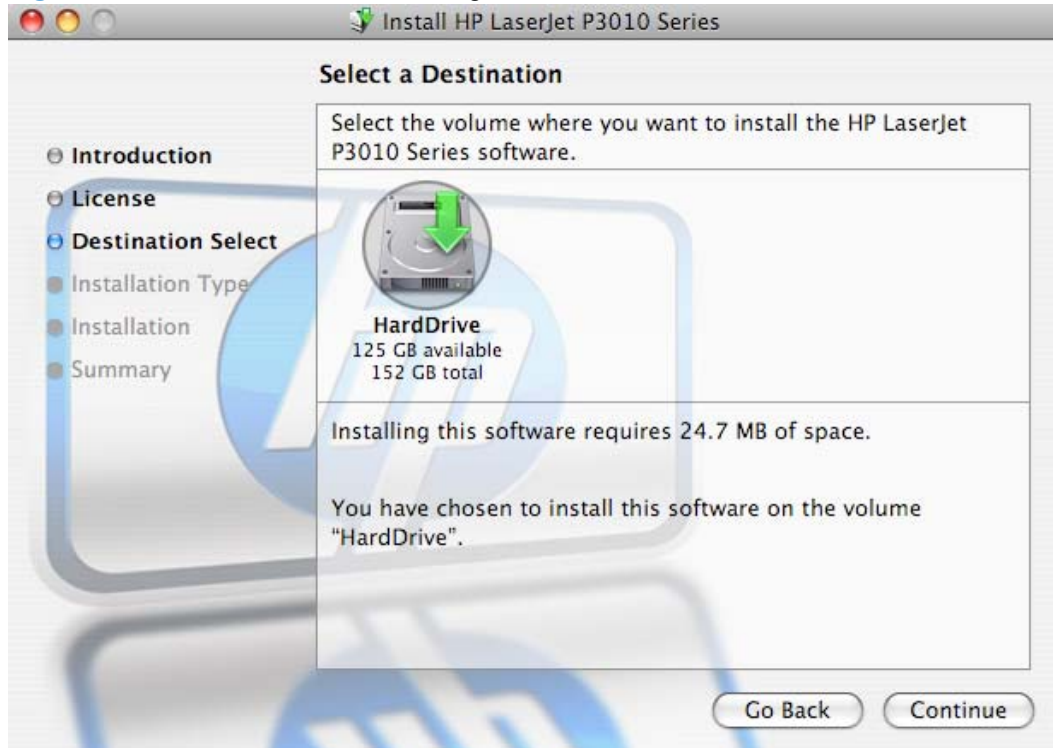

Click **Go Back** to go back to the previous screen.

Click **Continue** to continue the installation. The **Installation Type** dialog box appears.

Figure 5-7 Installation Type dialog box

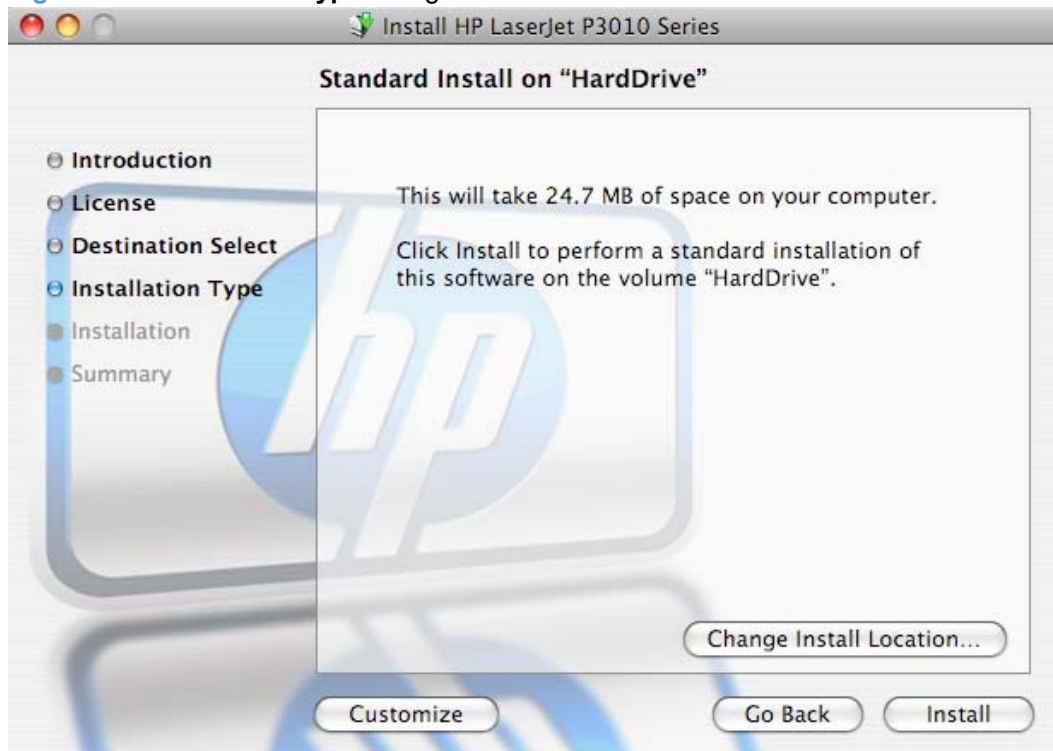

The default installation method when installing the software on a workstation that does not have a previous version of the software installed is **Standard Install on “HardDrive”**.

If you have a previous version of the software installed on a workstation this installation screen may indicate that update to the software is being performed.

Click **Install** to start the installation on the selected disk.

You can also click **Customize** to go to the **Custom Install** dialog box.

Click **Go Back** to go back to the previous dialog box.

Figure 5-8 Custom Install dialog box

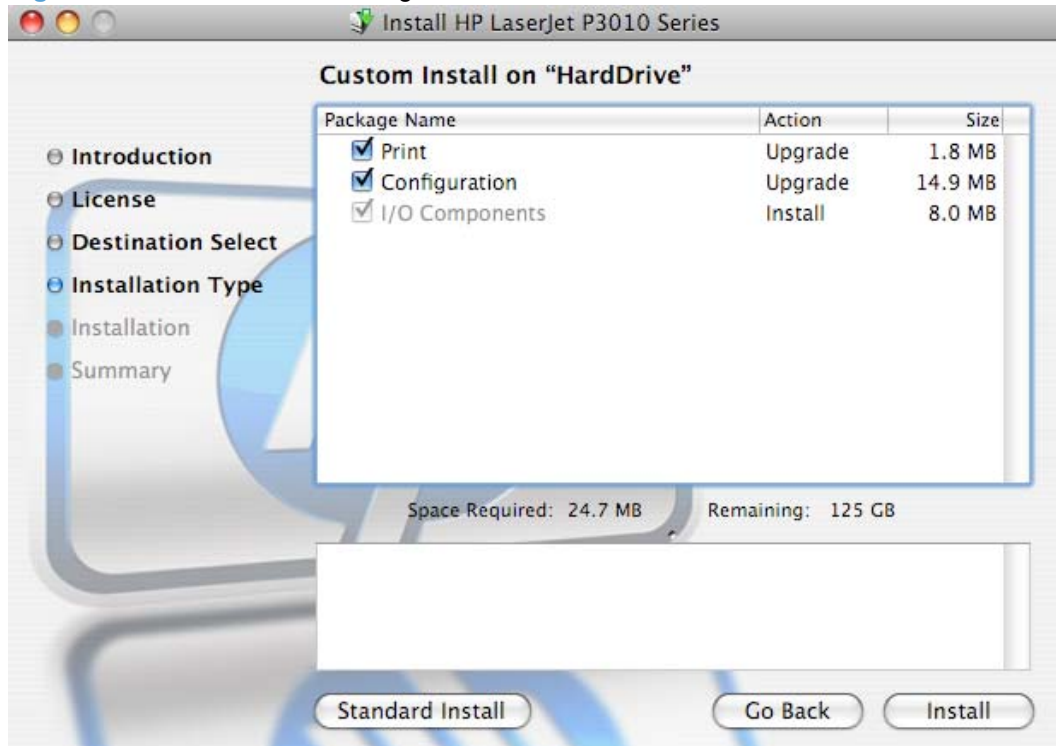

Use the check boxes in the **Package Name** list to select the printing-system components to install.

Click **Easy Install** to start the installation on the selected disk.

NOTE: If the printing-system software has been installed previously on the computer, the Action column for the component list and the button to start the installation on the selected disk changes to **Upgrade**.

Click **Go Back** to go back to the previous dialog box.

The **Authenticate** dialog box appears.

Figure 5-9 Authenticate dialog box



Type the correct administrator name and password, and then click **OK** to continue. The **Installing** dialog box appears.

Click **Cancel** to exit the installation.

Figure 5-10 Installing dialog box



The **Installing** dialog box shows installation progress. No action is required.

When the installation is complete, the **Install Succeeded** dialog box appears.

Figure 5-11 Install Succeeded dialog box

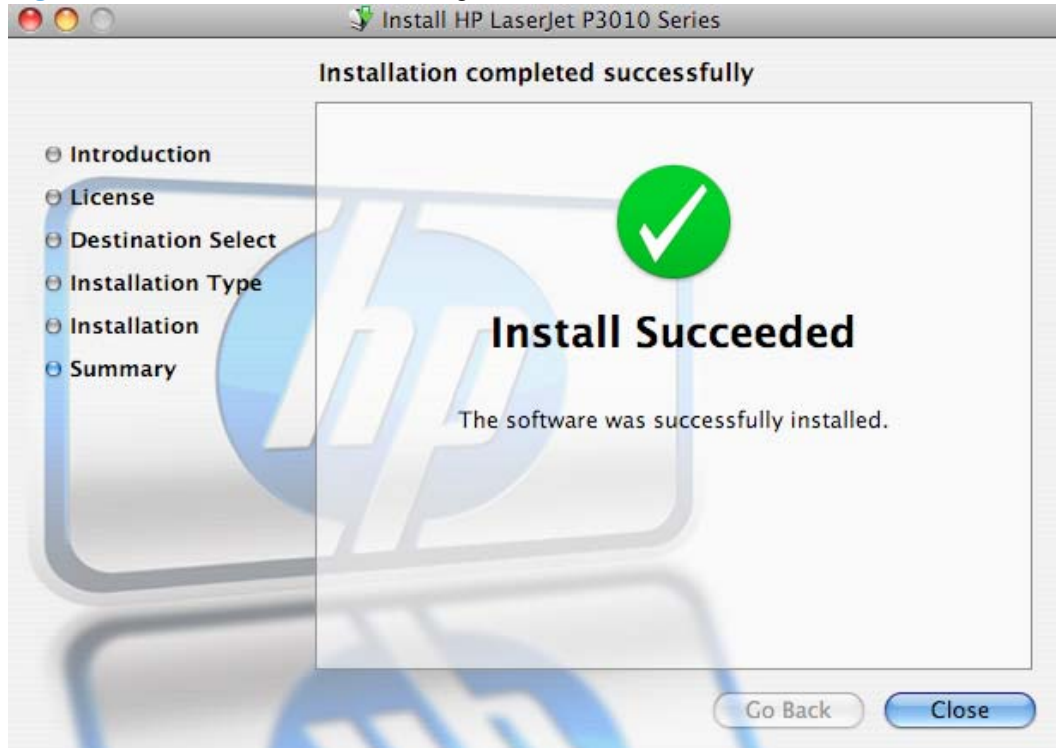

Click **Close** to exit the installer.

 **NOTE:** After installing the printing-system software, the product must be set up.

Setup instructions

This section contains information about the following topics:

- [Setting up a printer with Mac OS X v10.4, v10.5, and later](#)
- [Setting up a printer with Mac OS X v10.3.9](#)
- [Troubleshooting the product setup](#)

Setting up a printer with Mac OS X v10.4, v10.5, and later

Complete these steps *after* completing the printing-system software installation.

1. If you are installing the product using a USB connection, connect the USB cable between the product and the computer. Turn on the product. If you are installing using a network connection, verify that the network cable is connected to the product and that the product is on.
2. In the **Applications** folder (in the **Finder** utility), open the **Utilities** folder, and then run the **Printer Setup Utility**.
3. If you are installing the product using a USB connection, verify that the product appears in the printer list. The **Name** column in the printer list should display the product name. If this is the case, the USB setup is complete.

If the product does not appear, or if the correct information does not appear in the field, see [Troubleshooting the product setup on page 185](#).

If you are installing the product using a network connection, continue with the following steps.

4. Click **Add** in the **Printer List** to open the **Printer Browser** screen.
5. You can use either Bonjour (default browser) or IP Printing for the network connection.

 **NOTE:** Bonjour is the easiest method and is the best method to use if the product is installed on your local network.

IP Printing *must* be used if you are installing the product on a different network.

If you are using Bonjour, carry out the following steps:

- a. Click the **Default Browser** tab.
- b. Select the product from the list. The software verifies that the product is connected to the network and the **Print Using** field is automatically populated with the correct PPD for the product.

 **NOTE:** If you are on a network that has more than one product, print a configuration page and match the Bonjour Printer Name to the name on the list to identify the product that you are installing.

NOTE: If the product does not appear in the list, verify that the product is on and connected to the network, then try turning the product off and then on again. If the product PPD does not appear in the **Print Using** pull-down list, turn the computer off and then on again, then restart the setup process. For more troubleshooting information, see [Troubleshooting the product setup on page 185](#).

- c. Click the **Add** button.
- d. Verify or select the appropriate **Installable Options**, and then click **Continue**. Select **Make Default** to set the device as your default.

You are finished with the setup process.

If you are using the IP Printing method, carry out the following steps:

- a. Click the **IP Printer** tab.
- b. Choose **HP Jet Direct – Socket** from the **Protocol** pull-down menu. This is the recommended setting for HP products.
- c. Follow these steps to print the configuration pages.

Print a configuration page

- i. Press the **menu** button  to open the menus.
- ii. Press the **up arrow** ▲ or the **down arrow** ▼ to scroll to **INFORMATION**, and then press **OK**.
- iii. Press the **up arrow** ▲ or the **down arrow** ▼ to scroll to **PRINT CONFIGURATION**.
- iv. Press **OK** to print the configuration page.

- d. On the first configuration page, under **IPv4**, find the IP Address. Type this address into the **Address** field on the add printer screen.
 - e. The **Name**, **Location**, and **Print Using** information will automatically be filled in. If the product PPD does not appear in the **Print Using** field, turn the computer off and then on again and restart the setup process.
6. Select the product and click **Add**. The **Installable Options** screen appears.
 7. In the **Optional Trays:** drop-down menu, select the trays that are installed on the product.
 8. In the **Collation in Printer:** drop-down menu, select the amount of memory and hard disk combination that is installed in the product:
 9. If the product has a hard disk, select **Installed** from the **Printer Hard Disk** drop-down menu.
 10. If the product has a duplex unit, select the **Duplex Unit** check box.
 11. In the **Accessory Output Bins:** drop-down menu, select the output bins that are installed on the product.
 12. In the **Paper Matching:** drop-down menu, select one of the following options:
 - **Prompt User for correct size**
 - **Nearest Size & Scale**
 - **Nearest Size & Crop**
 13. After you have selected the settings in the **Installable Options** screen, click **Continue**. The product name appears in the **Printer List** and the setup is complete.

Setting up a printer with Mac OS X v10.3.9

Complete these steps *after* completing the printing-system software installation.

1. If you are installing the product using a USB connection, connect the USB cable between the product and the computer. Turn on the product. If you are installing using a network connection, verify that the network cable is connected to the product and that the product is on.
2. In the **Applications** folder, open the **Utilities** folder, and then run the **Printer Setup Utility**.
3. If you are installing the product using a USB connection, verify that the product appears in the printer list. The **Kind** column in the printer list same change as before should display the product name. If this is the case, the setup is complete.

If the product does not appear, or if the correct information does not appear in the **Kind** field, see [Troubleshooting the product setup on page 185](#).

If you are installing the product using a network connection, continue with the following steps.

4. Click **Add** and then click **Add** to open the add printer screen.
5. Select the network connection protocol in the top pull-down menu. The two supported protocols are **Rendezvous** and **IP Printing**.

 **NOTE:** Rendezvous is the easiest method and is the best method to use if the product is installed on your local network.

IP Printing *must* be used if you are installing the product on a different network.

If you are using Rendezvous, carry out the following step:

Select the product in the **Name** list. The **Printer Model** and **Model Name** are selected automatically.

 **NOTE:** If you are on a network that has more than one product, print a configuration page and match the Rendezvous Printer Name to the name on the list to identify the product that you are installing.

 **NOTE:** If the product does not appear in the list, verify that the product is on and connected to the network. If it still does not appear, try turning the product off and then on again. Finally, turn the computer off and then on again, then restart the setup process. For more troubleshooting information, see [Troubleshooting the product setup on page 185](#).

 **NOTE:** If the automatic selection fails, or if you want to manually select a .PPD file, click the **Printer Model** pull-down menu, select **HP**, and then select the .PPD file that you want to add. If the product PPD does not appear in the **Model Name** list, turn the computer off and then on again and restart the setup process.

If you are using IP Printing, carry out the following steps:

- a. Choose **Socket/HP Jet Direct** from the **Printer Type** pull-down menu. This is the recommended setting for HP products.
- b. Follow these directions to print the product configuration pages.

Print a configuration page

- i. Press the **menu** button  to open the menus.
 - ii. Press the **up arrow** ▲ or the **down arrow** ▼ to scroll to **INFORMATION**, and then press **OK**.
 - iii. Press the **up arrow** ▲ or the **down arrow** ▼ to scroll to **PRINT CONFIGURATION**.
 - iv. Press **OK** to print the configuration page.
- c. On the first configuration page, under **Product Settings**, find the IP Address. Type this address into the **Printer Address** field on the add printer screen.
 - d. Select the **Printer Model** and select the product in the **Model Name** list. If the product PPD does not appear in the **Model Name** list, turn the computer off and then on again and restart the setup process.
6. Click **Add**. The product appears in the **Printer List**.
 7. To configure installable options such as a duplexing unit or optional paper trays, click **Show Info?** and select **Installable Options** in the drop-down menu.

 **NOTE:** This step is necessary only for network connections and USB connections that use Rendezvous/Bonjour. AppleTalk automatically configures the installable options.

8. In the **Optional Trays:** drop-down menu, select the trays that are installed on the product.
9. In the **Collation in Printer:** drop-down menu, select the amount of memory and hard disk combination that is installed in the product:
10. If the product has a hard disk, select **Installed** from the **Printer Hard Disk** drop-down menu.

11. If the product has a duplex unit, select the **Duplex Unit** check box.
12. In the **Paper Matching**: drop-down menu, select one of the following options:
 - **Prompt User for correct size**
 - **Nearest Size & Scale**
 - **Nearest Size & Crop**
13. Click **Apply Changes**, and then close the **Printer List** dialog box.

Troubleshooting the product setup

If the product does not appear in the printer list after an installation:

Complete each one of these solutions in the order given, and restart the setup process after each one to see if the issue has been resolved.

- Verify that the USB or network cable is connected between the product and the computer and that the product is powered on.
- Try disconnecting and reconnecting the cable. If the computer has more than one USB port, try a different USB port.
- Turn the product off and then back on.
- Turn the computer off and then back on.
- If you are using a USB hub on the computer, disconnect any other USB devices from the hub.

If the wrong PPD appears in the Kind column in the printer list after installation:

1. Unplug the USB cable.
2. Delete the print queue with the incorrect type (for example, Generic PostScript Printer).
3. Reinstall the printing-system software.
4. Turn the computer off and then on.
5. Reconnect the USB cable from the computer to the product.

If these steps do not resolve the problem, delete the incorrect print queue, click **Add**, choose the product from the list, and then browse manually for the product PPD.

Remove the printing-system software from Macintosh operating systems

1. Browse to the folder containing the PPDs. In Mac OS X V10.2.8 or later, the PPDs are installed in **Library/Printers/PPDs/Contents/Resources:<lang>.lproj**, where **<lang>** is the appropriate language.
2. Choose the product .GZ file and drag it to **Trash**.
3. Empty the **Trash**.

HP Printer Utility for Macintosh

The HP Printer Utility is a software program that gives you access to the product in Mac OS X.

The HP Printer Utility does not work when it is installed by using the AppleTalk protocol. Use IP, Bonjour or Rendezvous to enable the HP Printer Utility.

The following topics are discussed:

- [Access to the HP Printer Utility](#)
- [Supplies Status](#)
- [Device Information](#)
- [File Upload](#)
- [Upload Fonts](#)
- [HP Support](#)
- [Duplex mode](#)
- [Economode & Toner Density](#)
- [Resolution](#)
- [Trays Configuration](#)
- [Stored Jobs](#)
- [E-mail Alerts](#)
- [Network Settings](#)
- [Protect Direct Ports](#)
- [Additional Settings](#)
- [Supplies Management](#)

Access to the HP Printer Utility

In Mac OS X v10.3.9, follow these steps to gain access to the HP Printer Utility:

1. Open the Finder.
2. Find and double-click **Printers**. The **Select Printer** screen appears.

In Mac OS X v10.4, v10.5, and later, follow these steps to gain access to the HP Printer Utility:

1. In the **Finder**, click **Applications** and then click **Utilities**.
2. Click to select the **HP Printer Utility**. Click to select the product, and then click **Select**.

The following sections describe the screens and features that are available in the HP Printer Utility.

Supplies Status

The HP Printer Utility opens to the **Supplies Status** screen.

Figure 5-12 Supplies Status screen

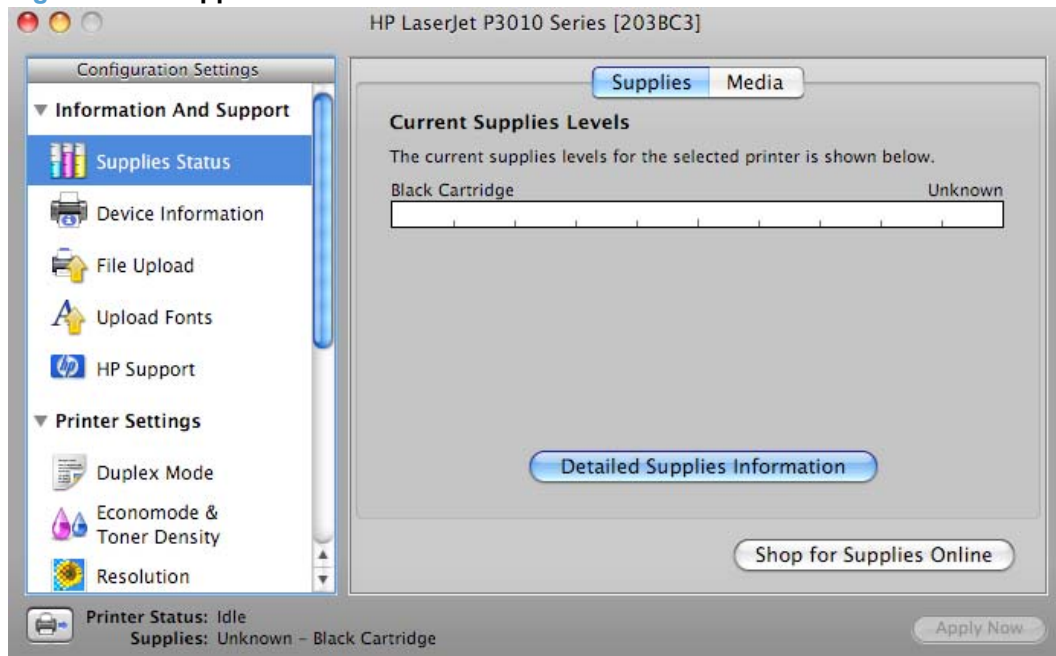

Click **Detailed Supplies Information...** to open the **Supplies Information** screen.

Use the scroll button to see information about the print cartridges.

If you have Internet access and click **Shop for Supplies**, a screen appears that explains the ordering process and describes the kind of information that can be sent about your product to facilitate the ordering of supplies.

Click the **Hewlett-Packard Online Privacy Statement** link to open a screen that shows the HP privacy statement.

You can continue ordering supplies without sending product information by clicking the **continue without sending this information** link.

To send a message to HP, click the **contact HP** link.

On the **Supplies Status** screen, click **Media** to see the status of the trays.

You can also order supplies from this screen by clicking **Order HP Supplies**.

Device Information

Click **Device Information** in the menu on the left to find the product service ID (if assigned), the firmware version, and the serial number.

Figure 5-13 Device Information screen

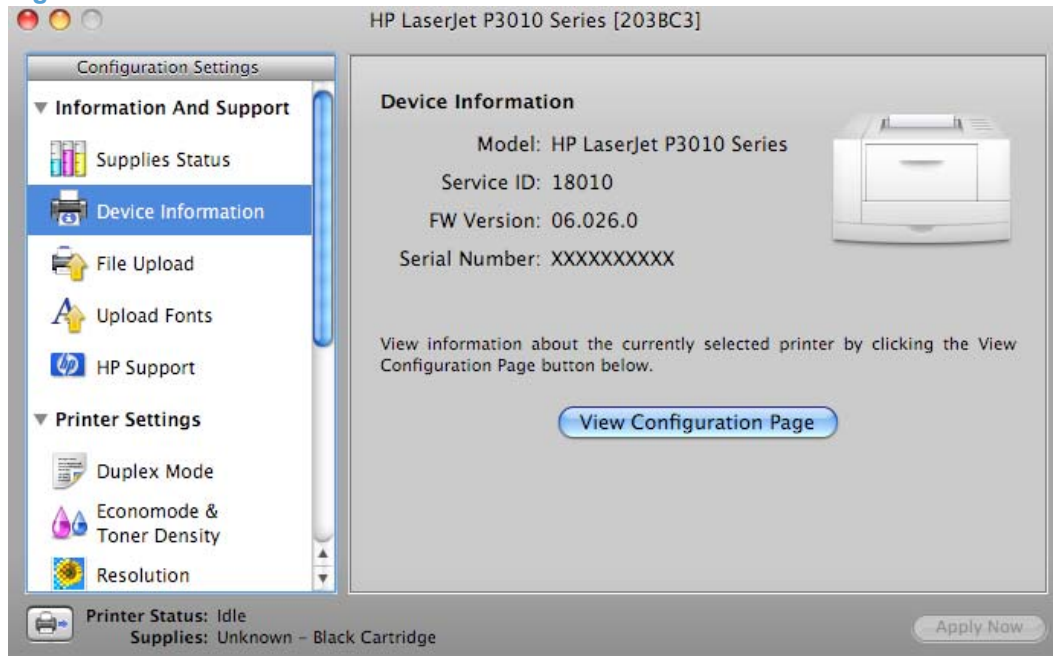

The product configuration page shows other settings; click **View Configuration Page**.

File Upload

Click **File Upload** in the menu on the left to open the **File Upload** screen.

Figure 5-14 File Upload screen

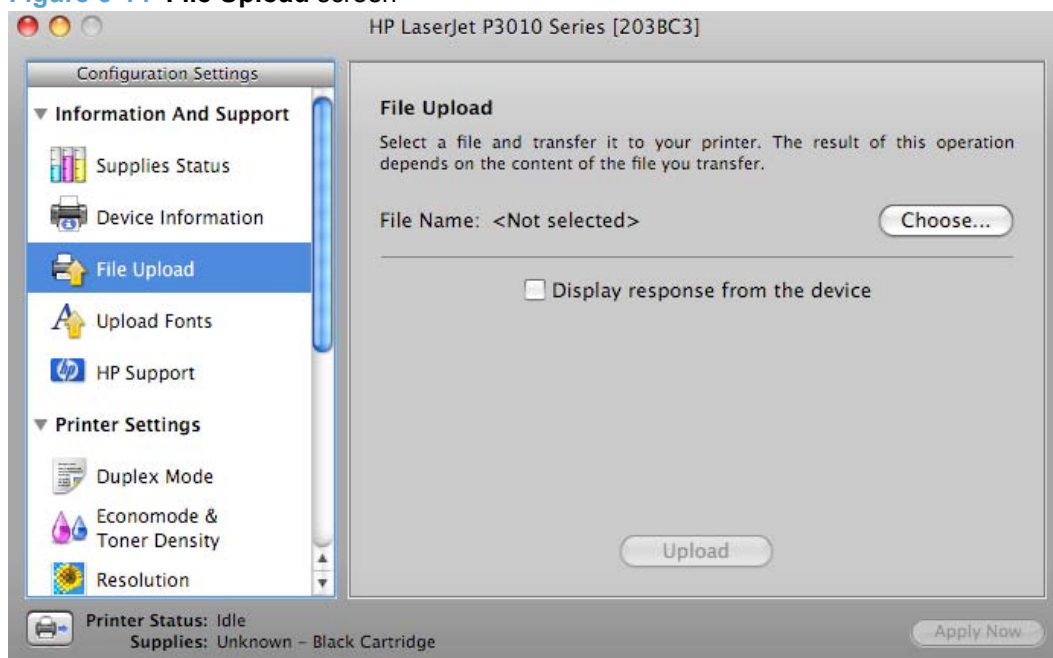

The **File Upload** command is supported for file types that can be sent directly to the product without first being opened through a software program. Some files can be uploaded to the product, but some cannot.

Documents in the following file formats can be printed by using a command line. That is, they do not need to be opened in a software program that supports the file format (such as the Adobe Acrobat or Acrobat Reader programs for .PDF files), but can be sent directly to the product by using the **File Upload** command.

- HP LaserJet printer command language (.PRN)
- Portable document format (.PDF)
- Postscript (.PS)
- Text (.TXT)

On the **File Upload** screen, click **Choose...** to open a navigation screen. Locate the file you want to upload and click **Open**.

On the **File Upload** screen, click **Display response from the device** to see whether the upload was successful. If the file loads successfully, no message appears.

On the navigation screen, select the file and click **Open**. The file name appears in the **File Upload** screen of the HP Printer Utility. Click **Upload**.

Remote firmware update by using the HP Printer Utility

Make sure that you have the tools and files that are necessary for the update. You will need the HP Printer Utility and the P3010FW.RFU file, which is the firmware file for the product. The HP Printer Utility is a software program that is available only for Mac OS X v10.2 and later.

The HP Printer Utility can be found on the HP LaserJet P3010 Series printing-system software CD-ROM that came with the product. If you do not have the CD-ROM, you can obtain the HP Printer Utility by downloading the latest product installer from www.hp.com/go/cljcp3525_software.

The firmware file (P3010FW.RFU) can be downloaded from the following Web site:

www.hp.com/go/cljcp3525_firmware

See [Downloading the new firmware to the product on page 206](#) for more information.

After you have the firmware file and the HP Printer Utility, you are ready to begin the update process. Complete the following steps:

1. Open the HP Printer Utility.
2. Select **File Upload**, click **Choose**, browse to firmware upgrade file, and then click **Open**.
3. On the **Update Firmware** screen, click **Update**.

 **NOTE:** You might receive an error message on the screen indicating that the product is offline. Verify that the product is turned on. If it is, ignore the message. The **Updating** screen appears and the update proceeds as expected.

4. The update process can take several minutes. Let the process finish without further interaction with the product or the computer. The messages described in the section [Printer messages during the firmware update on page 207](#) appear on the control panel.

 **NOTE:** The product automatically turns off and then on again to activate the update; this can happen more than once. At the end of the update process, the **READY** message appears on the control panel. Do *not* turn off the product or interfere with the update until you see this message.

5. Print a configuration page and verify that the firmware revision number matches the revision of the current update.

Upload Fonts

Click **Upload Fonts** in the menu on the left to gain access to fonts that you can upload to the HP LaserJet P3010 Series product.

Figure 5-15 Upload Fonts screen

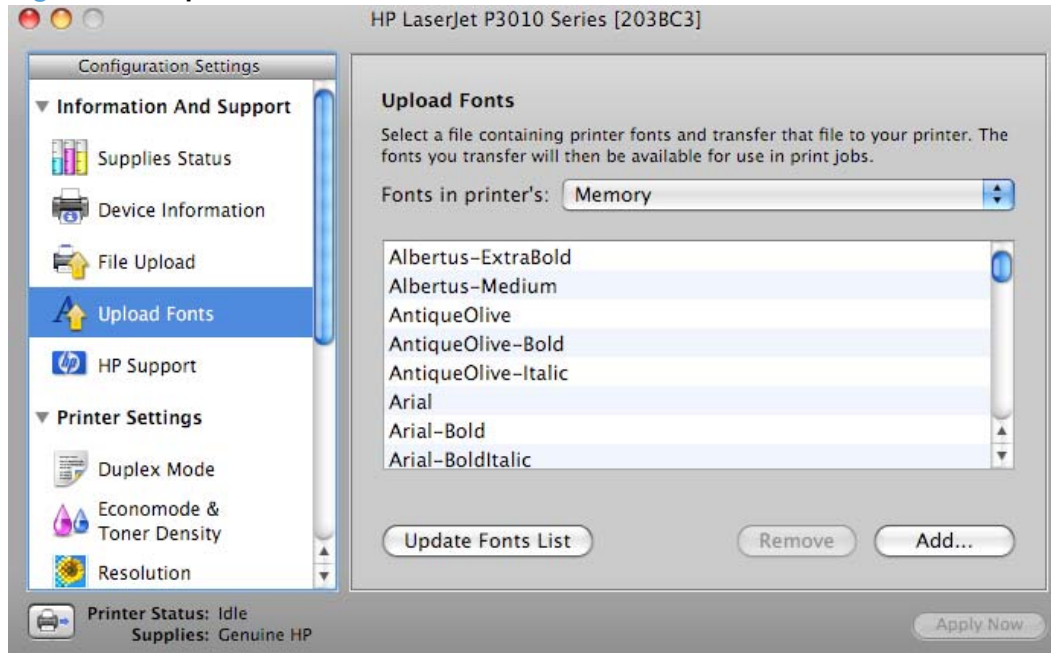

The drop-down menu in the **Upload Fonts** pane has the following options:

- **Memory.** Fonts that are available in the printer memory are listed.
- **Disk.** Select this option to show any fonts that are installed on the printer hard disk or flash disk. By default, no fonts are stored on either of these disks. To upload fonts, select the font name, and then click **Add**.

HP Support

Click **HP Support** to open the **HP Online Support** screen.

Figure 5-16 HP Online Support screen

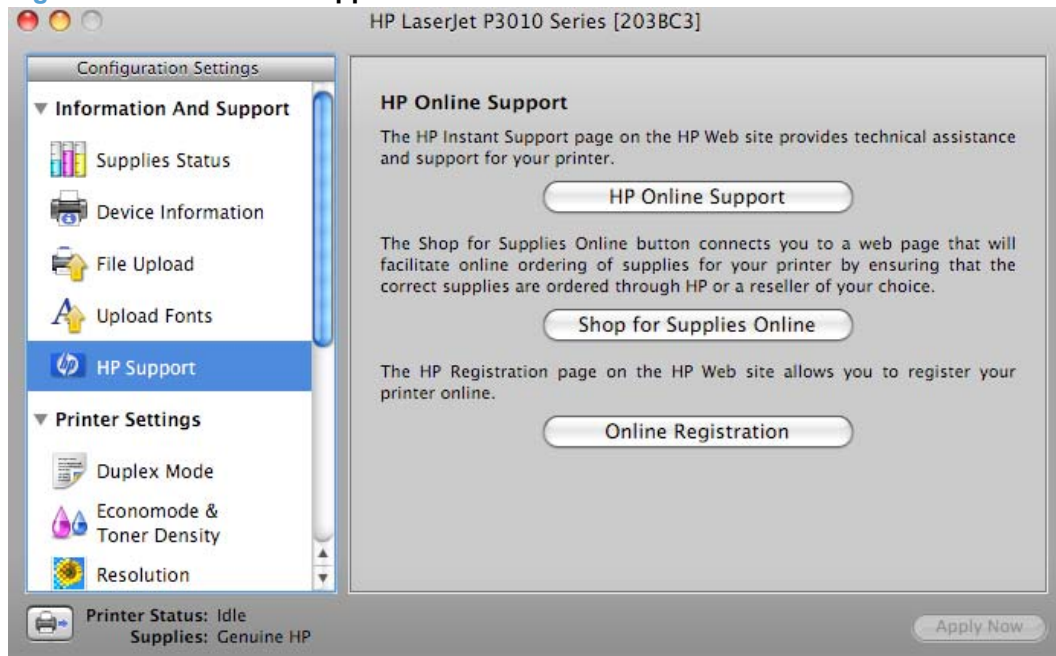

If you have Internet access, you can connect to HP support pages over the Web from this screen.

Click the **HP Online Support** screen to open the HP Instant Support Web page.

1. Click the **Hewlett-Packard Online Privacy Statement** link to open a screen that shows the HP privacy statement.
2. Click the **Product Support** link if you do not want to send information to HP but would like to receive generic product support.
3. Click **Continue** to open a page where you can select the product and find further information about product support.
4. Click **Cancel** to return to the **HP Online Support** screen in the HP Printer Utility.

On the **HP Online Support** screen, click **Shop for Supplies Online** to open the Order Supplies Web page.

The **Online Registration** link is provided to register your product online.

Duplex mode

For the HP LaserJet P3015n, the HP LaserJet P3015dn, and the HP LaserJet P3015x product models, the **Configuration Settings** menu includes a **Duplex Mode** setting. Click this setting to open the **Duplex Mode** screen.

Figure 5-17 Duplex Mode

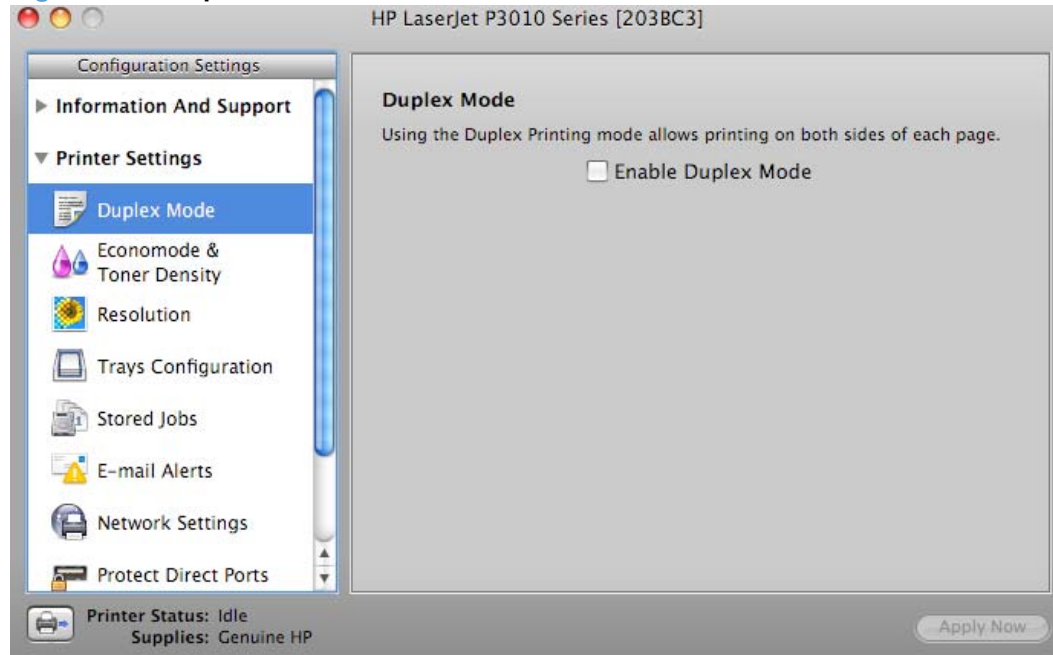

Use the Enable Duplex Mode command to print internal diagnostic and test pages on both sides of the page.

1. Select **Duplex Mode** to open the **Duplex Mode** screen.
2. Select the **Enable Duplex Mode** check box. This box is clear by default.
3. Click **Apply Now** to enable printing on both sides of the page.

Economode & Toner Density

Click **Economode & Toner Density** to open the **Economode & Toner Density** screen.

Figure 5-18 Economode & Toner Density screen

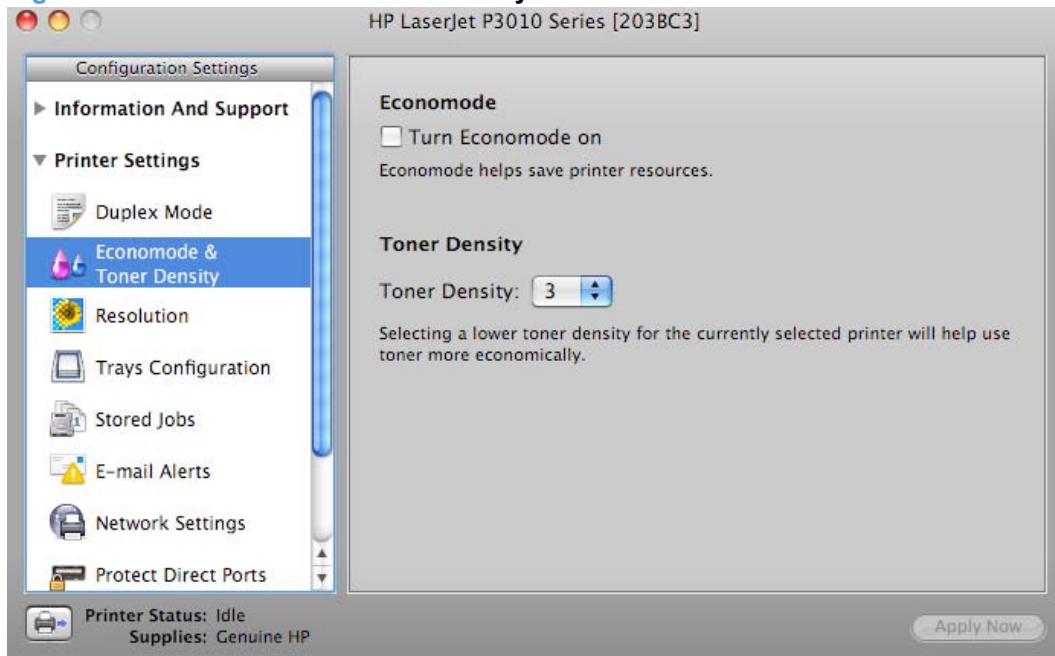

Select the **Turn Economode On** check box to enable this setting. Economode helps save printer resources.

Use the **Toner Density** option to set the toner density for the product. Selecting a lower toner density will help use toner more economically.

Resolution

Click **Resolution** to open the **Resolution** screen.

Figure 5-19 Resolution screen

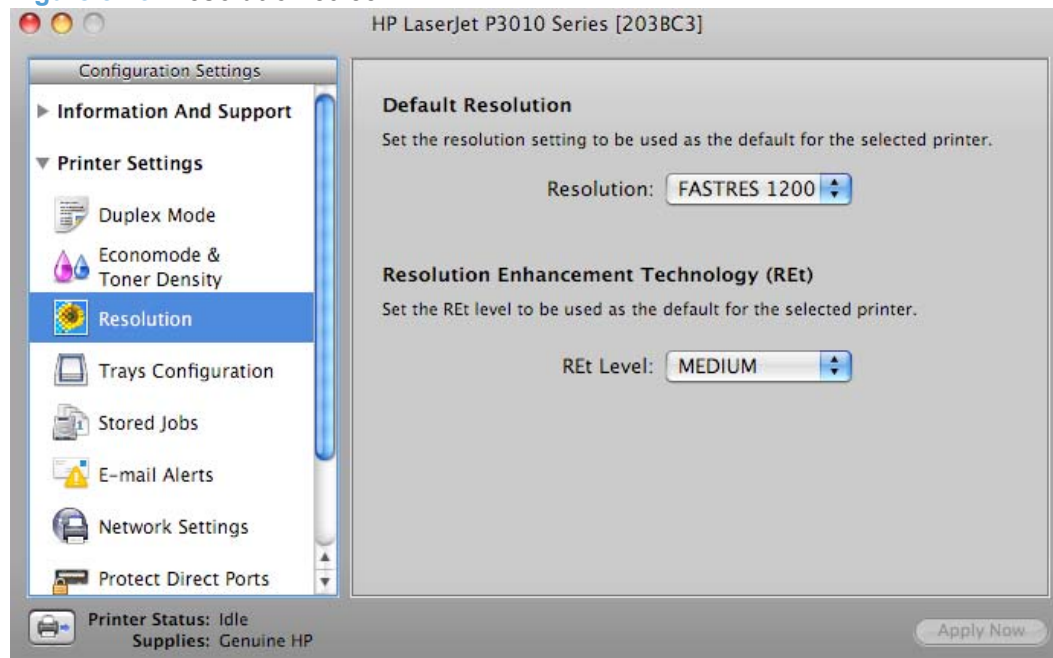

Select the resolution you want to use from the **Resolution** menu. The following resolution options are available for the HP LaserJet P3010 Series printers.

- **FastRes 1200.** Prints using 1200 x 600 resolution, is faster than full 1200 x 1200 resolution, but has slightly lower print quality.
- **ProRes 1200.** Prints using 1200 x 1200 resolution, prints slower than the other resolutions, but has the best print quality.
- **600 dpi.** Prints using standard 600 dpi resolution.

Select the REt level you want to use from the **REt Level** menu.

Trays Configuration

The **Trays Configuration** screen is shown in the following figure.

Figure 5-20 Trays Configuration screen

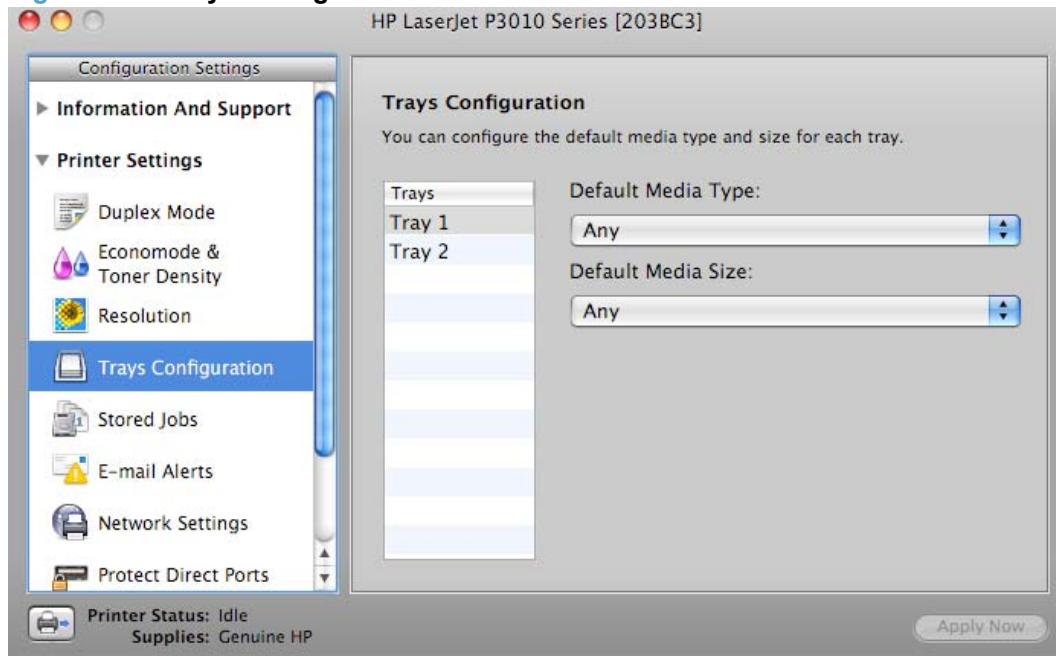

1. Select **Trays Configuration** to change paper size and type for each of the trays installed on your product.
2. To change the paper type, select a tray and then select a different paper type in the **Default Media Type** drop-down menu.
3. To change the paper size, select a tray and then select a different paper size in the **Default Media Size** drop-down menu.
4. Click **Apply Now** to save the settings.

Stored Jobs

Select **Stored Job** to change the **Enable Job Storing** setting. This setting is selected by default. Click to clear the check box to disable the job-storing feature.

Figure 5-21 Enable Job Storing screen

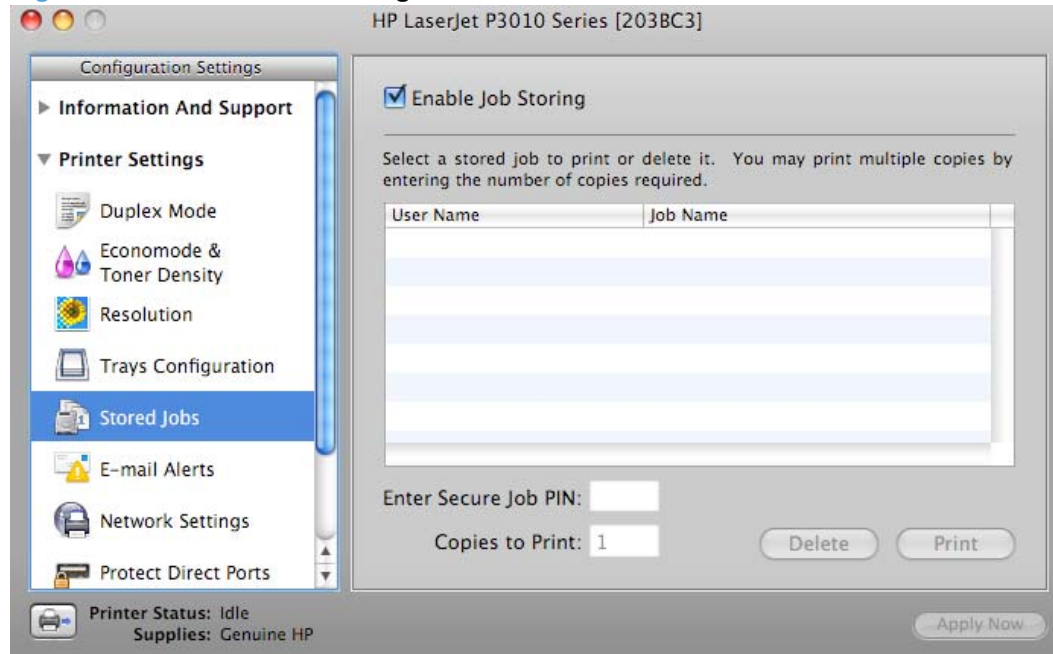

You can type a PIN for your job in the **Enter Secure Job PIN** field.

Select the number of copies in the **Copies to Print** field.

Select a stored job and click **Print** to print the job.

Select a stored job and click **Delete** to delete the job.

E-mail Alerts

Select **E-mail Alerts** to configure the HP LaserJet P3010 Series product to send e-mail notifications to users.

If a user name and password have been set, you might need to obtain them from the IT administrator. For more information, see the *HP LaserJet P3010 Series Embedded Web Server User Guide*.

Figure 5-22 E-mail Alerts screen

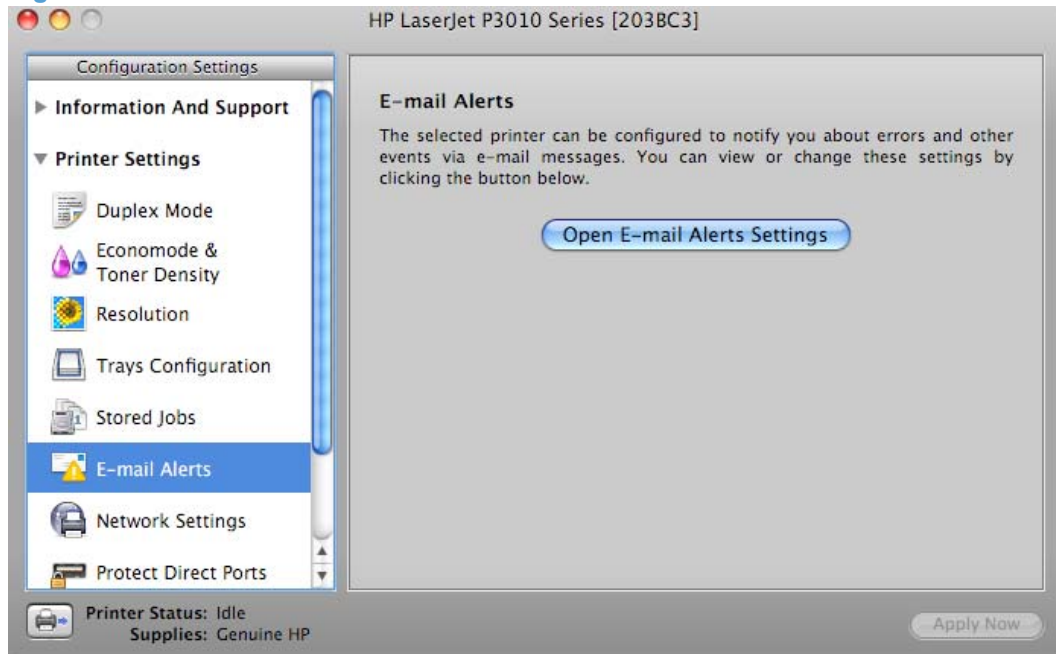

Click **Open E-mail Alerts Settings** to open the HP EWS. The HP EWS opens to the **Setup** screen on the **Alerts** tab, where you can set notifications.

Network Settings

Select **Network Settings** to open the **IP Settings** screen.

Figure 5-23 IPv4 Settings screen

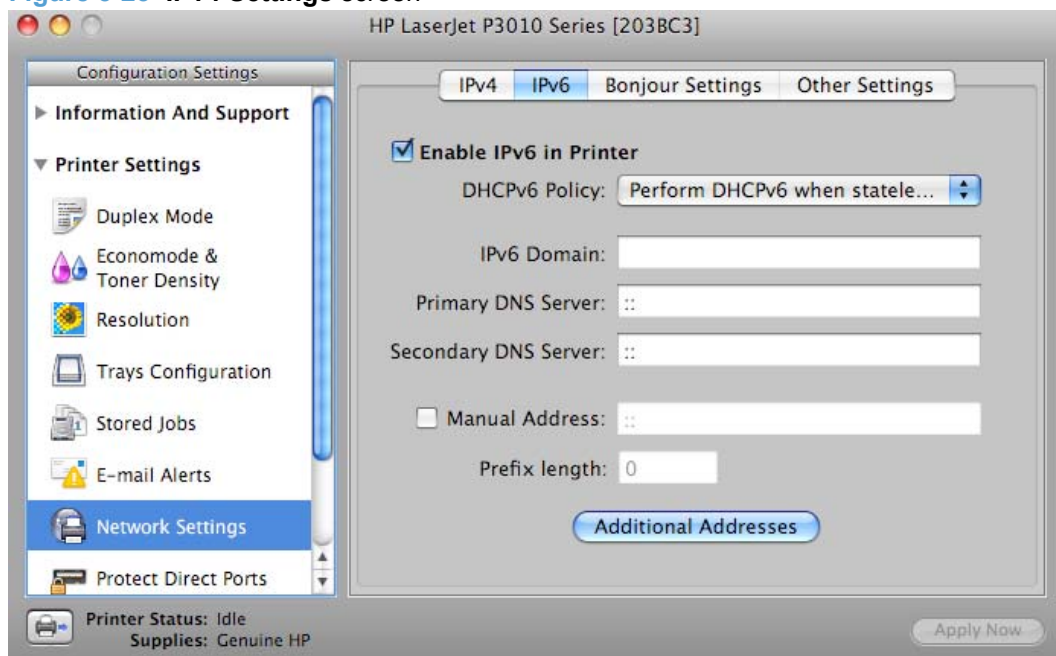

The **Network Settings** screen provides access to **IPv4**, **IPv6**, **Bonjour Settings**, and **Other Settings**.

- **DHCP**
- **BootP**
- **Manual**

You can also use this screen to modify the following settings:

- **Host Name**
- **IP Address**
- **Subnet Mask**
- **Default Gateway**

To save new settings, click **Apply Now**.

To view and change other network settings, click **Other Settings**.

If a user name and password have been set, you might need to obtain them from your IT administrator. For more information, see the *HP LaserJet P3010 Series Embedded Web Server User Guide*.

The HP EWS opens to the **Network Settings** screen.

To view and change the Bonjour network settings, click **Bonjour Settings**. Bonjour is enabled by default.

To disable Bonjour, click to clear the **Enable Bonjour** check box and then click **Apply Now**.

Select **Bonjour Settings** to open the **Bonjour Settings** screen. Bonjour is enabled by default.

The following options are available in the **The highest priority service** drop-down menu:

- **Port 9100** (default)
- **IPP**
- **LPD-RAW**
- **LPD-TEXT**
- **LPD-AUTO**
- **LPD-BINPS**

After you select a new setting, click **Apply Now** to save it.

Protect Direct Ports

Use this setting to disable printing over USB and parallel ports. JetDirect, embedded network connectivity, and third-party add-on cards, such as FireWire, will not be affected by this setting.

Figure 5-24 Protect Direct Ports screen

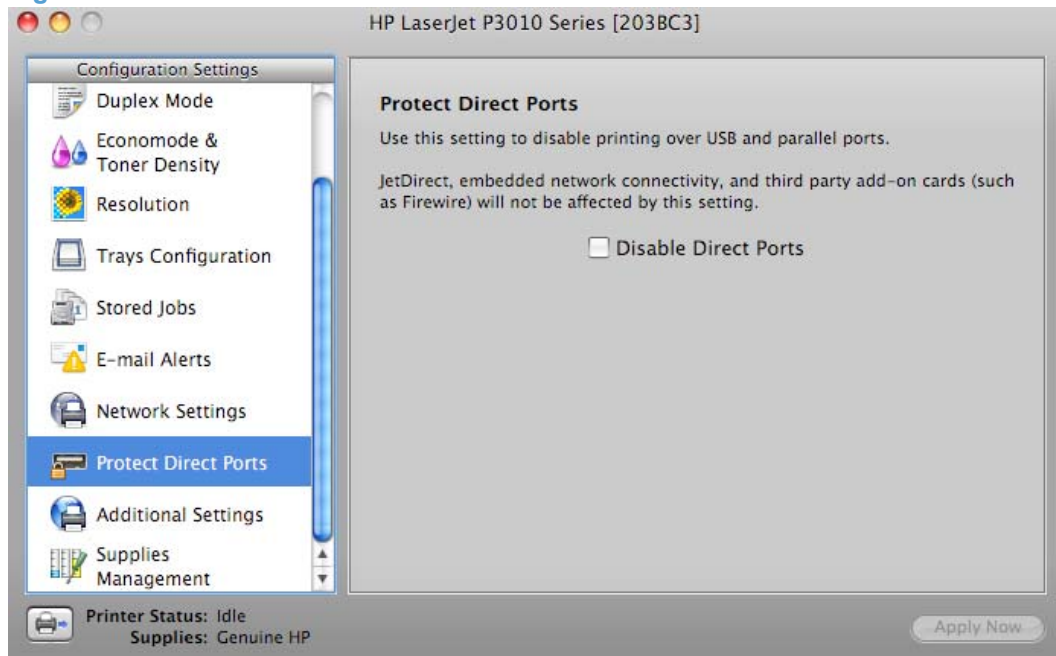

Click **Disable Direct Ports**

Additional Settings

Select **Additional Settings** to gain access to the HP EWS.

Figure 5-25 Additional Settings screen

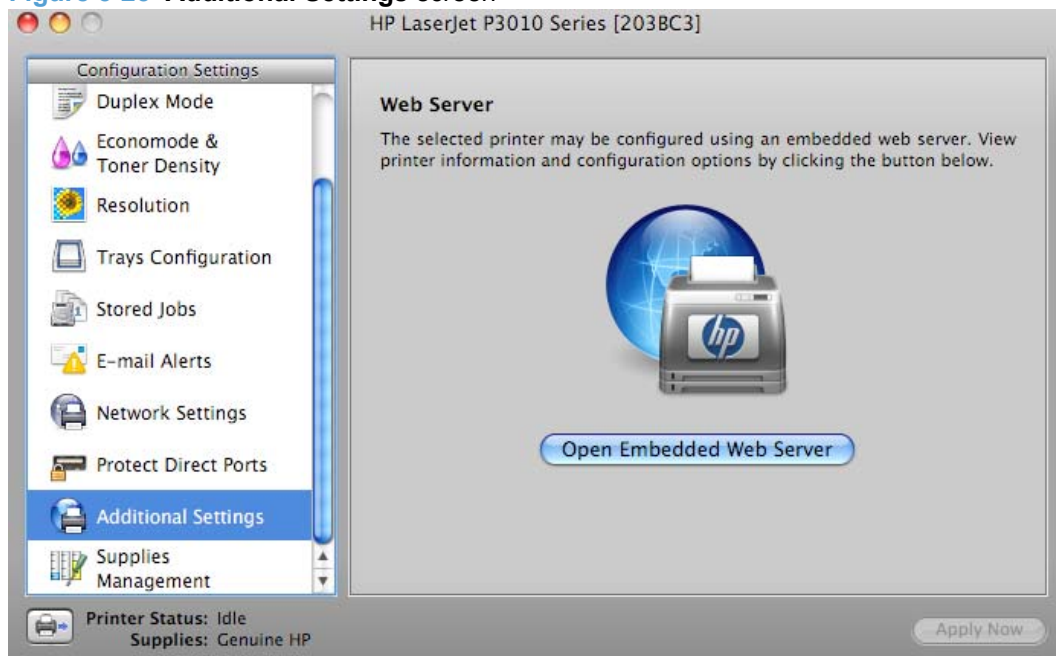

To open the HP EWS, click **Open Embedded Web Server**.

For information about HP EWS settings, consult the *HP LaserJet P3010 Series Embedded Web Server User Guide*.

Supplies Management

Click **Supplies Management** in the **Configuration Settings** menu to open the **Replace Supplies** screen.

Figure 5-26 Replace Supplies screen

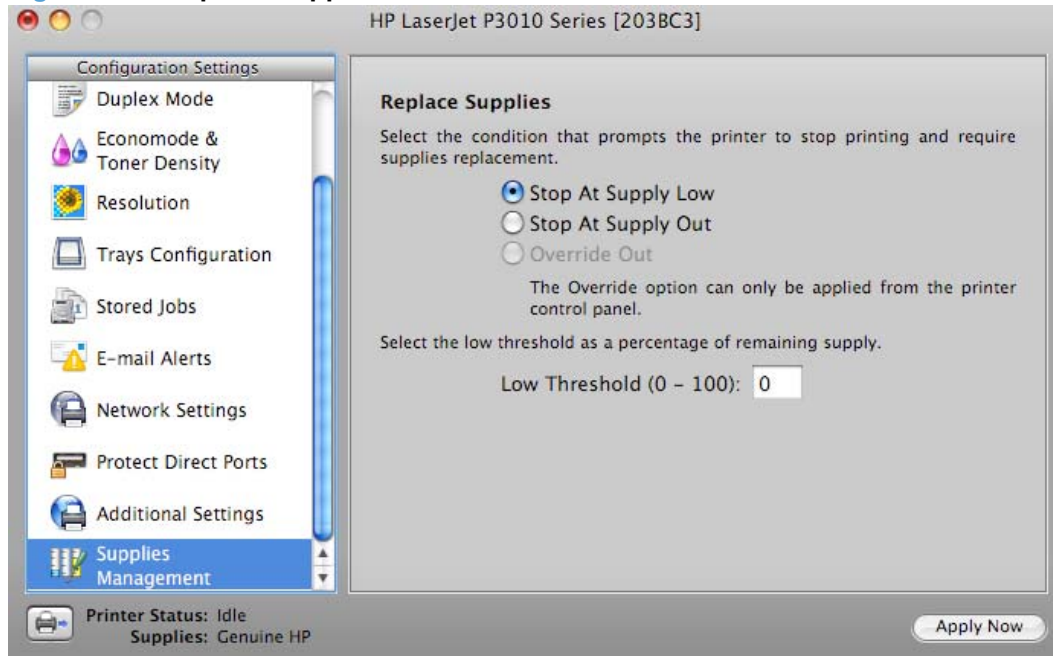

The settings on this screen prompt the product to stop printing at a certain threshold (a specific number of pages in the tray). By default, the **Stop At Supply Out** setting is selected.

To prompt the product to stop printing at a different threshold, select **Stop at Supply Low** and type a value in the **Low Threshold (0-100)** field. When the number of sheets in the tray reaches this value, the product stops printing.

You can also specify the product behavior when the color print cartridges run out. By default, the **Continue Printing in Black-Only Mode** is selected. To prompt the product to stop instead of continuing to print using the black cartridge, select **Stop**.

Click **Apply Now** to save the new settings.

Use features in the Macintosh printer driver

Create and use printing presets in Macintosh

Use printing presets to save the current printer driver settings for reuse.

Create a printing preset

1. On the **File** menu, click **Print**.
2. Select the driver.
3. Select the print settings.
4. In the **Presets** box, click **Save As...**, and type a name for the preset.
5. Click **OK**.

Use printing presets

1. On the **File** menu, click **Print**.
2. Select the driver.
3. In the **Presets** box, select the printing preset that you want to use.

 **NOTE:** To use printer-driver default settings, select **Standard**.

Resize documents or print on a custom paper size

You can scale a document to fit on a different size of paper.

1. On the **File** menu, click **Print**.
2. Open the **Paper Handling** menu.
3. In the area for **Destination Paper Size**, select **Scale to fit paper size**, and then select the size from the drop-down list.
4. If you want to use only paper that is smaller than the document, select **Scale down only**.

Print a cover page

You can print a separate cover page for your document that includes a message (such as “Confidential”).

1. On the **File** menu, click **Print**.
2. Select the driver.
3. Open the **Cover Page** menu, and then select whether to print the cover page **Before Document** or **After Document**.
4. In the **Cover Page Type** menu, select the message that you want to print on the cover page.

 **NOTE:** To print a blank cover page, select **Standard** as the **Cover Page Type**.

Use watermarks

A watermark is a notice, such as “Confidential,” that is printed in the background of each page of a document.

1. On the **File** menu, click **Print**.
2. Open the **Watermarks** menu.
3. Next to **Mode**, select the type of watermark to use. Select **Watermark** to print a semi-transparent message. Select **Overlay** to print a message that is not transparent.
4. Next to **Pages**, select whether to print the watermark on all pages or on the first page only.
5. Next to **Text**, select one of the standard messages, or select **Custom** and type a new message in the box.
6. Select options for the remaining settings.

Print multiple pages on one sheet of paper in Macintosh

You can print more than one page on a single sheet of paper. This feature provides a cost-effective way to print draft pages.

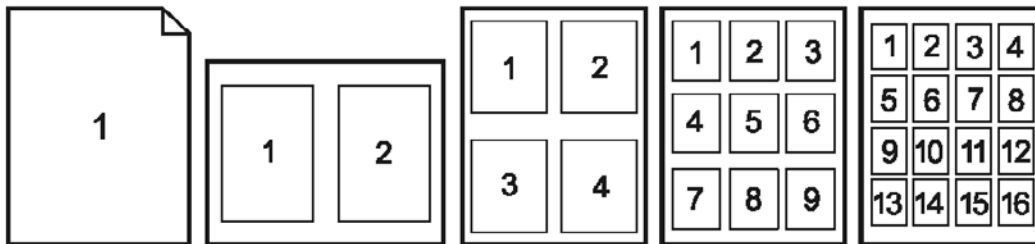

1. On the **File** menu, click **Print**.
2. Select the driver.
3. Open the **Layout** menu.
4. Next to **Pages per Sheet**, select the number of pages that you want to print on each sheet (1, 2, 4, 6, 9, or 16).
5. Next to **Layout Direction**, select the order and placement of the pages on the sheet.
6. Next to **Borders**, select the type of border to print around each page on the sheet.

Print on both sides of the page (duplex printing)

Use automatic duplex printing

1. Insert enough paper into one of the trays to accommodate the print job. If you are loading special paper such as letterhead, load it in one of the following ways:
 - For tray 1, load the letterhead paper face-up with the bottom edge feeding into the printer first.
 - For all other trays, load the letterhead paper face-down with the top edge at the back of the tray.
2. On the **File** menu, click **Print**.
3. Open the **Layout** menu.
4. Next to **Two-Sided**, select either **Long-Edge Binding** or **Short-Edge Binding**.
5. Click **Print**.

Print on both sides manually

1. Insert enough paper into one of the trays to accommodate the print job. If you are loading special paper such as letterhead, load it in one of the following ways:
 - For Tray 1, load the letterhead paper face-up with the top edge feeding into the printer first.
 - For all other trays, load the letterhead paper face-down with the top edge at the right of the tray.

△ **CAUTION:** To avoid jams, do not load paper that is heavier than 105 g/m² (28-lb bond).

2. On the **File** menu, click **Print**.
3. On the **Finishing** menu, Click the **Manual Duplex** tab.
4. Click the check box next to **Manual Duplex**.
5. Click **Print**. Follow the instructions in the pop-up window that appears on the computer screen before replacing the output stack in Tray 1 for printing the second half. Even pages are printed first.

📄 **NOTE:** You can optionally print a guide with a print job that shows the correct way to insert the stack into Tray 1.

6. Go to the printer, and remove any blank paper that is in Tray 1.
7. Insert the printed stack face-up with the top edge feeding into the printer first in Tray 1. You *must* print the second side from Tray 1.
8. If prompted, press the appropriate control-panel button to continue.

Store jobs

You can store jobs on the product so you can print them at any time. You can share stored jobs with other users, or you can make them private.

1. On the **File** menu, click **Print**.
2. Open the **Job Storage** menu.

3. In the **Job Storage Mode**: drop-down list, select the type of stored job.
4. For the **Stored Job**, **Private Job**, and **Private Stored Job** types of stored jobs, enter a name for the stored job in the box next to **Job Name**:

Select which option to use if another stored job already has that name.

- **Use Job Name + (1 - 99)** appends a unique number to the end of the job name.
 - **Replace Existing File** overwrites the existing stored job with the new one.
5. If you selected **Stored Job** or **Private Job** in step 3, type a 4-digit number in the box next to **PIN To Print (0000 - 9999)**. If other people attempt to print this job, the product prompts them to enter this PIN number.

Use the Services menu

If the product is connected to a network, use the **Services** menu to obtain product and supply-status information.

1. On the **File** menu, click **Print**.
2. Open the **Services** menu.
3. To open the HP EWS and perform a maintenance task, do the following:
 - a. Select **Device Maintenance**.
 - b. Select a task from the drop-down list.
 - c. Click **Launch**.
4. To go to various support Web sites for this device, do the following:
 - a. Select **Services on the Web**.
 - b. Select **Internet Services**, and select an option from the drop-down list.
 - c. Click **Go!**.

6 Engineering Details

Introduction

This chapter presents engineering detail for the following topics:

- [Remote firmware update](#)
- [Printing print-ready documents](#)
- [Media attributes](#)

Remote firmware update

The HP LaserJet P3010 Series product features remote firmware update (RFU) capability. The method for downloading remote firmware updates from the Web site is similar to that used to download the latest printing-system software and print drivers.

The process for remotely upgrading firmware involves three steps:

1. Determine the current level of firmware that is installed on the product.
2. Go to the HP Web site and download the latest firmware to the computer.
3. Download the new firmware to the product.

Determining the current level of firmware

To determine the current level of firmware, view the configuration page. To print a configuration page, follow these instructions.

Print a configuration page

1. Press the **menu** button  to open the menus.
2. Press the **up arrow** ▲ or the **down arrow** ▼ to scroll to **INFORMATION**, and then press **OK**.
3. Press the **up arrow** ▲ or the **down arrow** ▼ to scroll to **PRINT CONFIGURATION**.
4. Press **OK** to print the configuration page.

Downloading the new firmware from the HP Web site

The remote firmware update (.RFU) file and an associated readme file are packaged together as a self-extracting .EXE file. For detailed instructions about how to download the .EXE file, go to the following URL:

www.hp.com/go/ljp3010_firmware

The .EXE file consists of a readme file and the .RFU file.

 **NOTE:** For UNIX systems, the remote firmware update file is a .TAR file.

For Macintosh systems, the remote firmware update file is an .SIT, .DMG, or .ZIP file.

Downloading the new firmware to the product

For support information about downloading new firmware from the Web, go to:

www.hp.com/go/ljp3010_firmware

The product can receive a firmware update when the product is in a **READY** state. The product waits for all of the I/O channels to become idle before performing the update.

 **NOTE:** If the firmware update involves a change in the format of nonvolatile random-access memory (NVRAM), any menu settings that are changed from the default settings will return to default settings. The settings must be changed again if you want them to be different from the defaults. Examples of settings that are affected in this way are tray types, default symbol sets, and Web-access alerts.

The elapsed time for an update depends on the I/O transfer time, as well as the time that it takes for the product to reinitialize. The I/O transfer time depends on a number of things, including the speed of the host computer that is sending the update and the I/O method (parallel or network). The reinitialization time depends on the specific hardware configuration of the product, such as the number of EIO devices installed, the presence of external paper-handling devices, and the amount of memory that is installed.

Finally, any print jobs that are ahead of the RFU job in the queue are printed before the update is processed.

Use one of the methods described in this manual to update the product firmware.

Printer messages during the firmware update

The following table lists the causes and results of possible interruptions to the firmware update.

Table 6-1 Troubleshooting a firmware update

Cause	Result
The job was cancelled from the control panel.	No update has occurred.
A break in the I/O stream occurred during send (for example, the parallel cable was removed).	No update has occurred.
A power cycle occurred during the RECEIVING UPGRADE process.	No update has occurred.
A power cycle occurred during the PERFORMING UPGRADE process.	No update has occurred. Resend the update through a parallel port or USB connection.
A power cycle occurred during the INITIALIZING process.	The update has been completed.

Print jobs that are sent to the product while an update is in process do not interrupt the update.

All HP LaserJet products leave the factory with the most recent firmware version installed. If a remote firmware update fails in a Windows OS, the .RFU file must be resent. For more information, see [Table 6-3 Update messages on page 208](#).

If a remote firmware update fails in a Macintosh OS, contact support from an HP Customer Care Center.

The following table lists possible reasons for the failure of a remote firmware update and the corrective action required for each situation.

Table 6-2 Troubleshooting a firmware update failure

Reason for firmware update failure	Corrective action
The .RFU file is corrupted.	The product recognizes that the file is corrupted and rejects the update. Download the file again and send the new file to the product. Download the file from www.hp.com/go/cljP3010_firmware .
The wrong product is contained in the .RFU file.	The product recognizes the product mismatch and rejects the update. Download the correct file and send it to the product. Download the file from www.hp.com/go/cljP3010_firmware .
The upgrade was interrupted.	See Table 6-3 Update messages on page 208 .
A flash hardware failure occurred.	Although it is extremely unlikely, the product might have a hardware failure. Call technical support to address the problem (see the flyer that came with the product for a local telephone support list).

Three messages appear during a normal update process; a fourth (RESEND UPGRADE) appears only if the update process does not succeed.

Table 6-3 Update messages

Printer message	Explanation
RECEIVING UPGRADE	This message appears from the time the product recognizes the beginning of an .RFU update until the time the product has verified the validity and integrity of the .RFU update. NOTE: If the remote firmware update process is interrupted before the firmware is downloaded (while RECEIVING UPGRADE appears on the control-panel display), the firmware file must be sent again. No message appears on the product control panel to indicate that the update was interrupted.
PERFORMING UPGRADE	This message appears while the product is actually reprogramming the firmware. NOTE: If power is lost during the flash DIMM update (while PERFORMING UPGRADE appears on the control-panel display), the update is interrupted and the message RESEND UPGRADE appears on the control-panel display.
INITIALIZING	This message appears from the time the product has finished reprogramming the DIMM until the product reinitializes.
RESEND UPGRADE	This message appears (in English only) if the firmware update fails because the RFU process is interrupted. It can also occur if firmware for accessories (such as the duplex unit or an output device) fails to update. Perform another update by any means that is supported by the product, regardless of the connection (network, parallel, or USB).
RFU LOAD ERROR SEND RFU UPGRADE ON <X> PORT where X = Network or USB	This message appears (in English only) if the firmware update fails because the print-engine firmware is corrupted. NOTE: When this message appears, the firmware upgrade must be sent twice to upgrade all firmware components, even though the product returns to ready after the first upgrade.
DOWNLOAD FILE NOW SEND RFU UPGRADE MISMATCH BETWEEN PRODUCT AND FILE	The wrong firmware file was sent to the product. Send the correct firmware file.

 **NOTE:** To verify that the firmware update succeeded, print a new configuration page from the control panel and verify that the firmware date code on the configuration page has changed.

NOTE: If the product exhibits unexpected behavior after correcting a firmware update, turn the power off, and then back on.

Remote firmware update by using FTP through a browser

Complete the following steps to update the product firmware by using file transfer protocol (FTP) through a browser.

 **NOTE:** The following instructions can be used in Windows operating systems only.

1. Make note of the TCP/IP address on the EIO-Jetdirect page. The EIO-Jetdirect page is the second page of the configuration page printout. To print a configuration page, see [Determining the current level of firmware on page 206](#)
2. Open a browser window.
3. In the address line of the browser, type `ftp://<IPADDRESS>`, where <IPADDRESS> is the TCP/IP address of your product. For example, if the TCP/IP address is 192.168.0.90, type `FTP://192.168.0.90`
4. Locate the downloaded .RFU file for the product.
5. Drag and drop the .RFU file onto the **PORT1** icon or onto any open space in the browser window.

 **NOTE:** If the **PORT1** icon does not appear as a folder name, you might have to enable folder viewing for FTP sites in your Web browser. In Microsoft Internet Explorer, use the following procedure to enable the folder view.

- a. Select **Tools**, select **Internet Options**, and then select the **Advanced** tab.
 - b. Select the **Enable folder view for FTP sites**.
 - c. Click **OK** to save the setting.
 6. The download process begins and the firmware is updated on the product. This can take several minutes. Let the process finish without further interaction with the product or the computer. The messages described in the section [Printer messages during the firmware update on page 207](#) appear on the control panel.
-  **NOTE:** The product automatically turns off and then on again to activate the update; this can happen more than once. At the end of the update process, the **READY** message appears on the control panel. Do *not* turn off the product or interfere with the update until you see this message.
7. Print a configuration page and verify that the firmware revision number matches the revision of the current update.

Remote firmware update by using FTP on a direct network connection

If the HP LaserJet P3015 uses a direct network connection, use file transfer protocol (FTP) to update the firmware. Complete the following steps for your operating system.

Windows operating systems

1. Make note of the TCP/IP address on the Embedded Jetdirect page. The HP Embedded Jetdirect page is the second page of the configuration page printout. To print a configuration page, see [Determining the current level of firmware on page 206](#)
-  **NOTE:** Before connecting to the product, make sure that the product is not in Powersave mode. Also make sure that any error messages are cleared from the control-panel display.
2. Open a command window on the computer.
 3. Type `ftp <TCP/IP product ADDRESS>`. For example, if the TCP/IP address is 192.168.0.90, type `ftp 192.168.0.90`.
 4. Press **Enter** on the keyboard.

5. When prompted for the user name, press [Enter](#).
6. When prompted for the password, press [Enter](#).
7. Type `bin` at the command prompt.
8. Press [Enter](#). The message **200 Type set to I, Using binary mode to transfer files** appears in the command window.
9. Type `put <FILENAME>`, where `<FILENAME>` is the name of the .RFU file that was downloaded from the Web, including the path. For example, type `put C:\LJ\P3010FW.RFU`, and then press [Enter](#).

 **NOTE:** If the file name or path includes a space, you must enclose the file name or path in quotation marks. For example, type the following path:

```
put "c:\My Documents\LJ\P3010fw.rfu"
```

The following series of messages appears in the command window:

200 PORT command successful

150 Opening BINARY mode data connection

226 Ready

226 Processing Job

226 Transfer complete

After these messages appear, a message containing transfer-speed information appears.

10. The download process begins and the firmware is updated on the product. This can take several minutes. Let the process finish without further interaction with the product or the computer. The messages described in the section [Printer messages during the firmware update on page 207](#) appear on the control panel.

 **NOTE:** The product automatically turns off and then on again to activate the update; this can happen more than once. At the end of the update process, the **READY** message appears on the control panel. Do *not* turn off the product or interfere with the update until you see this message.

11. Print a configuration page and verify that the firmware revision number matches the revision of the current update.
12. At the command prompt, type `bye` to exit the FTP command.
13. At the command prompt, type `exit` to return to the Windows interface.

Macintosh operating systems

1. Make a note of the TCP/IP address on the EIO-Jetdirect page. The EIO-Jetdirect page is the second page of the configuration page printout. To print a configuration page, see [Determining the current level of firmware on page 206](#).
2. Open a Terminal window on the computer. You can find the Terminal program on the computer hard drive in the Applications/Utilities folder.
3. Type `FTP <TCP/IP product ADDRESS>` For example, if the TCP/IP address is 192.168.0.90, type `FTP 192.168.0.90`

4. Press **Enter** on the keyboard.
5. When prompted for a user name and password, press **Enter**.
6. Type `put <path>`, where `<path>` is the location where the .RFU file was downloaded from the Web, including the path. For example, type `put /username/desktop/P30105fw.rfu`, and then press **Enter**.

 **NOTE:** If the file name or path includes a space, you must enclose the file name or path in quotation marks. For example, type `put "/user name/desktop/P3010FW.RFU"`.

To ensure that the entire path to the .RFU file is placed in the `put` command, type `put` and a space, and then drag and drop the .RFU file onto the terminal window. The complete path to the file is automatically placed after the `put` command.

7. The download process begins and the firmware is updated on the product. This can take several minutes. Let the process finish without further interaction with the product or the computer. The messages described in the section [Printer messages during the firmware update on page 207](#) appear on the control panel.

 **NOTE:** The product automatically turns off and then on again to activate the update; this can happen more than once. At the end of the update process, the **READY** message appears on the control panel. Do *not* turn off the product or interfere with the update until you see this message.

8. Print a configuration page and verify that the firmware revision number matches the revision of the current update.

Remote firmware update through a local Windows port

If the product is connected through a local port (parallel), then you can send the .RFU file directly to the product by using a `COPY` command from a command prompt or an MS-DOS window. At the command prompt, perform the following steps for your operating system.

Windows 2000 Service Pack 3, Windows XP, Windows Server 2003, or Windows Server 2008

The .RFU file can be sent directly to the product by typing a `copy` command at a command prompt or in an MS-DOS window.

1. At a command prompt, type `copy /b <FILENAME> <PORTNAME>`, where `<FILENAME>` is the name of the .RFU file (including the path) and `<PORTNAME>` is the name of the appropriate printer port (such as LPT1). For example, type the following:

```
C:\>copy /b c:\P3010fw.rfu lpt1
```

 **NOTE:** If the file name or path includes a space, you must enclose the file name or path in quotation marks. For example, type `C:\>copy /b "c:\My Documents\P3010fw.rfu" lpt1`

2. Press **Enter** on the keyboard.
3. The download process begins and the firmware is updated on the product. This can take several minutes. Let the process finish without further interaction with the product or the computer. The messages described in the section [Printer messages during the firmware update on page 207](#) appear on the control panel.



-  **NOTE:** The product automatically turns off and then on again to activate the update; this can happen more than once. At the end of the update process, the **READY** message appears on the control panel. Do *not* turn off the product or interfere with the update until you see this message.
4. Print a configuration page and verify that the firmware revision number matches the revision of the current update.
 5. At the command prompt, type `exit` to close the command window.

Remote firmware update through a USB port

If the product is connected over a USB connection, follow these instructions:

1. From a command prompt or in an MS-DOS window, type `copy /b <FILENAME>\<COMPUTERNAME>\<SHARENAME>`, where `<FILENAME>` is the name of the .RFU file (including the path), `<COMPUTERNAME>` is the name of the computer from which the product is being shared, and `<SHARENAME>` is the product share name. For example, type the following:

```
copy /b P3010fw.rfu\\your_computer\lj3010
```

-  **NOTE:** If the file name or path includes a space, you must enclose the file name or path in quotation marks. For example, type `C:\>copy /b "c:\My Documents\P3010fw.rfu" \\your_computer\lj3010`
2. Press **Enter** on the keyboard. The messages described in the section [Printer messages during the firmware update on page 207](#) appear on the control panel. The message **1 file(s) copied** appears on the computer screen.
 3. The download process begins and the firmware is updated on the product. This can take several minutes. Let the process finish without further interaction with the product or the computer. The messages described in the section [Printer messages during the firmware update on page 207](#) appear on the control panel.
-  **NOTE:** The product automatically turns off and then on again to activate the update; this can happen more than once. At the end of the update process, the **READY** message appears on the control panel. Do *not* turn off the product or interfere with the update until you see this message.
4. Print a configuration page and verify that the firmware revision number matches the revision of the current update.

Remote firmware update through a Windows network

If the product is shared on a Windows network, follow these instructions:

1. From a command prompt or in an MS-DOS window, type `copy /b <FILENAME> \<COMPUTERNAME>\<SHARENAME>`, where <FILENAME> is the name of the .RFU file (including the path), <COMPUTERNAME> is the name of the computer from which the product is being shared, and <SHARENAME> is the product share name. For example, type the following:

```
C:\>copy /b c:\P3010fw.rfu \\your_server\your_computer
```

 **NOTE:** If the file name or path includes a space, you must enclose the file name or path in quotation marks. For example, type `C:\>copy /b "c:\My Documents\P3010fw.rfu" \\your_server\your_computer`

2. Press **Enter** on the keyboard. The messages described in the section [Printer messages during the firmware update on page 207](#) appear on the control panel. The message **1 file(s) copied** appears on the computer screen.
3. The download process begins and the firmware is updated on the product. This can take several minutes. Let the process finish without further interaction with the product or the computer. The messages described in the section [Printer messages during the firmware update on page 207](#) appear on the control panel.

 **NOTE:** The product automatically turns off and then on again to activate the update; this can happen more than once. At the end of the update process, the **READY** message appears on the control panel. Do *not* turn off the product or interfere with the update until you see this message.

4. Print a configuration page and verify that the firmware revision number matches the revision of the current update.

Remote firmware update for UNIX systems

For UNIX systems, any command method that delivers the .TAR file to the product is acceptable, including the following:

1. At the command prompt, type `cp /home/yourmachine/FILENAME /dev/parallel>`, where </home/yourmachine/FILENAME> is the location of the .TAR file.
2. The download process begins and the firmware is updated on the product. This can take several minutes. Let the process finish without further interaction with the product or the computer. The messages described in the section [Printer messages during the firmware update on page 207](#) appear on the control panel.

 **NOTE:** The product automatically turns off and then on again to activate the update; this can happen more than once. At the end of the update process, the **READY** message appears on the control panel. Do *not* turn off the product or interfere with the update until you see this message.

3. Print a configuration page and verify that the firmware revision number matches the revision of the current update.

Remote firmware update by using the LPR command

 **NOTE:** This remote firmware update method is for use in Windows 2000 Service Pack 3, Windows XP, Windows Server 2003, and Windows Server 2008.

Complete the following steps to update the firmware by using the LPR command.

1. From a command window, type the following:

```
lpr -P <IPADDRESS> -S <IPADDRESS> -o l <FILENAME>
```

OR

```
lpr -S <IPADDRESS> -Pbins <FILENAME>
```

where IPADDRESS can be either the TCP/IP address or the hostname of the product, and where FILENAME is the filename of the .RFU file.

 **NOTE:** The parameter (-o l) consists of a lowercase "O", not a zero, and a lowercase "L", not the numeral 1. This parameter sets the transport protocol to binary mode.

2. Press **Enter** on the keyboard. The messages described in the section [Printer messages during the firmware update on page 207](#) appear on the control panel.
3. The download process begins and the firmware is updated on the product. This can take several minutes. Let the process finish without further interaction with the product or the computer. The messages described in the section [Printer messages during the firmware update on page 207](#) appear on the control panel.

 **NOTE:** The product automatically turns off and then on again to activate the update; this can happen more than once. At the end of the update process, the **READY** message appears on the control panel. Do *not* turn off the product or interfere with the update until you see this message.

4. Print a configuration page and verify that the firmware revision number matches the revision of the current update.
5. Type `exit` at the command prompt to close the command window.

HP Easy Firmware Upgrade utility

Use the HP Easy Firmware Upgrade utility to send a firmware file to the HP LaserJet P3010 Series.

When a firmware file is downloaded from the HP Web site, the .ZIP file contains two files, the HP Easy Firmware Upgrade utility self-extracting firmware executable and the readme file that is applicable for the product and firmware revision you are downloading.

The HP Easy Firmware Upgrade utility uses the current print path, USB, or network connection to communicate with the device, and does not require the use of the Windows spooler. This utility is only available for Windows operating systems.

Follow these instructions to complete the firmware update.

 **NOTE:** In some circumstances, the update might require ten minutes or more to complete.

Do not power cycle the printer or the computer during this process or the printer may become unstable and or unusable.

1. Download the HP Easy Firmware Upgrade utility from the following Web site.

www.hp.com/go/ljp3010_firmware

2. Double-click and extract the downloaded file to your desktop.

- Print a configuration page from the device. Under the Device Information heading, note the datecode and version number. These should change after you have successfully completed the firmware update. To print a configuration page, see [Determining the current level of firmware on page 206](#).
- Verify that the printer is at a **Ready** state.
- On your computer, locate the HP Easy Firmware Upgrade utility file.
- Double-click the HP Easy Firmware Upgrade utility file. The following dialog box appears.

Figure 6-1 HP Easy Firmware Upgrade utility screen 1

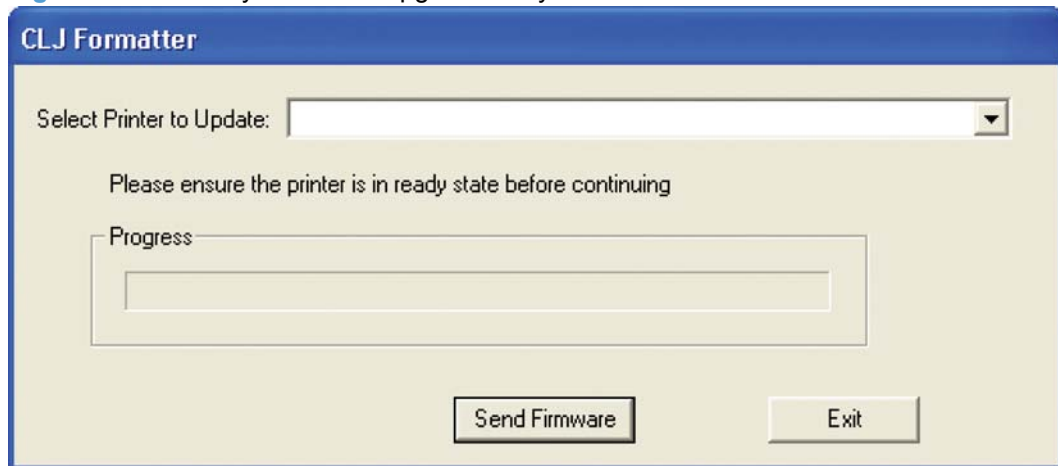

- Click the down arrow next to the **Select Printer to Update:** drop-down list and select the device you want to update.



 **NOTE:** If the device you want to upgrade is not in the list, you must install a printer-driver for the device and be able print to the device with the printer-driver before continuing.

Figure 6-2 HP Easy Firmware Upgrade utility screen 2

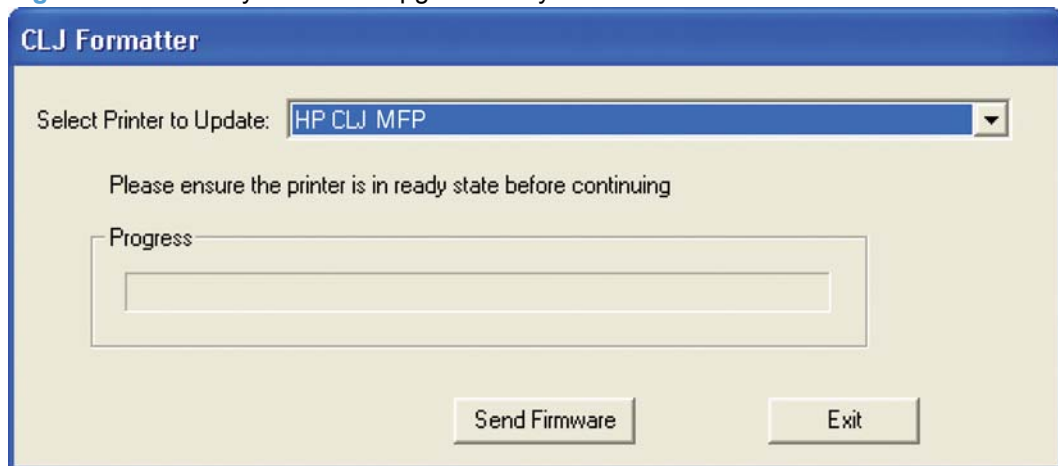

- Click the **Send Firmware** button to begin the update process.

 **CAUTION:** Interrupting the firmware upgrade process by turning the printer off and then turning it on again or by attempting to send a print job to the printer might cause the printer to go into an unrecoverable state.

- The progress bar gradually moves to the right during the firmware upgrade process.

 **NOTE:** The progress bar does not necessarily reflect the actual time needed for the firmware upgrade to complete.

Figure 6-3 HP Easy Firmware Upgrade utility progress screen



- The upgrade process is complete when an icon appears in the lower-right corner of the dialog box. A smiling icon appears when the utility completes successfully. A frowning icon appears when the utility completes unsuccessfully.

If the frowning icon appears, check to make sure the printer is on and at a **Ready** state. Verify that you can send print jobs to the printer, and then try again to perform the firmware update.

Figure 6-4 HP Easy Firmware Upgrade utility complete screen

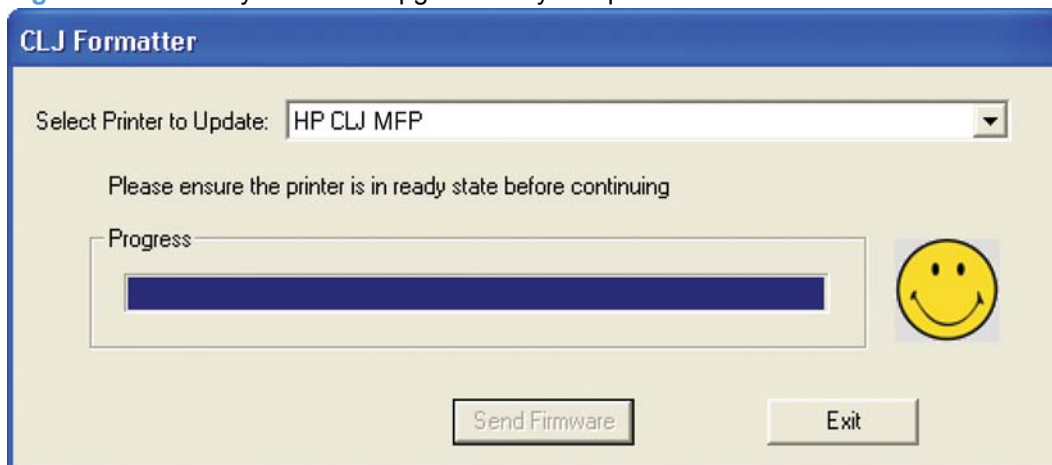

- Click **Exit** to close the dialog box.
- Turn the device off and then turn it on again.
- When the device is at a **Ready** state, print a Configuration page to verify that the version has changed.

Remote firmware update through HP Web Jetadmin

This procedure requires that you install HP Web Jetadmin V7.8 or later on the computer. Complete the following steps to update a single product through HP Web Jetadmin after downloading the .RFU file from the HP Web site.

1. Start HP Web Jetadmin.
2. Type the TCP/IP address or IP host name of the product in the **Quick Device Find** field, and then click **Go**. The product Status window opens.
3. Open the **Device Management** folder in the drop-down list in the Navigation panel. Navigate to the **Device Lists** folder.
4. Expand the **Device Lists** folder and select **All Devices**. Locate the product that you want to update in the list of products, and click to select it.
5. Locate the drop-down box for **Device Tools** in the upper-right corner of the window. Select **Update Printer Firmware** from the **choose action** list.
6. If the name of the .RFU file is not listed in the **All Available Images** dialog box, click **Browse** in the **Upload New Firmware Image** dialog box and navigate to the location of the .RFU file that you downloaded from the Web at the start of this procedure. If the filename is listed, select it.
7. Click **Upload** to move the .RFU file from your hard drive to the HP Web Jetadmin server.
8. Refresh the browser.
9. Select the .RFU file from the **Printer Firmware Update** drop-down menu.
10. Click **Update Firmware**. HP Web Jetadmin sends the selected .RFU file to the product.
11. The download process begins and the firmware is updated on the product. This can take several minutes. Let the process finish without further interaction with the product or the computer. The messages described in the section [Printer messages during the firmware update on page 207](#) appear on the control panel.

 **NOTE:** The product automatically turns off and then on again to activate the update; this can happen more than once. At the end of the update process, the **READY** message appears on the control panel. Do *not* turn off the product or interfere with the update until you see this message.

HP Web Jetadmin V7.8 and later can also be used to perform multiple or unattended installations. Complete the following steps for multiple or unattended installations.

1. Start HP Web Jetadmin.
2. Create a device group. A simple way to do this is to follow these steps:
 - a. Click **Device Management**, and then click **All Devices**.
 - or-
 - b. Shift-click to select products that you want to be included in the group, and then click **OK**.
 - or-
 - c. When prompted, type a name for the new device group, and then click **OK**.
3. To modify several products in a group, click the group name, and then click **Open**.

4. The drop-down menu for **Device Group Tools** appears on the right side of the window. Scroll if necessary to view it.
5. In the **Device Group Tools** drop-down box, select an action. Type the appropriate information. Click **Return to Device Group** when finished.

Printing print-ready documents

Several methods are available for printing documents independently of the original software program that was used to create the document. Normally, the document is printed by opening the original application and printing it to a file, or is printed by means of a distribution method such as internet downloading. The following print-ready file formats can be sent directly to the HP LaserJet P3010 Series product without first opening the original software program:

- HP LaserJet Printer Control Language (.PRN)
- Portable Document Format (.PDF)
- Postscript (.PS)
- Text (.TXT)

Use one of the following methods to send print-ready files to your product.

 **NOTE:** The examples that are used here are for printing .PDF documents. However, any print-ready file type can be substituted.

Print-ready file printing by using FTP through a browser

Complete the following steps to print print-ready files directly by using FTP through a browser.

 **NOTE:** The following instructions can be used on Windows or Macintosh operating systems.

1. Make note of the TCP/IP address on the Embedded Jetdirect page. The HP Embedded Jetdirect page is the second page of the configuration page printout. To print a configuration page, see [Determining the current level of firmware on page 206](#).
2. Open a browser window.
3. In the address line of the browser, type `ftp://<IPADDRESS>`. For example, if the TCP/IP address of your product is 192.168.0.90, type the following:

```
FTP:// 192.168.0.90
```

4. Locate the print-ready file for the product.
5. Drag and drop the print-ready file onto the **PORT1** icon in the browser window.

 **NOTE:** If the **PORT1** icon does not appear as a folder name, you might have to enable folder viewing for FTP sites in your Web browser. In Microsoft Internet Explorer, use the following procedure to enable the folder view.

1. Select **Tools**, then select **Internet Options**, and then select the **Advanced** tab.
2. Select the **Enable folder view for FTP sites**.
3. Click **OK** to save the setting.

Print-ready file printing by using FTP on a direct network connection

If the HP LaserJet P3010 Series uses a direct network connection, use file transfer protocol (FTP) to print a print-ready file. Complete the following steps for the operating system:

Windows operating systems

1. Take note of the TCP/IP address on the Embedded Jetdirect page. The HP Embedded Jetdirect page is the second page of the Configuration page printout. To print a configuration page, see [Determining the current level of firmware on page 206](#).
2. Open a command window on the computer.
3. Type `ftp <TCP/IP product ADDRESS>`. For example, if the TCP/IP address is 192.168.0.90, type the following:

```
ftp 192.168.0.90
```

4. Press **Enter** on the keyboard.
5. When prompted for the user name, press **Enter**.
6. When prompted for the password, press **Enter**.
7. Type `bin` at the command prompt.
8. Press **Enter**. The message **200 Types set to I, Using binary mode to transfer files** appears in the command window.
9. Type `put <FILENAME>`, where `<FILENAME>` is the name of the print-ready file to be printed, including the path. For example, type the following:

```
put C:\LJ\P3010FW.PDF
```

 **NOTE:** If the file name or path includes a space, you must enclose the file name or path in quotation marks. For example, type `put "c:\My Documents\LJ\P3010FW.PDF"`

The following series of messages appears in the command window:

200 PORT command successful

150 Opening BINARY mode data connection

226 Ready

226 Processing Job

10. Press **Enter** on the keyboard.
11. The print-ready file prints.
12. At the command prompt, type `bye` to exit the FTP command.
13. At the command prompt, type `exit` to return to the Windows interface.

Macintosh operating systems

1. Make note of the TCP/IP address on the Embedded Jetdirect page. The HP Embedded Jetdirect page is the second page of the configuration page printout. To print a configuration page, see [Determining the current level of firmware on page 206](#).

2. Open a Terminal window on your Macintosh. You can find the Terminal program on the computer in the following location:

System/Applications/Utilities/Terminal

Open the Finder, select **Applications**, and then click **Utilities**. Double-click to open the Terminal utility.

3. Type `FTP <TCP/IP product ADDRESS>`. For example, if the TCP/IP address is 192.168.0.90, type the following:

```
FTP 192.168.0.90
```

4. Press **Enter** on the keyboard.
5. When prompted for a user name and password, press **Enter**.
6. You can drag and drop the firmware file into the Terminal folder (System/Applications/Utilities/Terminal). Alternatively, you can type `put <path>`, where `<path>` is the location where the print-ready file was downloaded from the Web. For example, type the following:

```
put /username/desktop/P3010FW.PDF
```

 **NOTE:** If the file name or path includes a space, you must enclose the file name or path in quotation marks. For example, type `put "/user name/desktop/P3010FW.PDF"`

To ensure that the entire path to the print-ready file is placed in the `put` command, type `put` and a space, and then click and drag the print-ready file onto the terminal window. The complete path to the file is automatically placed after the `put` command.

7. Press **Enter**.
8. The download process begins and the firmware is updated on the product. This can take about five minutes. Let the process finish without further interaction with the product or computer.
9. The product automatically turns off and on again to activate the update.

Print-ready printing by using a local Windows port

To print directly by using a local Windows port, follow the instructions for your operating system.

Windows 2000 Service Pack 3, Windows XP, Windows Server 2003, Windows Server 2008, or Windows Vista

The print-ready file can be sent directly to the product by typing a `copy` command at a command prompt or in an MS-DOS window.

1. At a command prompt, type `copy /b <FILENAME> <PORTNAME>`, where `<FILENAME>` is the name of the print-ready file (including the path) and `<PORTNAME>` is the name of the appropriate printer port (such as LPT1). For example, type the following:

```
C:\>copy /b c:\P3010FW.PDF lpt1
```

2. Press **Enter** on the keyboard.

 **NOTE:** If the file name or path includes a space, you must enclose the file name or path in quotation marks. For example, type `C:\>copy /b "c:\My Documents\P3010FW.PDF"`. The message **PROCESSING JOB** appears on the control panel, and the job prints.

3. At the command prompt, type `exit` to close the command window.

Print-ready file printing in a Windows network

If the product is shared on a Windows network, complete the following steps.

1. From a command prompt or in an MS-DOS window, type `copy /b <FILENAME> \<COMPUTERNAME>\<SHARENAME>`, where `<FILENAME>` is the name of the print-ready file (including the path), `<COMPUTERNAME>` is the name of the computer from which the product is being shared, and `<SHARENAME>` is the product share name. For example, type the following:

```
C:\>copy /b c:\P3010FW.PDF \\your_server\sharename
```

 **NOTE:** If the file name or path includes a space, you must enclose the file name or path in quotation marks. For example, type `C:\>copy /b "c:\My Documents\P3010FW.PDF" \\your_server\sharename`

2. Press **Enter** on the keyboard. The message **PROCESSING JOB** appears on the control panel, and the job prints. The message **1 file(s) copied** appears on the computer screen.

Print-ready file printing in UNIX systems

For UNIX systems, any command method that delivers the print-ready file to the product is acceptable, including the following:

- At the command prompt, type `cp </home/yourmachine/FILENAME/ dev/parallel>`, where `</home/yourmachine/FILENAME>` is the location of the print-ready file.

Print-ready file printing by using the LPR command

 **NOTE:** This direct printing method is for use in Windows 2000, Windows XP, Windows Server 2003, Windows Server 2008, and Windows Vista.

Complete the following steps to print a print-ready file by using the LPR command.

1. Make note of the TCP/IP address on the Embedded Jetdirect page. The HP Embedded Jetdirect page is the second page of the configuration page printout. To print a configuration page, see [Determining the current level of firmware on page 206](#).

2. From a command window, type the following:

```
lpr -P <IPADDRESS> -S <IPADDRESS> -o l <FILENAME>
```

or

```
lpr -S <IPADDRESS> -Pbins <FILENAME>
```

where IPADDRESS can be either the TCP/IP address or the host name of the product, and where FILENAME is the file name of the print-ready file.

 **NOTE:** The parameter (-o l) consists of a lowercase "O", not a zero, and a lowercase "L", not the numeral 1. This parameter sets the transport protocol to binary mode.

3. The file prints, but no messages appear in the command prompt window.
4. Type `exit` at the command prompt to close the command window.

Media attributes

This section includes the following information about paper attributes:

- [Paper sources and destinations](#)
- [Paper-source commands](#)
- [Driver-supported paper sizes](#)
- [Driver-supported paper types](#)
- [Custom paper sizes](#)
- [Paper-type commands](#)

Paper sources and destinations

The following table indicates the standard and optional paper sources and destinations for the HP LaserJet P3010 Series product.

Table 6-4 HP LaserJet P3010 Series paper sources and destinations

Paper sources	100-sheet multipurpose tray (tray 1)	Standard
	250-sheet paper tray (tray 2)	Standard
	500-sheet paper tray (tray 3)	Standard on the HP LaserJet P3015x; option on all other HP LaserJet P3010 Series models
Paper destinations	50-sheet face-up output bin	Standard
	250-sheet face-down output bin	Standard

Paper-source commands

The PCL 6 Print driver attribute for paper source is `ubyte # MediaSource` or `ubyte_array "string" MediaSource`. See the following table for values of #. For example, `ubyte 4 MediaSource` is the command for Tray 2.

The PCL 5 print driver escape sequence for paper source is `Esc&l#H` (the "l" is a lowercase "L" rather than the numeral "1"). See the following table for values of #. For example, `Esc&l1H` is the command for Tray 2.

 **NOTE:** The HP LaserJet P3010 Series products support Tray 1, Tray 2, and Tray 3 only.

Table 6-5 Paper-source commands¹

Input source	PCL 5 <code>Esc&l#H</code>	PCL 6 <code>ubyte # MediaSource</code> ²	PCL 6 <code>ubyte_array "string" MediaSource</code>	PostScript <code>/MediaPosition # or null/ ManualFeed true or false</code>
Automatically select	NA	NA	NA	NA
Printer auto select	7	1	AUTOSELECT	null false

Table 6-5 Paper-source commands ¹ (continued)

Input source	PCL 5 Esc&l#H	PCL 6 ubyte # MediaSource ²	PCL 6 ubyte_array "string" MediaSource	PostScript /MediaPosition # or null/ ManualFeed true or false
Manual feed in tray 1	2	2	MANUALFEED	3 true
Tray 1 (100-sheet)	4	3	TRAY1	3 false
Tray 2 (250-sheet)	1	4	TRAY2	0 false
Tray 3 (500-sheet)	5	5	TRAY3	1 false
Tray 4 ¹	8	7	TRAY4	4 false
Tray 5 ¹	9	None	TRAY5	38 false
Tray 6 ¹	NA	None	TRAY6	39 false
Tray 7 ¹	NA	None	TRAY7	40 false
Tray 8 ¹	NA	None	TRAY8	41 false
Tray 9 ¹	NA	None	TRAY9	42 false
Tray # ³	20 to 39	8 to 55	TRAY# (# depends on the number of internal trays)	5 to 37 false
Envelope feeder ¹	6		ENVELOPETRAY	2 false

¹ Trays 4 through 9 and the envelope feeder are not options for the HP LaserJet P3010 Series products. The options are included in this table only to show what the Universal Print Driver (UPD) generally supports.

² For the string value, you must include the quotation marks around the variable. For example, `ubyte_array "TRAY2"`. `MediaSource` is the PCL 6 command for Tray 2.

³ Refers to optional trays.

Driver-supported paper sizes

The following table lists the features and attributes of various paper listed under the **Size Is**: drop-down menu on the **Paper** tab. The list order can vary, depending on the product and operating system. The list contains all of the following sizes, and might contain sizes from other drivers.

Table 6-6 Supported paper and print media sizes

Size and dimensions	Tray 1	Tray 2 and the optional 500-sheet trays	Duplexer (d, dn, and x models only)
Letter 216 x 279 mm (8.5 x 11 in)	X	X	X
Legal 216 x 356 mm (8.5 x 14 in)	X	X	X
Executive 184 x 267 mm (7.24 x 10.51 in)	X	X	

Table 6-6 Supported paper and print media sizes (continued)

Size and dimensions	Tray 1	Tray 2 and the optional 500-sheet trays	Duplexer (d, dn, and x models only)
Statement 140 x 216 mm (5.5 x 8.5 in)	X	X	
8.5 x 13 216 x 330 mm (8.5 x 13 in)	X	X	X
3 x 5 76 x 127 mm (3 x 5 in)	X		
4 x 6 102 x 152 mm (4 x 6 in)	X		
5 x 7 127 x 188 mm (5 x 7 in)	X	X	
5 x 8 127 x 203 mm (5 x 8 in)	X	X	
A4 210 x 297 mm (8.27 x 11.69 in)	X	X	X
A5 148 x 210 mm (5.83 x 8.27 in)	X	X	
A6 105 x 148 mm (4.1 x 5.8 in)	X	X	
B5 (JIS) 182 x 257 mm (7.2 x 10.1 in)	X	X	
B6 (JIS) 128 x 182 mm (5.0 x 7.2 in)	X	X	
10 x 15 cm 100 x 150 mm (3.9 x 5.9 in)	X		
16K 184 x 260 mm (7.2 x 10.2 in)	X	X	
16K 195 x 270 mm (7.7 x 10.6 in)	X	X	
16K 197 x 273 mm (7.8 x 10.8 in)	X	X	
Double Postcard (JIS) 148 x 200 mm (5.8 x 7.9 in)	X	X	

Table 6-6 Supported paper and print media sizes (continued)

Size and dimensions	Tray 1	Tray 2 and the optional 500-sheet trays	Duplexer (d, dn, and x models only)
Custom 76 x 127 mm to 216 x 356 mm (3.0 x 5.0 in to 8.5 x 14 in)	X		
Custom 105 x 148 mm to 216 x 356 mm (4.13 x 5.83 in to 8.5 x 14 in)		X	
Custom 210 x 280 mm to 216 x 356 mm (8.27 x 11 in to 8.5 x 14 in)			X
Envelope Commercial #10 105 x 241 mm (4.13 x 9.49 in)	X		
Envelope DL ISO 110 x 220 mm (4.33 x 8.66 in)	X		
Envelope C5 ISO 162 x 229 mm (6.93 x 9.84 in)	X		
Envelope B5 ISO 176 x 250 mm (6.7 x 9.8 in)	X		
Envelope Monarch #7-3/4 98 x 191 mm (3.9 x 7.5 in)	X		

Driver-supported paper types

The following table shows the paper types that the HP LaserJet P3010 Series print-drivers support.

Paper type (control panel)	Paper type (printer driver)	Tray 1	Tray 2 and optional 500-sheet tray	Automatic duplex printing
PLAIN	Plain	X	X	X
LIGHT 60–74 G/M2	Light 60-75g	X	X	X
BOND	Bond	X	X	X
RECYCLED	Recycled	X	X	X
MIDWEIGHT 96–110 G/M2	Midweight	X	X	X
HEAVY 111–130 G/M2	Heavy	X	X	X
EXTRA HEAVY 131–175 G/M2	Extra Heavy	X		
CARDSTOCK	Cardstock	X		
MONO TRANSPARENCY	Monochrome Laser Transparency	X		
LABELS	Labels	X		

Paper type (control panel)	Paper type (printer driver)	Tray 1	Tray 2 and optional 500-sheet tray	Automatic duplex printing
LETTERHEAD	Letterhead	X	X	X
ENVELOPE	Envelope	X		
PREPRINTED	Preprinted	X	X	X
PREPUNCHED	Prepunched	X	X	X
COLORED	Colored	X	X	X
ROUGH	Rough	X		

 **NOTE:** For a complete list of specific HP-brand paper that this product supports, go to www.hp.com/sbso/product/supplies.

Custom paper sizes

The following table shows custom paper sizes that are available for the HP LaserJet P3010 Series product.

Table 6-7 HP PCL 6 print driver custom paper sizes

Tray	Dimensions	Minimum	Maximum
Tray 1 (100-sheet multipurpose)	Width	98.4 mm (3.9 in)	216 mm (8.5 in)
	Length	148 mm (5.8 in)	356 mm (14.0 in)
Tray 2 (250-sheet)	Width	148 mm (5.83 in)	216 mm (8.5 in)
	Length	210 mm (8.27 in)	297 mm (11.69 in)
Tray 3 (500-sheet)	Width	148 mm (5.83 in)	216 mm (8.5 in)
	Length	210 mm (8.27 in)	356 mm (14.0 in)

Paper-type commands

The PCL 5 print driver escape sequence for paper type is "Esc&n#Wdpapertype", where "n#" is the number of characters in the paper type plus 1. For example, in the sequence "Esc&n6WdPlain", "Plain" has 5 letters plus 1, for a total of 6.

Table 6-8 paper-type commands

Esc&	n#	Wd	Paper type
Esc&	6	Wd	Plain
Esc&	11	Wd	Preprinted
Esc&	11	Wd	Letterhead
Esc&	13	Wd	Transparency ¹
Esc&	11	Wd	Prepunched
Esc&	7	Wd	Labels

Table 6-8 paper-type commands (continued)

Esc&	n#	Wd	Paper type
Esc&	5	Wd	Bond
Esc&	9	Wd	Recycled
Esc&	6	Wd	Color
Esc&	6	Wd	Light
Esc&	13	Wd	Interpaperte
Esc&	6	Wd	Heavy
Esc&	12	Wd	Extra Heavy
Esc&	11	Wd	Cardstock ²
Esc&	6	Wd	Rough
Esc&	7	Wd	Glossy
Esc&	12	Wd	Tough Paper
Esc&	9	Wd	Envelope

¹ You must spell out the word "Transparency" in the string, although it is abbreviated as TRANSPRNCY on the control panel.

² The correct command for cardstock is "Esc&n11WdCard Stock", with a space between the "d" and the "S", and with an uppercase "S".

Index

A

- accessibility features 6
- accessibility, documentation 28, 64, 65
- accessories
 - available 5
- accessories, automatic configuration 42
- Acrobat Reader
 - viewing documentation 23
- ADA (Americans with Disabilities Act) compliance 28, 64, 65
- Add Printer installation 69
- Add Printer Wizard, detailed install
 - existing port for a direct connection, using 71
 - print server connection 70
 - TCP/IP port for direction connection, creating 71
- Adobe Acrobat Reader
 - printing PDF files without 219
 - viewing documentation 23
- alerts, e-mail
 - HP Printer Utility 14, 169
 - Macintosh 196
- Americans with Disabilities Act (ADA) compliance 28, 64, 65
- autoconfiguration
 - driver 42
 - Enterprise AutoConfiguration, about 43
- autorun CD-ROM, Windows 37, 60

B

- Back button, Windows installation dialog boxes 97
- Basic Installation
 - choosing 37

- bidirectional communication
 - about 42
 - Enterprise AutoConfiguration 43
- bins, output
 - locating 8
- Bonjour Settings
 - HP Printer Utility 14, 169
- booklet printing
 - Booklet Layout settings 145
- both sides, printing on. *See* duplexing

C

- Cancel button, Windows installation dialog boxes 97
- cardstock, paper type commands 229
- cartridges
 - features 5
- cartridges, print
 - Macintosh status 204
- CD
 - Additional Options 68
 - Administrator CD 17
 - Administrator Documentation 62
 - Administrator Software 63
 - CD, about 24
 - Install 61
 - install Windows printing-system software from 60
 - languages, CD 18
 - Support 67
 - User CD 17
 - Windows installation from 24
- CD-ROM
 - directory structure, Macintosh 170

- installer, Windows printing-system software 36
- installing Macintosh printing-system software 173
- installing Windows printing-system software 69
- languages, Macintosh 170
- CHM files, viewing 23
- Citrix Terminal Server support 15
- command-line printing, Windows 219
- common installer, features 40
- components, software
 - Macintosh 16, 166
 - Windows 16
- configuration page
 - Macintosh 14, 169
- connectivity
 - bidirectional communication support 42
- constraint messages
 - print drivers 115
- continuous export 46
- control panel
 - locating 8
 - settings 34, 167
- copies
 - Quick Copy setting 152
- cover pages 201
- Custom Installation
 - choosing 37
- custom paper sizes
 - settings, Macintosh 201
- customer support
 - HP Printer Utility pages 14, 169

D

- default printer, setting 107

- density
 - settings 14, 169
 - device connection
 - installation xiv
 - device status
 - Macintosh Services tab 204
 - diagnostics
 - troubleshoot 156
 - dialog boxes, printing-system
 - software installation
 - Mac OS X 174
 - DIMMs
 - accessing 8
 - direct printing
 - FTP, Windows 219
 - local port, Windows 221
 - LPR 222
 - networks, Windows 222
 - UNIX 222
 - direct-connect installation 61
 - directory structure
 - Admin CD 18
 - directory structure, CD-ROM
 - Macintosh 170
 - disabling
 - driver features 45
 - disk space requirements
 - Macintosh 166
 - Windows 32
 - documentation
 - HP Driver Preconfiguration
 - Support Guide 26
 - HP Embedded Web Server User
 - Guide 25
 - HP Jetdirect Administrator's
 - Guide 26
 - install notes 28, 66
 - installing (Windows) 108
 - User Guide 27, 64, 65
 - viewing 23, 38
 - double-sided printing. *See*
 - duplexing
 - download
 - firmware 206
 - downloading
 - printing-system software 17
 - dpi, settings 14, 169
 - drivers
 - Add Printer installation 69
 - included 5
 - license agreement,
 - installation 82
 - Point and Print installation 74
 - drivers, install
 - license agreement 91
 - duplexing
 - Macintosh settings 14, 169
 - manual procedure 203
 - Tray 3 162
- E**
- e-mail alerts
 - Macintosh 196
 - e-mail alerts, Macintosh 14, 169
 - Embedded Web Server. *See* HP
 - EWS
 - Enterprise AutoConfiguration
 - (EAC)
 - about 43
 - envelopes, paper type
 - commands 229
 - error messages
 - e-mail alerts 14, 169
 - escape sequences
 - paper source 224
 - paper type 228
 - EWS. *See* HP EWS
 - exporting driver parameters 46
- F**
- FastRes 5
 - features 3, 5
 - File Upload, Macintosh 14, 169, 188
 - firmware
 - determine current level 206
 - download 206
 - FTP updates, Windows 209
 - HP Web Jetadmin
 - updates 217
 - LPR command updates 213
 - Macintosh updates 189, 210
 - messages during update 189
 - remote update,
 - Macintosh 189
 - troubleshoot updates 189
 - UNIX updates 213
 - update remotely 206
 - upload, HP Printer Utility 189
 - verifying installation 208
 - Windows network
 - updates 213
 - Windows, local port
 - update 211
- first page
 - use different paper 201
 fonts
 - included 5
 - install/remove external
 - fonts 159
 - Send True Type as Bitmap, print
 - drivers 118
 - True Type, print drivers 117
 - Upload Fonts, HP Printer
 - Utility 190
 - Upload Macintosh 14, 169
 - upload, Configuration Settings
 - menu 190
 - Windows 51, 53

FTP

 - direct printing, Windows 219
 - Windows firmware
 - updates 209
 Full Installation

 - choosing 37

H

 - heavy paper, paper type
 - commands 229
 - Help
 - print drivers 115
 - Help button, Windows installation
 - dialog boxes 97
 - HP Driver Deployment Utility 45
 - HP Driver Diagnostic Printer Check
 - Tool 48
 - HP Driver Installation Utility
 - (HPDIU)
 - device connection options xiv
 - for advanced installations 89
 - HP Driver Preconfiguration 44
 - HP Driver Preconfiguration Support
 - Guide 26
 - HP Easy Printer Care
 - description 13
 - downloading 13
 - supported browsers 13
 - supported operating
 - systems 13

- HP Embedded Web Server
 - HP Printer Utility, accessing from 199
- HP EWS
 - about 12, 49
 - documentation 25
- HP Jetdirect print server
 - Administrator's Guide 26
- HP OpenVMS 15
- HP PCL 5 Universal Print Driver
 - about 11
 - See also printer drivers
- HP PCL 6 Print Driver
 - features 111
 - settings 111
 - See also printer drivers
- HP PostScript Universal Print Driver
 - about 11
 - See also printer drivers
- HP Printer Utility for Macintosh
 - firmware update 189
- HP Printer Utility, Macintosh
 - about 14, 168, 186
 - access 186
 - Configuration Settings list 14
 - Device Information 188
 - E-mail Alerts 196
 - Embedded Web Server
 - access 199
 - features 168
 - File Upload 188
 - HP Support 191
 - Network Settings 197
 - open 14, 168
 - Supplies Management 200
 - Supplies Status 187
 - trays configuration 195
 - Upload Fonts 190
- HP Web Jetadmin
 - about 12, 50
 - Driver Preconfiguration Plugin 44
 - firmware updates 217
- HP-UX software 15
- HTML files, viewing 23

I

- Incompatible Print Settings messages. See constraint messages

- input trays. See trays
- Install Network Printer Wizard (INPW) 15
- install notes 28, 66
- installation
 - Add Printer 69
 - additional options 107
 - advanced 89
 - device connection xiv
 - dialog boxes, Mac OS X 174
 - HP Driver Installation Utility 89
 - Macintosh printing-system software 173
 - options 59
 - Point and Print 74
 - system requirements for Macintosh 166
 - system requirements for Windows 32, 58
 - troubleshooting
 - Macintosh 181
 - Windows CD-ROM 24
 - Windows printing-system software 58
- installers
 - common, features 40
 - Windows 36, 60
- interface ports, locating 9

J

- Jetadmin. See HP Web Jetadmin
- Jetdirect print server
 - See also HP Jetdirect print server
- Job Aids 7
- Job storage
 - Macintosh 196
- job storage
 - Macintosh settings 203
- job storage mode
 - personal job 152
 - proof and hold 151
- jobs
 - Macintosh settings 14, 169

L

- languages
 - CD 18
 - Macintosh CD-ROMs 170

- Linux
 - software 15
- local port command line printing, Windows 221
- localized CD-ROMs
 - Macintosh 170
- lockable features, drivers 45
- LPR commands
 - firmware updates 213
 - printing PDF files 222

M

- Macintosh driver settings
 - custom-size paper 201
 - Job Storage 203
 - Services tab 204
 - watermarks 202
- Macintosh operating systems
 - dialog boxes, Mac OS X printing-system software
 - installation 174
 - directory structure, CD-ROM 170
 - driver settings 168, 201
 - hardware requirements 166
 - HP Printer Utility 14, 168
 - installing printing-system software 173
 - localized software CDs 170
 - removing software 185
 - resize documents 201
 - software 168
 - software components 166
 - support 10
 - supported versions 13, 166
- Macintosh OS
 - Device Information 188
 - direct printing 219
 - e-mail alerts 196
 - File Upload command 188
 - firmware upgrades 189, 210
 - HP Printer Utility 186
 - Macintosh operating systems 210
 - network settings 197
 - setting up products with Mac OS X 183
 - stored jobs 196
 - Supplies Management 200
 - supplies status 187

- trays configuration 195
- troubleshooting setup 181
- Upload Fonts 190
- manuals. *See* documentation
- media
 - custom-size, Macintosh settings 201
 - first page 201
 - pages per sheet 202
- memory
 - included 168
 - installation requirements for Windows operating systems 32
 - Macintosh requirements 166
- messages
 - constraint, print drivers 115
 - e-mail alerts 14, 169
- Microsoft Windows. *See* Windows operating systems
- Microsoft Windows Cluster Server 8 support 15
- models, feature comparison 3
- mopy 163
- multiple pages per sheet 202
- multiple-original print. *See* mopy

N

- n-up printing 202
- networks
 - direct printing 222
 - firmware updates 213
 - HP Driver Preconfiguration 44
 - HP Driver Preconfiguration Support Guide 26
 - HP Jetdirect Administrator's Guide 26
 - Install Network Printer Wizard (INPW) 15
 - Macintosh settings 14, 169, 197
 - Point and Print installation 74
 - Windows printing-system software installation 81

O

- on/off button, locating 8
- operating systems
 - availability of software components 16

- supported 10, 11, 32, 33
- supported for Macintosh 13
- supported Macintosh versions 166
- ordering supplies 40, 67

P

- pages per sheet 202
- paper
 - Alternative Letterhead Mode 118
 - custom sizes 228, xi
 - custom-size, Macintosh settings 201
 - duplex binding settings, print drivers 145
 - first page 201
 - orientation 148
 - pages per sheet 202
 - settings, print drivers 127
 - source commands 224
 - sources and destinations 224
 - type commands 228
 - types and sizes supported 224
- parallel port direct-connect installation 61
- PCL files, command-line printing 219
- PDF files
 - command-line printing 219
 - LPR commands, printing 222
 - Macintosh, File Upload command 188
 - viewing 23
- personal job option
 - job storage 152
- PIN
 - Personal Job setting 152
 - PIN to print setting 153
- Point and Print installation, Windows printing-system software 74
- ports
 - supported 5
- ports, interface
 - locating 9
- PostScript Printer Description (PPD) files
 - included 168
- power button, locating 8
- PPDs, Macintosh
 - troubleshooting 185
- preconfiguration, driver 26, 44
- presets (Macintosh) 201
- print cartridges
 - features 5
 - Macintosh status 204
- print drivers
 - Allow Manual Duplexing setting, Device Settings tab 162
 - custom paper sizes 228
 - duplex unit, Device Settings tab 162
 - Envelopes setting, Printing Shortcuts tab 123
 - job name settings, Job Storage tab 154
 - job notification options, Job Storage tab 153
 - Job Storage Mode settings, Job Storage tab 151
 - job storage settings, Job Storage tab 154
 - Job Storage tab contents 149
 - paper source commands 224
 - paper supported 224
 - paper type commands 228
 - Personal Job setting, Job Storage tab 152
 - PIN to print setting, Job Storage tab 153
 - printer hard disk, Device Settings tab 162
 - Proof and Hold setting, Job Storage tab 151
 - Quick Copy setting, Job Storage tab 152
 - status message, Job Storage tab 151
 - Stored Job setting, Job Storage tab 152
 - Two-sided (Duplex) Printing setting, Printing Shortcuts tab 123
 - user name settings, Job Storage tab 153
- print job
 - delete stored job 155
 - hard disk, job storage 162

- job name settings 154
- job separator 163
- job storage 162
- Personal Job setting 152
- Proof and Hold setting 151
- Quick Copy setting 152
- release stored job 155
- Stored Job setting 152
- user name 153
- print on both sides
 - manually 143
 - Tray 3 162
- print-ready files
 - command-line printing 219
 - printing by FTP 219
 - printing by local Windows port 221
 - printing by Windows network 222
 - printing in UNIX systems 222
 - printing with LPR command 222
- printer driver
 - deployment 45
- printer drivers
 - About tab contents 164
 - accessory configuration 42
 - Advanced Printing Features settings, print drivers 117
 - Advanced tab content 116
 - Advanced tab contents 116
 - Alternative Letterhead Mode, Advanced tab 118
 - Automatic Configuration setting, Device Settings tab 149
 - Booklet Layout settings, Finishing tab 145
 - change Macintosh settings 168
 - check for most current in use 48
 - collation settings 163
 - continuous export feature 46
 - Copy Count settings, Advanced tab 117
 - device services, Services tab 157
 - Device Settings tab content 158
 - Document Options setting, Advanced tab 117
 - Document Options settings, Finishing tab 141
 - document preview image 133, 137, 147
 - Effects tab content 135
 - Enterprise
 - AutoConfiguration 43
 - Factory Defaults setting, Printing Shortcuts tab 124
 - Finishing tab contents 141
 - Flip Pages Up setting, Finishing tab 145
 - Font Substitution Table settings, Device Settings tab 159
 - Form to Tray Assignment setting, Device Settings tab 158
 - gain access to settings 113
 - General Everyday Printing setting, Printing Shortcuts tab 121
 - Graphic setting, Advanced tab 117
 - Help system 115
 - incompatible print settings messages 115
 - installable options, Device Settings tab 144
 - Internet Services options, Services tab 156
 - Job Separator setting, Device Settings tab 163
 - Layout Options setting, Advanced tab 119
 - lockable features 45
 - Macintosh 166
 - Macintosh settings 167, 201
 - mopier mode, Device Settings tab 163
 - Orientation settings, Finishing tab 148
 - Page Order settings, Finishing tab 146
 - Pages per Sheet setting, Finishing tab 145, 146
 - Paper Options settings, Paper/Quality tab 127
 - Paper source setting, Paper/Quality tab 129
 - Paper type setting, Paper/Quality tab 130
 - Paper/Output settings, Advanced tab 116
 - Paper/Quality tab contents 126
 - preconfiguration 44
 - preconfiguration support 26
 - presets (Macintosh) 201
 - Print on Both Sides settings, Finishing tab 142
 - Print Optimizations setting, Advanced tab 118
 - Printer Features setting, Advanced tab 118
 - Printing Preferences tab, driver access 113
 - Printing Shortcuts tab contents 120
 - Properties tab, driver access 114
 - Raster Compression feature, Advanced tab 118
 - Resizing Options settings, Effects tab 135
 - Send True Type as Bitmap setting, Advanced tab 118
 - Services tab content 156
 - settings 34
 - settings for Windows 35
 - supported for Windows 11, 33
 - tray 3, Device Settings tab 162
 - True Type font settings, Advanced tab 117
 - universal 11
 - Update Now 43
 - Update Now, bidirectional communication 149
 - version numbers for Windows 41
 - Watermarks settings, Effects tab 137
 - What's this? Help 115
 - See *also* HP PostScript Universal Print Driver; HP PCL

- 5 Universal Print Driver; HP PCL 6 Print Driver
- printer, setting default 107
- printing
 - direct in a Windows network 222
 - direct in UNIX 222
 - direct using FTP 219
 - direct using local Windows port 221
 - direct using LPR command 222
 - User Guide 28, 65, 66
- Printing Preferences
 - driver tabs 113
 - features 45
- printing-system software
 - installation 82
 - license agreement, installation 82
- printing-system software, install
 - license agreement 91
- priority, settings 34, 167
- processor speed 5
- product comparison 3
- proof and hold 151
- Properties driver tabs
 - gain access to 114
- ProRes 5
- PS emulation fonts 53
- PS files, command-line printing 219

Q

- Quick Reference Job Aids 7

R

- rear output bin
 - locating 8
- regional versions, CD-ROMs
 - Macintosh 170
- remote firmware updates
 - about 206
 - determine current firmware level 206
 - downloading 206
 - FTP, Windows 209
 - HP Web Jetadmin 217
 - LPR commands 213
 - Macintosh 189, 210

- messages 189
- troubleshoot 189
- UNIX 213
- verifying installation 208
- Windows network 213
- Windows, using local port 211
- removing Macintosh software 185
- resize documents
 - Macintosh 201
- resolution
 - features 5
 - settings 14, 169
- Resolution Enhancement technology (REt) 14, 169
- REt (Resolution Enhancement technology) 14, 169
- RFU. See remote firmware updates
- right-side panel, locating 8

S

- SAP printing 15
- scale documents
 - Macintosh 201
- screen-readable
 - documentation 28, 64, 65
- security features 6
- Services tab
 - Macintosh 204
- settings
 - continuous export 46
 - driver presets (Macintosh) 201
 - drivers, Macintosh 168
 - for Windows drivers 35
 - locking 45
 - priority 34, 167
- software
 - availability of components 16
 - HP Easy Printer Care 13
 - HP Embedded Web Server 12, 49
 - HP Printer Utility 14, 168
 - HP Web Jetadmin 12, 50
 - Macintosh 168
 - non-Windows and non-Macintosh operating systems 15
 - option install (Windows) 108
 - settings 34, 167

- supported operating systems 11, 32, 166
- uninstalling Macintosh 185
- Windows 11, 32
- software license agreement 82, 91
- Solaris software 15
- specifications
 - features 5
- status
 - HP Printer Utility, Macintosh 14, 168
 - Macintosh services tab 204
 - Macintosh supplies 187, 200
- storage, job
 - Macintosh 196
 - Macintosh settings 14, 169, 203
- supplies
 - Macintosh status 187, 200
 - ordering 40, 67
 - status, viewing with HP Printer Utility 14, 168
- support
 - HP Printer Utility pages 14, 169
 - Online Support screen 29
- Support tab, HP Printer Utility 191
- supported
 - operating systems 10
 - utilities for Macintosh 14
- system requirements
 - Windows 32

T

- TCP/IP port creation 71
- text files, command-line printing 219
- toner
 - density setting 14, 169
- top output bin
 - locating 8
- transparencies, paper type commands 229
- trays
 - Alternative Letterhead Mode 118
 - autoconfiguration 42
 - double-sided printing 203

- duplex unit 162
- included 224
- locating 8
- Macintosh configuration 195
- Macintosh settings 14, 169
- paper source commands 224
- paper type commands 228
- specify paper size 158
- tray 3 162
- troubleshoot
 - firmware upgrades 189
- troubleshooting
 - diagnostics 156
 - HP driver Diagnostic Printer
 - Check Tool 48
 - Macintosh setup 181
- Tru64 UNIX printing 15
- two-sided printing. *See* duplexing
- TXT files, command-line
 - printing 219

U

- uninstall
 - Macintosh software 185
 - products 110
- universal print drivers 11
 - See also* HP PCL 5 Universal Print Driver; HP PostScript Universal Print Driver
- UNIX operating systems
 - software 15
- UNIX OS
 - direct printing 222
 - print-ready printing 222
 - remote firmware update 213
- Update Now feature 43
- updating firmware remotely. *See* remote firmware update
- Upload fonts
 - Configuration Settings
 - menu 190
- USB direct-connect
 - installation 61
- USB port
 - supported 5
- User Guide 27, 64, 65

V

- version numbers, Windows
 - drivers 41

W

- watermarks
 - settings 137
- Web Jetadmin. *See* HP Web Jetadmin
- Web sites
 - Citrix Terminal server
 - support 15
 - downloading software 17
 - firmware download 206
 - HP Driver Diagnostic Printer
 - Check Tool 48
 - HP OpenVMS 15
 - Internet Services options,
 - Services tab 156
 - SAP printing 15
 - support links 39, 67
 - Tru64 UNIX printing 15
 - universal print drivers 11
- Windows operating systems
 - Add Printer installation 69
 - CD for 24
 - CD-ROM, print system 36, 60
 - default printer, setting 107
 - documentation 23
 - driver settings 35
 - driver versions 41
 - drivers supported 11
 - fonts supported 51
 - HP PCL 6 Print Driver
 - features 111
 - installation options 59
 - installation overview 60
 - installing printing-system 58
 - Microsoft Windows Cluster
 - Server 8 support 15
 - PS emulation fonts
 - supported 53
 - support 10
 - supported 58
 - supported versions 11, 32
 - system requirements 32, 58
 - universal print drivers 11
- Windows OS
 - direct printing, FTP 219
 - direct printing, local port 221
 - direct printing, networks 222
 - LPR commands 222
 - Point and Print installation 74
 - remote firmware update 211

